

# ELECTROBOMBA CENTRÍFUGA

Modelo: **SAP**  
0.5-2.5HP



- Sistemas Hidroneumáticos
- Bombeo a tinacos
- Riegos domésticos

Todos los modelos incluyen anillo de desgaste reemplazable

## SUCCIÓN

1-1/4"(3.18cm) a 2"(5.08cm) NPT Horizontal

## DESCARGA

1"(2.54cm) a 1-1/2"(3.81cm) NPT **4 POSICIONES**

## CUERPO

Hierro Gris A.S.T.M. A-48, Clase 30.

## BASE

Acero calibre 10

## EJE

Acero Inoxidable 304

## IMPULSOR

**Material:** Noryl<sup>®</sup>

**Inserto:** Bronce

Noryl<sup>®</sup> Es una marca registrada de General Electric Co.

## SELLO

**Diseño:** tipo mecánico lubricado por agua.

**Material:** Cerámica parte estacionaria, anillo de carbón y sello de exclusión parte rotatoria. Elastómero de Buna-N. Resorte de acero inoxidable.

## MOTOR

Se ensamblan a motores monofásicos y trifásicos de calidad reconocida (1 y 3 fases)

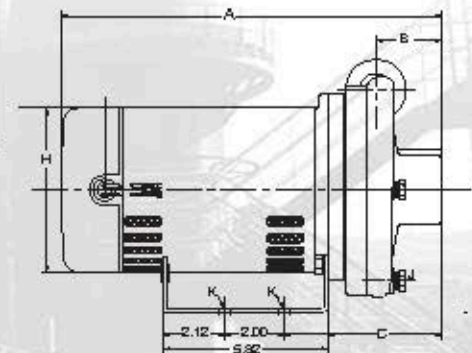
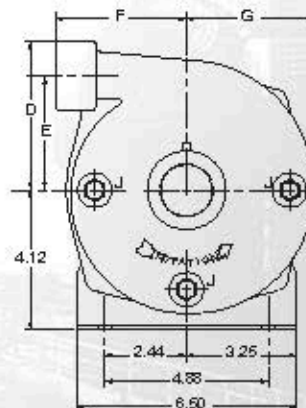

DIMENSIONES EN PULGADAS

HP	NPT Succ.	NPT Desc.	A (1 Fase)	A (3 Fases)	B	C	D	E	F	G	H	NPT J	K
1/2	1-1/4	1	11-21/32	13-3/8	2-1/16	5-9/16	4-3/4	3-7/16	3-7/8	3-15/16	5-5/8	1/4	3/8 Dia.
3/4	1-1/4	1	11-25/32	13-3/8	2-1/16	5-9/16	4-3/4	3-7/16	3-7/8	3-15/16	5-5/8	1/4	3/8 Dia.
1	1-1/4	1	11-25/32	13-7/8	2-1/16	5-9/16	4-3/4	3-7/16	3-7/8	3-15/16	5-5/8	1/4	3/8 Dia.
1-1/2	1-1/4	1	13-39/64	14-3/8	2-1/16	5-9/16	4-3/4	3-7/8	3-7/8	3-15/16	5-5/8	1/4	3/8 Dia.
2	1-1/2	1-1/4	16-3/4	16-15/16	2-13/16	6-5/16	4-27/32	4-5/8	4-5/8	4	6-7/8	1/4	3/8 Dia.
2-1/2	2	1-1/2	17-3/4	17-1/4	2-13/16	6-5/16	4-27/32	4-5/8	4-5/8	4	6-7/8	1/4	3/8 Dia.

INFORMACIÓN ELÉCTRICA							
Num. Catalogo	HP	Medida tubería roscada		Voltage de motor	Fases	Max. Amp. de carga	Peso Aprox. Lbs. / Kg
		Succ.	Desc.				
SAP50	½	1-1/4"	1"	115/230	1	8.8/4.4	39 / 17.6
SAP 75	¾	1-1/4"	1"	115/230	1	12.2/6.1	42 / 19.0
SAP100	1	1-1/4"	1"	115/230	1	14.8/7.4	37 / 16.7
SAP100-3		1-1/4"	1"	208-230/460	3	3.6/1.8	45 / 20.4
SAP 150	1-½	1-1/4"	1"	115/230	1	19.2/9.6	49 / 22.2
SAP 150-3		1-1/4"	1"	208-230/460	3	4.7/2.35	49 / 22.2
SAP 200	2	1-1/2"	1-1/4"	230	1	12.0	69 / 31.2
SAP200-3		1-1/2"	1-1/4"	208-230/460	3	6.8/3.4	69 / 31.2
SAP250	2-½	2"	1-1/2"	230	1	12.0	74 / 33.5
SAP250-3		2"	1-1/2"	208-230/460	3	8.5/4.25	74 / 33.5

Noryl® es una marca registrada de General Electric Co.  
Las especificaciones estan sujetas a cambios.

RENDIMIENTO DE LA BOMBA (capacidad en galones por minuto)							
HP	PRESION DESCARGA		ALTURA DINAMICA DE SUCCION				
	PSI	PIES	5'	10'	15'	20'	25'
		ALTURA					
½	10	23.1	-	34	32	29	26
	20	46.2	25	21	18	15	11
	30	69.3	10	-	-	-	-
¾	10	23.1	-	-	42	339	37
	20	46.2	35	32	30	28	26
	30	69.3	24	22	19	15	10
1	20	46.2	48	46	45	43	40
	30	69.3	38	35	31	28	25
	40	92.4	23	20	15	-	-
1-½	20	46.2	62	60	58	55	52
	30	69.3	50	48	44	40	37
	40	92.4	37	32	29	22	-
2	20	46.2	71	68	66	62	60
	30	69.3	60	57	52	59	45
	40	92.4	45	40	36	31	24
	50	115.5	22	15	-	-	-
2-½	20	46.2	81	79	76	74	71
	30	69.3	69	67	63	60	56
	40	92.4	56	51	47	44	38
	50	115.5	33	30	22	15	-

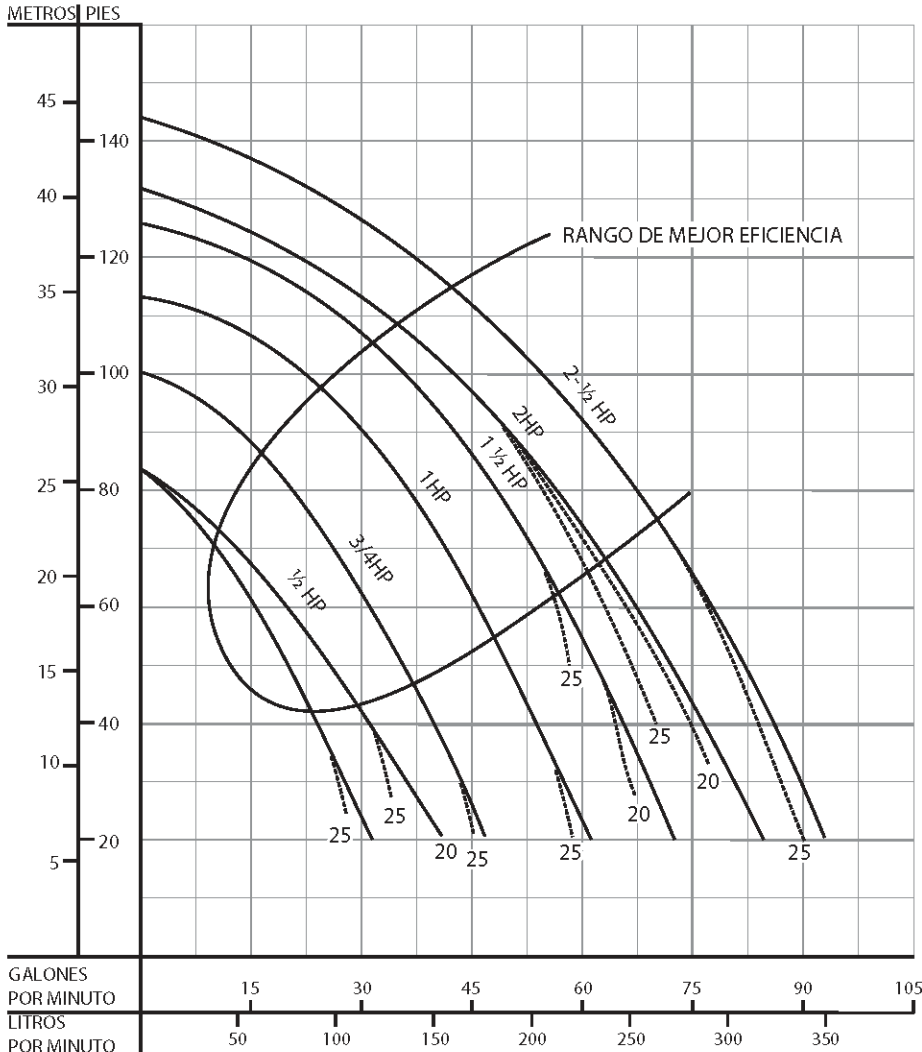

www.atb.com.mx  
 Email: ventas@atb.com.mx  
 Tel: 81-84797931