

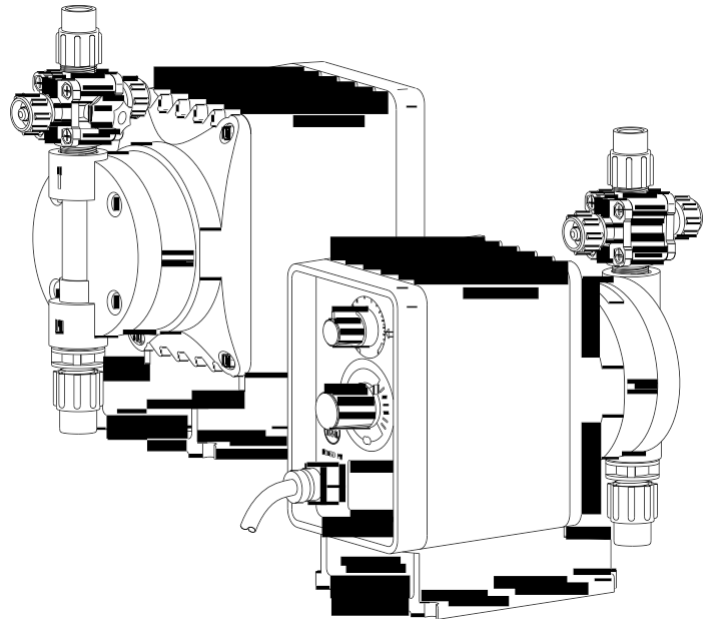

Configuration Data

Model **P14 1 - 358SI**

Electronic Metering Pumps



Manual Control

Speed (stroking frequency) fixed and stroke length manually adjustable.

- P02 --- 0.20 GPH (0.79 l/h) --- 150 psi (10.3 Bar)
- P03 --- 0.42 GPH (1.6 l/h) --- 110 psi (7.6 Bar)
- P04 --- 0.58 GPH (2.2 l/h) --- 250 psi (17.3 Bar)
- P05 --- 1.00 GPH (3.8 l/h) --- 110 psi (7.6 Bar)
- P06 --- 2.00 GPH (7.6 l/h) --- 50 psi (3.5 Bar)
- P08 --- 3.20 GPH (12.1 l/h) --- 22 psi (1.5 Bar)

Dual Manual Control

Speed (stroking frequency) and stroke length manually adjustable.

- P12 --- 0.20 GPH (0.79 l/h) --- 150 psi (10.3 Bar)
- P13 --- 0.42 GPH (1.6 l/h) --- 110 psi (7.6 Bar)
- P14 --- 0.58 GPH (2.2 l/h) --- 250 psi (17.3 Bar)
- P15 --- 1.00 GPH (3.8 l/h) --- 110 psi (7.6 Bar)
- P16 --- 2.00 GPH (7.6 l/h) --- 50 psi (3.5 Bar)
- P18 --- 3.20 GPH (12.1 l/h) --- 22 psi (1.5 Bar)

Instrument Responsive / Manual

Manual adjustment features of Series P1 plus switch conversion to external control for automatic systems.

- P74 --- 0.58 GPH (2.2 l/h) --- 250 psi (17.3 Bar)
- P75 --- 1.00 GPH (3.8 l/h) --- 110 psi (7.6 Bar)
- P76 --- 2.00 GPH (7.6 l/h) --- 50 psi (3.5 Bar)
- P78 --- 3.20 GPH (12.1 l/h) --- 22 psi (1.5 Bar)

Voltage Code

- 1 ----- 120 VAC US Plug
- 2 ----- 240 VAC US Plug
- 3 ----- 220-240 VAC DIN Plug
- 5 ----- 240-250 VAC, UK Plug
- 6 ----- 240-250 VAC, Aust./NZ Plug
- 7 ----- 220 VAC, Swiss Plug

Liquid End

See next page for complete liquid end specifications and selection.



Dimensions

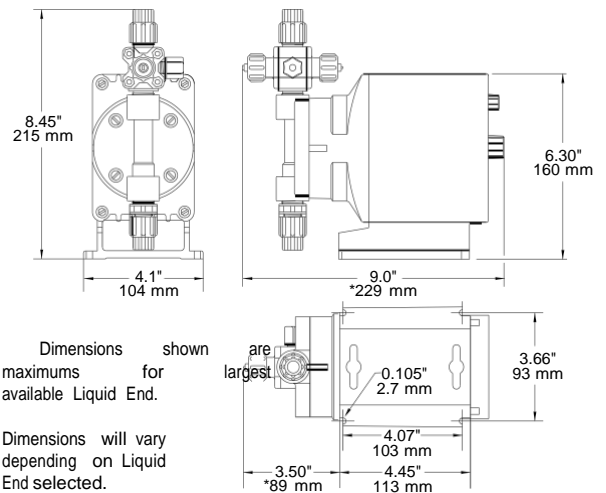

Specifications

Series	Strokes Per Minute (Adjustable)		Stroke Length (Adjustable) Recommended Minimum	Average Input Power @ Max Speed	Shipping Weight
	Min	Max			
P02, P03	fixed - 60		30%	22 watts	7.6 lbs (3.5 kg)
P04, P05	fixed - 100		20%		
P06, P08	.6	60	30%		
P12, P13	1	100	20%		
P14, P74	1	100	20%		
P15, P75 P16, P76 P18, P78	1	100	20%		

LMI
MILTON ROY

www.atb.com.mx



Configuration Data & Materials of Construction

Drive Assembly	Liquid End No.	Size Code	Head & Fittings	Materials of Construction			Accessory	Tubing & Connections	
				Balls	Liquifram™	Check Valve		Discharge	Suction
P02	458SI†	0.5	PVC / PVC	Ceramic	Fluorofilm™	PVDF / Polyprel®	4FV	PE .250" O.D.	
	450SI†	0.5	Acrylic / PVC	Ceramic	Fluorofilm™	PVDF / Polyprel®	4FV	PE .250" O.D.	
P04	450FI†	0.5	Acrylic / PVC	PTFE	Fluorofilm™	PVDF / Polyprel®	4FV	PE .250" O.D.	
P12	358SI†	0.5	PVC / PVC	Ceramic	Fluorofilm™	PVDF / Polyprel®	4FV	PE .250" O.D.	
P14	353SI†	0.5	PVDF / PVDF	Ceramic	Fluorofilm™	PVDF / PTFE	4FV	PE .250" O.D.	
P74	352SI†	0.5	PVDF / PVDF	Ceramic	Fluorofilm™	PVDF / Polyprel®	4FV	PE .250" O.D.	
	156HV	0.5	Acrylic / PP	316 S.S.	Fluorofilm™	Hypalon®		PE .5" O.D. Vinyl .938" O.D.	
	155HV	0.5	Polypropylene	316 S.S.	Fluorofilm™	PTFE		PE .5" O.D. Vinyl .938" O.D.	
	257	0.5	316 S.S.	316 S.S.	Fluorofilm™	316 S.S.		Pipe 1/4" NPT M	
P03	498SI†	0.9	PVC / PVC	Ceramic	Fluorofilm™	PVDF / Polyprel®	4FV	PE .375" O.D.	
P05	490SI†	0.9	Acrylic / PVC	Ceramic	Fluorofilm™	PVDF / Polyprel®	4FV	PE .375" O.D.	
P13	490FI†	0.9	Acrylic / PVC	PTFE	Fluorofilm™	PVDF / Polyprel®	4FV	PE .375" O.D.	
P15	398SI†	0.9	PVC / PVC	Ceramic	Fluorofilm™	PVDF / Polyprel®	4FV	PE .375" O.D.	
P75	393SI†	0.9	PVDF / PVDF	Ceramic	Fluorofilm™	PVDF / PTFE	4FV	PE .375" O.D.	
	392SI†	0.9	PVDF / PVDF	Ceramic	Fluorofilm™	PVDF / Polyprel®	4FV	PE .375" O.D.	
	86HV	0.9	Acrylic / PP	316 S.S.	Fluorofilm™	Hypalon®		PE .5" O.D. Vinyl .938" O.D.	
	85HV	0.9	Polypropylene	316 S.S.	Fluorofilm™	PTFE		PE .5" O.D. Vinyl .938" O.D.	
	297	0.9	316 S.S.	316 S.S.	Fluorofilm™	316 S.S.		Pipe 1/4" NPT M	
P06	468SI†	1.8	PVC / PVC	Ceramic	Fluorofilm™	PVDF / Polyprel®	4FV	PE .375" O.D.	
P08	460SI†	1.8	Acrylic / PVC	Ceramic	Fluorofilm™	PVDF / Polyprel®	4FV	PE .375" O.D.	
P16	460FI†	1.8	Acrylic / PVC	PTFE	Fluorofilm™	PVDF / Polyprel®	4FV	PE .375" O.D.	
P18	368SI†	1.8	PVC / PVC	Ceramic	Fluorofilm™	PVDF / Polyprel®	4FV	PE .375" O.D.	
P76	363SI†	1.8	PVDF / PVDF	Ceramic	Fluorofilm™	PVDF / PTFE	4FV	PE .375" O.D.	
P78	362SI†	1.8	PVDF / PVDF	Ceramic	Fluorofilm™	PVDF / Polyprel®	4FV	PE .375" O.D.	
	76HV	1.8	Acrylic / PP	316 S.S.	Fluorofilm™	Hypalon®		PE .5" O.D. Vinyl .938" O.D.	
	75HV	1.8	Polypropylene	316 S.S.	Fluorofilm™	PTFE		PE .5" O.D. Vinyl .938" O.D.	
	277	1.8	316 S.S.	316 S.S.	Fluorofilm™	316 S.S.		Pipe 1/4" NPT M	

■ See front page for voltage code specifications.

3FV indicates that the pump is equipped with an LMI Three Function Valve (pressure relief, priming aid, line drain).

Fluorofilm™ is a copolymer of PTFE and PFA. Polyprel® is an elastomeric PTFE copolymer.

† To specify 1/4" NPT male, change 'I' to 'P'. To specify black, UV resistant tubing, change 'I' to 'U'. To specify Bleed 4FV, change 'S' to 'B'. To specify 3FV, change 'S' to 'T'.

4FV indicates that the pump is equipped with an LMI Four Function Valve. This diaphragm type, anti-syphon/pressure relief valve is installed on the pump head. It provides anti-syphon protection and aids in priming, even under pressure.

Polyprel is a registered trademark of Liquid Metronics Incorporated. Fluorofilm and Liquifram are trademarks of Liquid Metronics Incorporated. Hypalon is a registered trademark of E. I. du Pont de Nemours & Co., Inc.

Output Information

Series	Gallons per Hour		Liters per Hour		mL/cc per Minute		mL/cc per Stroke		Maximum Injection Pressure	
	Min	Max	Min	Max	Min	Max	Min	Max		
P02	0.063	0.21	0.237	0.79	3.94	13	0.07	0.22	150 psi	(10.3 Bar)
P03	0.125	0.42	0.473	1.6	7.89	26	0.13	0.44	110 psi	(7.6 Bar)
P04	0.117	0.58	0.442	2.2	7.36	37	0.07	0.37	250 psi	(17.3 Bar)
P05	0.200	1.0	0.757	3.8	12.62	63	0.13	0.63	110 psi	(7.6 Bar)
P06	0.400	2.0	1.510	7.6	25.23	126	0.25	1.26	50 psi	(3.5 Bar)
P08	0.640	3.2	2.422	12.1	40.37	202	0.40	2.02	22 psi	(1.5 Bar)
P12	0.001	0.21	0.002	0.79	0.04	13	0.07	0.22	150 psi	(10.3 Bar)
P13	0.001	0.42	0.005	1.6	0.08	27	0.13	0.44	110 psi	(7.6 Bar)
P14, P74	0.001	0.58	0.004	2.2	0.07	37	0.07	0.37	250 psi	(17.3 Bar)
P15, P75	0.002	1.0	0.008	3.8	0.13	63	0.13	0.63	110 psi	(7.6 Bar)
P16, P76	0.004	2.0	0.015	7.6	0.25	126	0.25	1.26	110 psi	(7.6 Bar)
P18, P78	0.006	3.2	0.024	12.1	0.40	202	0.40	2.02	22 psi	(1.5 Bar)