

Configuration Data

Model AA9 4 1 - 358HI

Control Code

- 1 --- **Manual Control:** Speed (stroking frequency) and stroke length manually adjustable.
- 7 --- **Instrument Responsive/Manual Control:** Manual adjustment features of Control Code 1 plus switch conversion to external control for automatic systems.
- 9 --- **Microprocessor/Instrument Responsive:** External 4-20mA or pulse or x direct; manual stroke length control.

Output/Size Code

- 4 --- 0.58 GPH (2.2 l/h) --- 250 psi (17.3 Bar)
- 5 --- 1.00 GPH (3.8 l/h) --- 110 psi (7.6 Bar)
- 6 --- 2.00 GPH (7.6 l/h) --- 50 psi (3.5 Bar)
- 7 --- 0.42 GPH (1.6 l/h) --- 140 psi (9.7 Bar)
- 8 --- 0.75 GPH (2.8 l/h) --- 80 psi (5.5 Bar)

Voltage Code

- 1 --- 120 VAC, US Plug
- 2 --- 240 VAC, US Plug
- 3 --- 220-240 VAC, DIN Plug
- 5 --- 240-250 VAC, UK Plug
- 6 --- 240-250 VAC, Aust./NZ Plug
- 7 --- 220-240 VAC, Swiss Plug

Liquid End

See next page for complete liquid end specifications and selection.

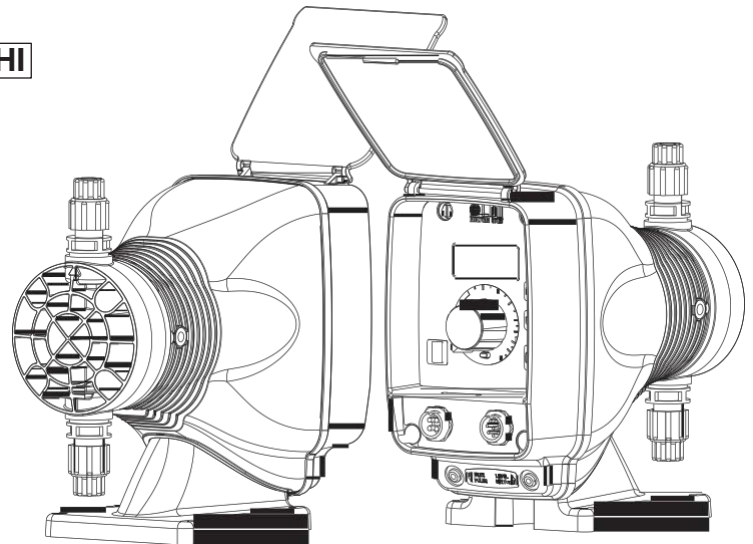

Dimensions

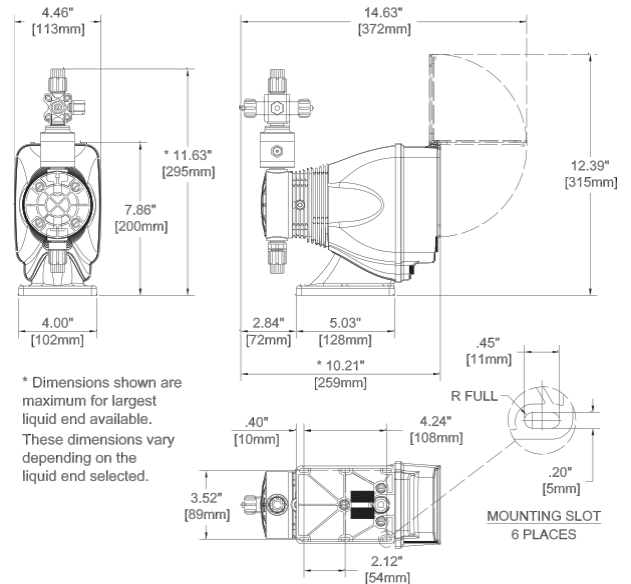

Specifications

Series	Strokes Per Minute (Adjustable)		Stroke Length (Adjustable) Recommended Minimum	Average Input Power @ Max Speed	Shipping Weight
	Min	Max			
AA14, AA74, AA94 AA15, AA75, AA95 AA16, AA76, AA96*	1	100	20%	22 watts	10 lbs (4.55 kg)
AA17, AA77, AA97* AA18, AA78	1	100	30%		

*Series 9 pumps may be programmed for strokes per hour for lower outputs.

Configuration Data & Materials of Construction

Drive Assembly	Liquid End No.	Size Code	Materials of Construction				Accessory	Tubing & Connections	
			Head & Fittings	Balls	Liquifram™	Check Valve		Discharge	Suction
AA97 AA94 AA77 AA74 AA17 AA14	458HI	0.5	PVC / PVC	Ceramic	Fluorofilm™	PVDF / Polyprel™	4FV + AV	PE .250" O.D.	
	450FI	0.5	Acrylic / PVC	PTFE	Fluorofilm™	PVDF / Polyprel™	4FV	PE .250" O.D.	
	450HI	0.5	Acrylic / PVC	Ceramic	Fluorofilm™	PVDF / Polyprel™	4FV + AV	PE .250" O.D.	
	358HI	0.5	PVC / PVC	Ceramic	Fluorofilm™	PVDF / Polyprel™	4FV + AV	PE .250" O.D.	
	353HI	0.5	PVDF / PVDF	Ceramic	Fluorofilm™	PVDF / PTFE	4FV + AV	PE .250" O.D.	
	352HI	0.5	PVDF / PVDF	Ceramic	Fluorofilm™	PVDF / Polyprel™	4FV + AV	PE .250" O.D.	
	155HV	0.5	Polypropylene	316 S.S.	Fluorofilm™	PTFE		PE .5" O.D. Vinyl .938" O.D.	
155S**	0.5	Polypropylene	Ceramic	Fluorofilm™	PTFE	4FV	PE .250" O.D.		
156HV	0.5	Acrylic/PP	316 S.S.	Fluorofilm™	Hypalon™		PE .5" O.D. Vinyl .938" O.D.		
257	0.5		316 S.S.	316 S.S.	Fluorofilm™	316 S.S.	Pipe 1/4" NPT M		

AA95 AA78 AA75 AA18 AA15	498HI	0.9	PVC / PVC	Ceramic	Fluorofilm™	PVDF / Polyprel™	4FV + AV	PE .375" O.D.	
	490HI	0.9	Acrylic / PVC	Ceramic	Fluorofilm™	PVDF / Polyprel™	4FV + AV	PE .375" O.D.	
	490FI	0.9	Acrylic / PVC	PTFE	Fluorofilm™	PVDF / Polyprel™	4FV	PE .375" O.D.	
	398HI	0.9	PVC / PVC	Ceramic	Fluorofilm™	PVDF / Polyprel™	4FV + AV	PE .375" O.D.	
	392HI	0.9	PVDF / PVDF	Ceramic	Fluorofilm™	PVDF / Polyprel™	4FV + AV	PE .375" O.D.	
	393HI	0.9	PVDF / PVDF	Ceramic	Fluorofilm™	PVDF / PTFE	4FV + AV	PE .375" O.D.	
	85HV	0.9	Polypropylene	316 S.S.	Fluorofilm™	PTFE		PE .5" O.D. Vinyl .938" O.D.	
	86HV	0.9	Acrylic / PP	316 S.S.	Fluorofilm™	Hypalon™		PE .5" O.D. Vinyl .938" O.D.	
	89	0.9	UHMW PE	Ceramic	Hypalon™	Hypalon™		PE .5" O.D. Vinyl .5" O.D.	
	95S**	0.9	Polypropylene	Ceramic	Fluorofilm™	PTFE	4FV	PE .375" O.D.	
	297	0.9		316 S.S.	316 S.S.	Fluorofilm™	316 S.S.	Pipe 1/4" NPT M	

AA96 AA76 AA16	468HI	1.8	PVC / PVC	Ceramic	Fluorofilm™	PVDF / Polyprel™	4FV + AV	PE .375" O.D.	
	460HI	1.8	Acrylic / PVC	Ceramic	Fluorofilm™	PVDF / Polyprel™	4FV + AV	PE .375" O.D.	
	460FI	1.8	Acrylic / PVC	PTFE	Fluorofilm™	PVDF / Polyprel™	4FV	PE .375" O.D.	
	368HI	1.8	PVC / PVC	Ceramic	Fluorofilm™	PVDF / Polyprel™	4FV + AV	PE .375" O.D.	
	362HI	1.8	PVDF / PVDF	Ceramic	Fluorofilm™	PVDF / Polyprel™	4FV + AV	PE .375" O.D.	
	363HI	1.8	PVDF / PVDF	Ceramic	Fluorofilm™	PVDF / PTFE	4FV + AV	PE .375" O.D.	
	65S**	1.8	Polypropylene	Ceramic	Fluorofilm™	PTFE	4FV	PE .375" O.D.	
	75HV	1.8	Polypropylene	316 S.S.	Fluorofilm™	PTFE		PE .5" O.D. Vinyl .938" O.D.	
	76HV	1.8	Acrylic / PP	316 S.S.	Fluorofilm™	Hypalon™		PE .5" O.D. Vinyl .938" O.D.	
	79	1.8	UHMW PE	Ceramic	Hypalon™	Hypalon™		PE .5" O.D. Vinyl .5" O.D.	
277	1.8		316 S.S.	316 S.S.	Fluorofilm™	316 S.S.	Pipe 1/4" NPT M		

■ See front page for voltage code specifications.

** These Liquid Ends are available without a 4FV, by removing the S from the liquid end code.

To specify 1/4 NPT male, change 'I' to 'P'.
 To specify black, UV resistant tubing, change 'I' to 'U'.
 To specify Bleed 4FV, change 'H' to 'B'.
 To specify 3FV, change 'H' to 'T'.
 To specify 4FV only, change 'H' to 'S'.
 To specify Auto Prime Valve only, change 'H' to 'A'.

3FV indicates that the pump is equipped with an LMI Three Function Valve (pressure relief, priming aid, line drain).

4FV indicates that the pump is equipped with an LMI Four Function Valve. This diaphragm type, anti-syphon/pressure relief valve is installed on the pump head. It provides anti-syphon protection and aids priming, even under pressure.

AV indicates that the pump is equipped with an LMI Auto Prime Valve. This valve allows for the constant removal of vapors and gases present in applications such as sodium hypochlorite and hydrogen peroxide.

Fluorofilm™ is a copolymer of PTFE and PFA. Polyprel™ is an elastomeric PTFE copolymer.

Polyprel is a registered trademark of Liquid Metronics Incorporated. Fluorofilm and Liquifram are trademarks of Liquid Metronics Incorporated. Hypalon is a registered trademark of E. I. du Pont de Nemours & Co., Inc.

Output Information

Series	Gallons per Hour		Liters per Hour		mL/cc per Minute		mL/cc per Stroke		Maximum Injection Pressure
	Min	Max	Min	Max	Min	Max	Min	Max	
AA94*, AA74*, AA14	0.001	0.58	0.004	2.2	0.07	37	0.07	0.37	250 psi (17.3 Bar)
AA95*, AA75*, AA15	0.002	1.00	0.008	3.8	0.13	63	0.13	0.63	110 psi (7.6 Bar)
AA96*, AA76*, AA16	0.004	2.00	0.015	7.6	0.25	126	0.25	1.26	50 psi (3.5 Bar)
AA97*, AA77*, AA17	0.001	0.42	0.005	1.6	0.08	26	0.08	0.26	140 psi (9.7 Bar)
AA78*, AA18	0.002	0.75	0.009	2.8	0.14	47	0.14	0.47	80 psi (5.5 Bar)

* Minimum output is based on one stroke per minute. Minimum output can be reduced further in external mode. Series AA9 pumps may be programmed for strokes per hour for lower outputs.