



SYGEF® PVDF



**Product Range
Export
1.11.2006**

List of Abbreviations

AL	Number of bolt holes	PN	Nominal pressure at 20°C, water
ANSI	American National Standard Institute	PP	Polypropylene, heat stabilised
d	Pipe outside diameter	PTFE	Polytetrafluorethylene, e.g. Teflon®
DIN	Deutsche Industrie-Normen	PVDF	Polyvinylidene fluoride
DN	Nominal bore	R	Taper male thread, pressure tight in the thread to ISO 7
e	Wall thickness	Rp	Parallel female thread, pressure tight in the thread to ISO 7
EPDM	Ethylene Propylene Rubber	the	Registered trade-mark A/F
FPM	Fluorine Rubber, e.g. Viton®	SC	Size of hexagon bolts
g	Weight in grams	SDR	Standard Dimension Ratio
G	Pipe thread, not pressure tight in the thread to ISO 288	SP	Standard pack. The figure given indicates the quantity of fittings contained in a standard pack
HP	High Purity	St	Steel
HTR	High Temperature Resistant	™	Trade-mark
ISO	International Standardization Organisation	Tr	Trapezoid thread
NBR	Nitrile Rubber		
NPT	Taper male thread pressure tight in the thread to ANSI B 1.20.1		
PBTP	Polybutylene therephthalate		

General Information

Dimensions

All dimensions are given in mm and are intended as nominal or average sizes. Subject to alteration resulting from modifications in design.

Ordering example

Pipe	d32	PVDF HP	175 481 669
Elbow 45°	d140	PVDF Standard	735 158 516

Orders

Always quote the Georg Fischer code number when placing orders.

SYGEF® is a registered trade-mark for Georg Fischer plastic piping systems as well as the system-oriented fusion machines.

Detailed technical information is given in our handbook «Planning Fundamentals» and also available under www.piping.georgfischer.com

Content – Fluoropolymers Product Range 2007

GF Piping Systems quality is no coincidence	4
Size Comparison	5
General information about PVDF	6
SYGEF Standard Piping System	9
- Pipes	
- Fittings	
- Manual Valves	
- Actuated Valves	
- Special Valves & Flowmeters	
SYGEF Plus Piping System	209
- Pipes	
- Fittings	
- Manual Valves	
- Actuated Valves	
- Special Valves & Flowmeters	
SYGEF Exhaust Ventilation System	283
- Pipes	
- Fittings	
SYGEF PFA Tubing System	289
FUSEAL 25/50 Drainage System	290
Semifinished Products	291
System Oriented Fusion Machines	293
- IR-Plus	
- BCF-Plus	
- SG110	
- Tools & Accessories for Pipe Jointing	
Standards and Conformances	309
Codenummer Index	321
Terms & Conditions of Supply	335

GF Piping Systems quality is no coincidence!

GF Piping systems has not only taken a pioneering role in the past for the range of PVC fittings and equipment, but also in the sector of fusible plastics.

GF Piping Systems developed the socket fusion jointing process 30 years ago, and

in later years also the BCF® and IR-Plus® fusion methods. More than 9 million IR & BCF fusion joints in the past 15 years world-wide has proven GF Piping Systems performance in jointing technology.

GF Piping Systems jointing technology for fluoropolymers

Jointing Method	SYGEF-Plus	SYGEF-Standard	SYGEF-Exhaust	SYGEF-PFA	FUSEAL 25/50
Heated Element Socket Fusion	-	X	-	-	-
Heated Element Butt Fusion	X ¹	X	-	-	X ²
Infrared (IR-Plus®) Fusion	X	X	-	X ²	-
Bead-and-Crevice-Free (BCF®) Fusion	X	X	-	-	-
Electrofusion with Integral Heating	-	-	-	-	X
Hot Air / Hot Gas Manual Fusion	X	X	X	X	X
Mechanical Jointing	X	X	X	X	X

X = Standard range
X² = On request only

X¹ = Technically possible, but not recommended
- = Not available

Hot Air / Hot Gas Manual Fusion is the standard jointing method for SYGEF-Exhaust, however it can be implemented on other systems as a repair method &/or for the processing of semifinished materials.

Component selection basis

SYGEF-Plus and SYGEF-Standard are system products, pipes and fittings are matched to each other, when selecting SYGEF PVDF fusion components to produce a system; the only consideration needs to be the fusion dimension; PN16 or PN10.

Mechanical joints such as flanges & threaded components are available in various industry standards:

- Flange connections to EN ISO 1092 or ANSI B16.5 #150 (JIS available on request)
- Threaded connections to ISO 7/1 & 228/1 (BSP) or NPT (JIS Rc available on request)
- Sanitary clamp connections to all standards worldwide
- Union connections to GF specification

Design Factors and derived operating pressures

In various standards for PVDF we find design factors (formerly called safety factors) stated, these are for water.

They are lower than the design factors recommended by GF Piping Systems for industrial applications. In order to protect human beings and the environment, those safety factors cannot be applied for industrial applications. We therefore recommend to use safety factors for SYGEF® piping systems as published in the following graph, for the calculation of piping system pressures for industrial applications.

For chemical applications, special considerations must be taken in determining appropriate safety factors, please consult GF for further information.

Size comparison – SS Tube to PVDF Pipe

DN, d, inch, nominal bore, o.d. – which is which?

Plastic piping in Inch sizes is typically sized on the nominal bore (DN) which is designated in inches. The outside diameter is fixed but is not mentioned.

Metric piping systems are sized on their outside diameter, with occasional mention of the DN size, when referring to valves or flanges.

Existing comparisons of metric sized pipes to Inch sizes pipes are well known, and generally the variation between Inch and Metric sizes (OD & ID) for the same DN is only a few millimetres.

e.g. The closest size to 1" Sch80 is d32 Metric, with both pipes being "DN25"

However, the sizing for SS tubes is often based on the outside diameter, and this does lead to some confusion. The table below demonstrates which PVDF size pipe is the closest match to SS Tubes in Inch & DIN, and to IPS / BS Inch pipe.

SS Tube Inch	SS Tube ISO/DIN	PVDF Pipe	IPS / BS Pipe
3/4"	DN20	d20	1/2"
1"	DN25	d25	3/4"
1 1/2" ^A	DN32	d32	1"
1 1/2"	DN40	d40	1 1/4"
2"	DN50	d50	1 1/2"
2 1/2"	DN65	d63	2"
3"	DN80	d75	2 1/2"
4" ^B	DN100 ^B	d90	3"
		d110	4"
5"	DN125	d125 ^C / d140 ^C	5"
6"	DN150	d160	6"
8"	-	d200	-
-	DN200	d200 or d225	8"

A = There is no 1 1/4" SS Tube Size in Inch dimensions; 3A, ASME-BPE or BS

B = 4" & DN100 SS Tube could transitioned to either d110 or d90 PVDF

C = 5" & DN125 Tube is closest to d125 PVDF, 5" IPS/BS is closest to d140 PVDF

8" SS tube is equivalent to d200 PVDF – DN200 SS Tube could be transitioned to either d200 or d225 PVDF

Further examples of this size comparison can be seen in the SYGEF-Plus Sanitary Clamp adaptors for transition to SS Tubes. As a "rule of thumb", the DN value of SS tube should be matched to the d value of PVDF pipe, but there are some exceptions depending upon which standard of SS Tube is employed.

→ In short, DN value is often not a clear indication of the required dimension.

SYGEF® PVDF General Information



- **Standard and High-Purity Pipes**
- **Socket Fusion System**
- **Butt Fusion (IR/BCF) System**
- **High-Purity Butt Fusion (IR/BCF) System**

SYGEF® Polyvinylidene fluoride (PVDF) virgin fluoropolymer

PVDF is a thermoplastic fluoropolymer with a melt point of 178°C and a wide service temperature range from -40°C to 140°C. The PVDF polymer chain is very linear and similar to PTFE Teflon® except it is not fully fluorinated and contains 3% hydrogen by weight. PVDF materials are ideal for use in aggressive chemical or ultrapure

water systems since they are basically inert, have high strength, and are readily weldable into system components. PVDF raw material is commonly available under the trade names Kynar®, supplied by Arkema Chemicals, and Solef®, supplied by Solvay Fluoropolymers.

Application limit of SYGEF pipes and fittings

(25-year values with design factor C included in the calculation = 2.0 & 1.6)

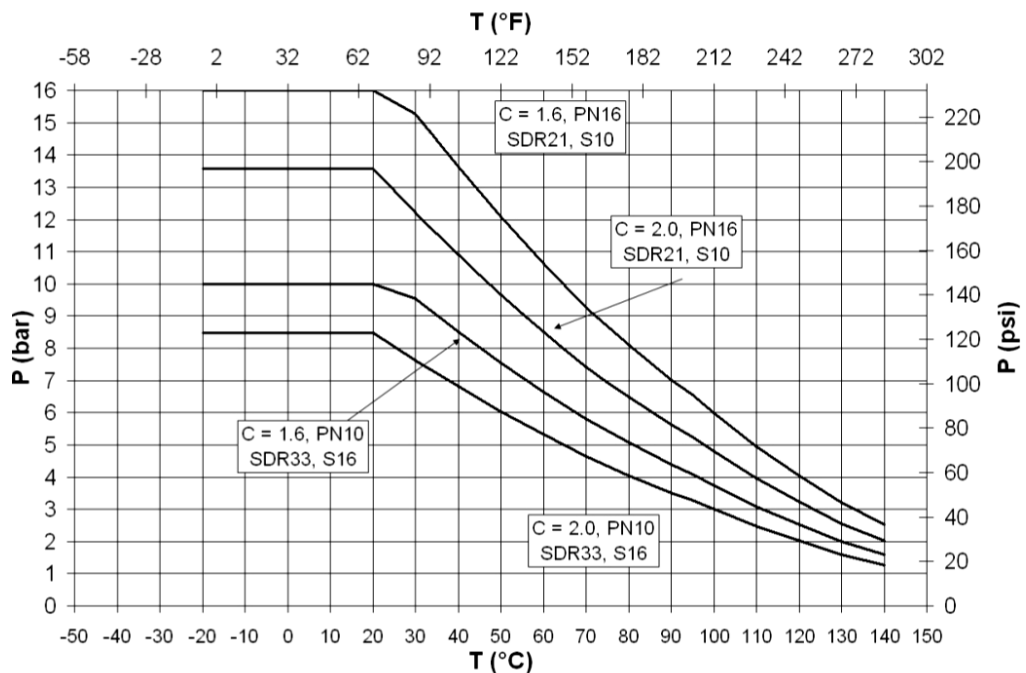

Dedicated Fluoropolymer Production

GF Piping Systems produces SYGEF® PVDF piping system components under cleanroom conditions in our state of the art high purity manufacturing facilities in Switzerland and Germany. The entire production process is designed, dedicated and operated to produce high quality PVDF components in both Standard and High-Purity grades. GF IR-Plus™ & BCF®Plus fusion technologies are substantial improvements over existing jointing methods such as contact butt fusion and socket fusion.

Completing the system are SYGEF® PVDF butt fusion fittings and valves specifically designed for use with IR-63 Plus, IR-225 Plus and IR-315 Plus fusion machines, and the BCF-Plus “Bead-&-Crevice-Free” Fusion machine.

For less demanding applications, GF also offers a comprehensive range of Fittings and Valves for Socket Fusion jointing up to the dimension d63.

GF Piping Systems Fluoropolymer Production – Ettenheim, Germany



Extrusion of Pipes & Tubes d16 – d400

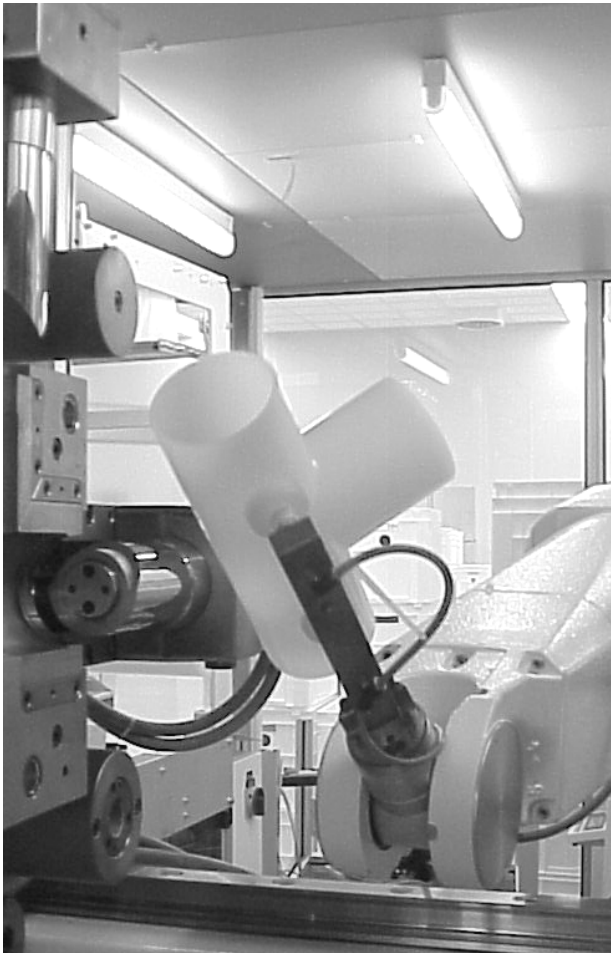















Injection Moulding



100% Visual Inspection

SYGEF® Standard

		Page
	Pipes	12
	Fittings for Butt Fusion	13
	Unions for Butt Fusion	20
	Transition Fittings for Butt Fusion	24
	Flange Adaptors, Flanges and Gaskets for Butt Fusion	26
	Fittings for Socket Fusion	32
	Unions for Socket Fusion	35
	Transition Fittings for Socket Fusion	39
	Flange Adaptors, Flanges and Gaskets for Socket Fusion	41
 DN10/15 - 50	Ball valves	47
	Diaphragm valves	63
	Butterfly valves	67
	Ball check valves	76
	Check valves	78



Ball valves silicon free/paint compatible

81



Ball check valve

84



Ball valves electric

86



Ball valves pneumatic

114



Diaphragm valves pneumatic

150



Butterfly valves electric

180



Butterfly valves pneumatic

188



Solenoid valves

197



Process control valves

201



Variable area flow meters

208

SYGEF® Standard – Product Specification

Material	Polyvinylidene fluoride (PVDF)
Colour	translucent
Density	~1.78g/cm ³ (ISO 1183 / ASTM D 792)
Surface tension	30–35mJ/m ²
Linear expansion coefficient	0.12–0.18mm/mK (DIN 53752)
E-module (tensile strength)	2100N/mm ² (ISO 527/ASTM D 790)
Thermal conductivity	0.19W/mK (DIN 52612)
Surface resistivity	5x10 ¹⁴ Ωcm (IEC 60093)
Dimension	d20 (½")–d225 (8") in accordance to ISO 10931
Pressure rating	Pipes/fittings: PN 16 (d20–d225), PN 10 (d90–d225) Valves: separate specification
Temperature rating	from –20°C to 140°C (–4°F–284°F)
Production	Fittings/valves: injection moulded Pipes: extruded Valves: injection moulded (additional available oil free treated and paint compatible /silicon free)
Surface finish	Inner surface Ra ≤0.5µm (20µin) for injection moulded and extruded components
Marking	All components are embossed with a permanent identification during the production process to ensure full traceability. Lot No Material Dimension Pressure Rating
Testing and inspection (ISO 10931)	Inclusions Visual inspection Surface finish Dimension tolerance Pressure testing
Approvals/conformance⁽¹⁾	ASME BPE FDA CFR 21 177.2510 USP 25 class VI (physiological non-toxic)
Welding technology	BCF® Plus, bead and crevice free fusion, size d20 (½")–d110 (4") IR® Plus, infrared fusion (DVS 2207-6), size d20 (½")–d225 (8") BF, butt fusion (DVS 2207-15)
Documentation⁽²⁾	Certificate of Conformance with FDA, USP EN 10204 2.2 EN 10204 3.1b
Packing⁽³⁾	Multiple components single bagged in specified bag
Labeling	Brand Name Product Description Code Number Material Dimension CE-labeling
Main applications	Uses include delivery of pharmaceutical grade purified water (PW) and DI water, using hot water, steam chemical or ozone sanitisation. Due to its excellent chemical resistance it is widely used in chemical distribution systems.

⁽¹⁾ For thermoplastic material only

⁽²⁾ on request

⁽³⁾ not for socket fusion products

Pipes

75 48 02

Pipe, PN 16, PVDF-Standard

H

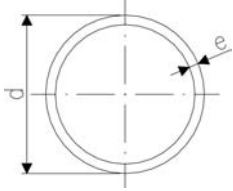

PF 2 35 188

d [mm]	PN	Code	e [mm]	Weight [kg/m]	Length [m]
16	16	175 480 202	1.9	0.171	5.00
20	16	175 480 203	1.9	0.209	5.00
25	16	175 480 204	1.9	0.278	5.00
32	16	175 480 205	2.4	0.425	5.00
40	16	175 480 206	2.4	0.550	5.00
50	16	175 480 207	3.0	0.835	5.00
63	16	175 480 208	3.0	1.080	5.00
75	16	175 480 209	3.6	1.519	5.00
90	16	175 480 210	4.3	2.232	5.00
110	16	175 480 211	5.3	3.336	5.00
140	16	175 480 213	6.7	5.310	5.00
160	16	175 480 214	7.7	6.960	5.00
200	16	175 480 216	9.6	10.800	5.00
225	16	175 480 217	10.8	13.700	5.00

75 48 06

Pipe, PN 10, PVDF-Standard

H

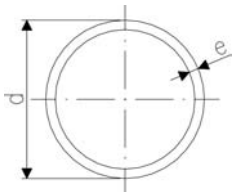

PF 2 35 188

d [mm]	PN	Code	e [mm]	Weight [kg/m]	Length [m]
90	10	175 480 665	2.8	1.565	5.00
110	10	175 480 666	3.4	2.140	5.00
125	10	175 480 667	3.9	2.800	5.00
140	10	175 480 673	4.3	3.710	5.00
160	10	175 480 668	4.9	4.657	5.00
200	10	175 480 669	6.2	6.916	5.00
225	10	175 480 670	6.9	9.162	5.00
250	10	175 480 671	7.7	11.100	5.00
280	10	175 480 656	8.6	13.900	5.00
315	10	175 480 674	9.7	17.600	5.00

Fittings for Butt Fusion

35 01 87

Bend 90°, PN 16, PVDF-Standard

K

- * new model with compact design and optimized flow values

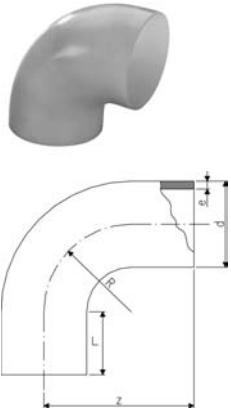

PF 2 35 190

d [mm]	PN	Code	kg	e [mm]	L [mm]	z [mm]	R [mm]
*20	16	735 018 706	0.015	1.9	23	38	15
*25	16	735 018 707	0.021	1.9	23	42	19
*32	16	735 018 708	0.035	2.4	22	46	24
*40	16	735 018 709	0.050	2.4	21	51	30
*50	16	735 018 710	0.087	3.0	21	58	37
*63	16	735 018 711	0.128	3.0	21	66	45
75	16	735 018 712	0.243	3.6	23	75	62
90	16	735 018 713	0.385	4.3	23	90	77
110	16	735 018 714	0.643	5.3	23	110	98
140	16	735 018 716	1.423	6.7	33	140	121
160	16	735 018 717	2.052	7.7	33	160	141
200	16	735 018 719	3.798	9.6	33	200	181
225	16	735 018 720	5.274	10.8	33	220	200

35 01 85

Bend 90°, PN 10, PVDF-Standard

K

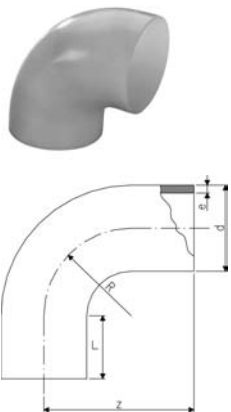

PF 2 35 190

d [mm]	PN	Code	kg	e [mm]	L [mm]	z [mm]	R [mm]
90	10	735 018 513	0.294	2.8	23	90	77
110	10	735 018 514	0.578	3.4	23	110	98
125	10	735 018 515	0.670	3.9	28	125	112
140	10	735 018 516	0.970	4.3	33	140	121
160	10	735 018 517	1.440	4.9	33	160	141
200	10	735 018 519	2.730	6.2	33	200	181
225	10	735 018 520	3.900	6.9	33	220	200

35 10 86

Elbow 90°, PN 16, PVDF-Standard

K

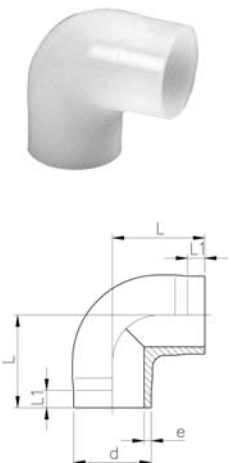

PF 2 35 190

d [mm]	PN	Code	kg	e [mm]	L [mm]	L1 [mm]
20	16	735 108 606	0.017	1.9	38	25
25	16	735 108 607	0.023	1.9	42	26
32	16	735 108 608	0.040	2.4	46	26
40	16	735 108 609	0.060	2.4	51	28
50	16	735 108 610	0.105	3.0	58	28
63	16	735 108 611	0.180	3.0	66	28

35 15 86

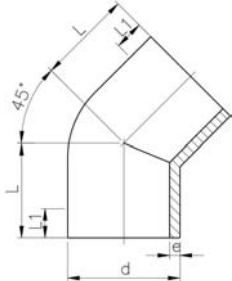
Elbow 45°, PN 16, PVDF-Standard**K**

PF 2 35 190

d [mm]	PN	Code	kg	e [mm]	L [mm]	L1 [mm]
20	16	735 158 606	0.014	1.9	32	25
25	16	735 158 607	0.019	1.9	34	26
32	16	735 158 608	0.033	2.4	36	26
40	16	735 158 609	0.048	2.4	39	28
50	16	735 158 610	0.079	3.0	42	30
63	16	735 158 611	0.116	3.0	47	31
75	16	735 158 612	0.160	3.6	49	32
90	16	735 158 613	0.260	4.3	57	37
110	16	735 158 614	0.480	5.3	70	46
140	16	735 158 616	1.000	6.7	88	57
160	16	735 158 617	1.470	7.7	100	62
200	16	735 158 619	2.800	9.6	124	77
225	16	735 158 620	4.000	10.8	140	88

35 15 85

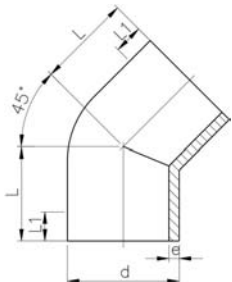
Elbows 45°; PN 10, PVDF-Standard**K**

PF 2 35 190

d [mm]	PN	Code	kg	e [mm]	L [mm]	L1 [mm]
90	10	735 158 513	0.181	2.8	57	37
110	10	735 158 514	0.330	3.4	70	46
125	10	735 158 515	0.490	3.9	79	51
140	10	735 158 516	0.680	4.3	88	57
160	10	735 158 517	0.990	4.9	100	62
200	10	735 158 519	1.940	6.2	124	77
225	10	735 158 520	2.780	6.9	140	88

35 20 86

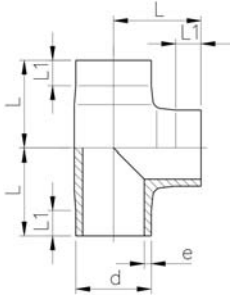
T 90° equal, PN 16, PVDF-Standard**K**

PF 2 35 190

d [mm]	PN	Code	kg	e [mm]	L [mm]	L1 [mm]
20	16	735 208 606	0.023	1.9	38	25
25	16	735 208 607	0.032	1.9	42	27
32	16	735 208 608	0.056	2.4	46	27
40	16	735 208 609	0.083	2.4	51	28
50	16	735 208 610	0.140	3.0	58	28
63	16	735 208 611	0.231	3.0	66	28
75	16	735 208 612	0.370	3.6	75	32
90	16	735 208 613	0.660	4.3	90	39
110	16	735 208 614	1.210	5.3	110	48
140	16	735 208 616	2.600	6.7	140	62
160	16	735 208 617	3.500	7.7	160	71
200	16	735 208 619	7.500	9.6	200	80
225	16	735 208 620	10.600	10.8	220	86

35 20 85

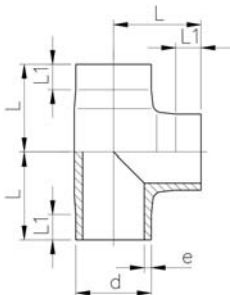
T 90° equal, PN 10, PVDF-Standard**K**

PF 2 35 190

d [mm]	PN	Code	kg	e [mm]	L [mm]	L1 [mm]
90	10	735 208 513	0.397	2.8	90	39
110	10	735 208 514	0.714	3.4	110	48
125	10	735 208 515	1.280	3.9	125	56
140	10	735 208 516	1.780	4.3	140	62
160	10	735 208 517	2.570	4.9	160	71
200	10	735 208 519	4.297	6.2	200	80
225	10	735 208 520	7.250	6.9	220	86

35 20 86

T 90° reduced, PN 16, PVDF-Standard

K

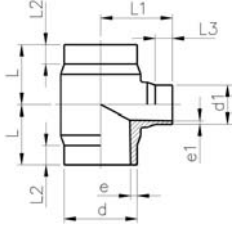

PF 2 35 426

d - d1 [mm]	PN	Code	kg	e [mm]	e1 [mm]	L [mm]	L1 [mm]	L2 [mm]	L3 [mm]
160 - 90	16	735 208 662	3.200	7.7	4.3	155	130	60	25
160 - 110	16	735 208 661	3.300	7.7	5.3	155	130	60	25
225 - 90	16	735 208 670	6.000	10.8	4.3	155	160	60	25
225 - 110	16	735 208 669	6.100	10.8	5.3	155	160	60	25

35 20 85

T 90° reduced, PN 10, PVDF-Standard

K

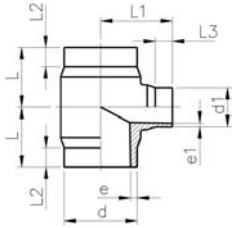

PF 2 35 426

d - d1 [mm]	PN	Code	kg	e [mm]	e1 [mm]	L [mm]	L1 [mm]	L2 [mm]	L3 [mm]
160 - 90	10	735 208 562	2.300	4.9	4.3	155	130	60	25
160 - 110	10	735 208 561	2.300	4.9	5.3	155	130	60	25
225 - 90	10	735 208 570	4.400	6.9	4.3	155	160	60	25
225 - 110	10	735 208 569	4.400	6.9	5.3	155	160	60	25

35 91 88

Instrument Installation Fitting, PN 16, PVDF-HP

K

Model:

- Suitable for hole diameters from 1/4 - 3/4
- Injection-moulded version

Note:

- Hole needs to be milled, HAND HELD DRILLING MUST NOT BE DONE

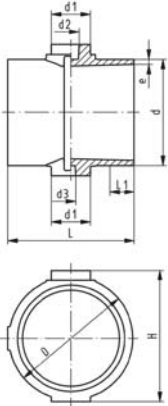

PF 2 37 425

d [mm]	PN	Code	kg	D [mm]	e [mm]	d1 [mm]	d2 [mm]	H [mm]	L [mm]	L1 [mm]
63	16	735 918 811	0.235	85	3.0	40	17	89	120	25
75	16	735 918 812	0.326	96	3.6	40	17	101	130	25
90	16	735 918 813	0.418	110	4.3	40	17	116	130	25
110	16	735 918 814	0.561	127	5.3	40	17	136	130	25

35 91 86

Instrument Installation Fitting, PN 16, PVDF-HP

K

Model:

- Suitable for hole diameters from 1/8 - 3/4
- Machined version

Note:

- Hole needs to be milled, HAND HELD DRILLING MUST NOT BE DONE

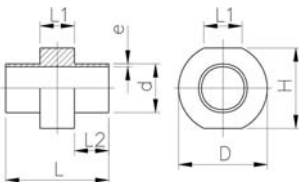

PF 2 37 425

* no stock item

d [mm]	PN	Code	kg	D [mm]	e [mm]	H [mm]	L [mm]	L1 [mm]	L2 [mm]
*63	16	735 918 611	0.495	105	3.0	97	100	40	27
*75	16	735 918 612	0.554	115	3.6	108	90	40	22
*90	16	735 918 613	0.649	128	4.3	121	90	40	22
*110	16	735 918 614	0.778	145	5.3	139	90	40	22
*125	16	735 918 615	1.007	162	6.0	157	100	40	27
*140	16	735 918 616	1.185	176	6.7	171	110	40	32
*160	16	735 918 617	1.405	194	7.7	190	110	40	32
*200	16	735 918 619	1.871	231	9.6	228	110	40	32
*225	16	735 918 620	2.284	254	10.8	251	110	40	32

35 91 85

Instrument Installation Fitting, PN 10, PVDF-HP

K

Model:

- Suitable for hole diameters from 1/8 - 3/4
- Machined version

Note:

- Hole needs to be milled, HAND HELD DRILLING MUST NOT BE DONE

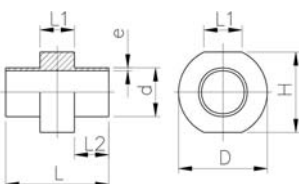

PF 2 37 425

d [mm]	PN	Code	kg	D [mm]	e [mm]	H [mm]	L [mm]	L1 [mm]	L2 [mm]
125	10	735 918 565	0.858	162	3.9	157	100	40	27
140	10	735 918 566	1.003	176	4.4	171	110	40	32
160	10	735 918 567	1.151	194	4.9	190	110	40	32
200	10	735 918 569	1.486	231	6.2	228	110	40	32
225	10	735 918 570	3.151	254	7.0	251	110	40	32

SYGEF® Standard Sensor Connection Tee

The maximal solution
for a minimal dead leg



Your benefit with the Sensor Connection Tee:

- Easier cleaning (CIP)
- Minimal Biofilm building up
- Reduced installation costs
- Compact design
- Reliable sensor connection
- Fulfills FDA and USP class VI

All available standards:

- ISO 1127
- DIN 32676
- ASME BPE
- MM
- 3A
- ISO 2852
- BS 4825 Metric & Inch
- DIN 3017
- JIS G3447
- SYGEF-Plus

The SCT at a glance:

- Main line sizes d20 to d110 compatible with IR-Plus® & BCF®Plus fusion
- PN16 welding dimension (PN10 for d90 & d110 also available)
- Clamp connection up from d20 to d75 depending on main line dimension
- Fully customised solution, to suit your application

→ Please contact GF for further technical information

35 90 86

Reducer, PN 16, PVDF-Standard

K

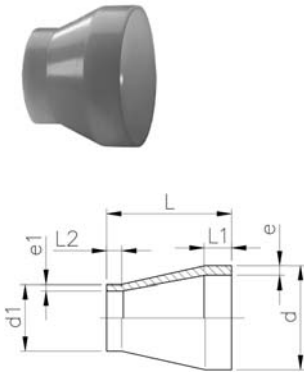

d - d1 [mm]	PN	Code	kg	e [mm]	e1 [mm]	L [mm]	L1 [mm]	L2 [mm]
25 - 20	16	735 908 637	0.012	1.9	1.9	50	22	22
32 - 20	16	735 908 642	0.017	2.4	1.9	50	22	22
32 - 25	16	735 908 641	0.018	2.4	1.9	50	22	22
40 - 20	16	735 908 648	0.024	2.4	1.9	58	22	24
40 - 25	16	735 908 647	0.025	2.4	1.9	55	22	24
40 - 32	16	735 908 646	0.029	2.4	2.4	55	22	24
50 - 25	16	735 908 654	0.031	3.0	1.9	60	22	25
50 - 32	16	735 908 653	0.038	3.0	2.4	60	22	25
50 - 40	16	735 908 652	0.040	3.0	2.4	60	22	25
63 - 32	16	735 908 660	0.050	3.0	2.4	65	22	25
63 - 40	16	735 908 659	0.052	3.0	2.4	65	22	25
63 - 50	16	735 908 658	0.060	3.0	3.0	65	22	25
75 - 40	16	735 908 666	0.069	3.6	2.4	68	24	25
75 - 50	16	735 908 665	0.078	3.6	3.0	65	24	25
75 - 63	16	735 908 664	0.080	3.6	3.0	65	24	25
90 - 63	16	735 908 671	0.120	4.3	3.0	75	25	30
90 - 75	16	735 908 670	0.130	4.3	3.6	75	25	35
110 - 63	16	735 908 678	0.225	5.3	3.0	90	30	30
110 - 75	16	735 908 677	0.213	5.3	3.6	90	30	35
110 - 90	16	735 908 676	0.230	5.3	4.3	90	30	35
140 - 110	16	735 908 685	0.450	6.7	5.3	110	40	40
160 - 110	16	735 908 690	0.650	10.8	9.6	160	55	50
160 - 140	16	735 908 688	0.450	7.7	5.3	120	40	40
200 - 160	16	735 908 692	1.340	7.7	6.7	120	40	35
225 - 110	16	735 908 695	1.540	10.8	5.3	160	50	40
225 - 160	16	735 908 696	1.730	10.8	5.3	160	50	40
225 - 200	16	735 908 697	1.980	10.8	7.7	160	55	28

PF 2 35 190

35 90 85

Reducer, PN 10, PVDF-Standard

K

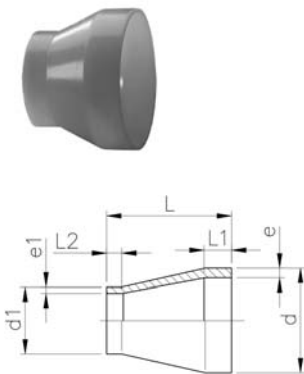

d - d1 [mm]	PN [bar]	Code	kg	e [mm]	e1 [mm]	L [mm]	L1 [mm]	L2 [mm]
90 - 63	10 / 16	735 908 551	0.102	2.8	3.0	75	25	30
110 - 63	10 / 16	735 908 553	0.164	3.4	3.0	90	30	30
110 - 90	10 / 10	735 908 555	0.167	3.4	2.8	90	30	35
125 - 110	10 / 16	735 908 580	0.270	3.9	5.3	100	35	40
140 - 110	10 / 16	735 908 585	0.385	4.3	5.3	110	40	40
140 - 125	10 / 10	735 908 584	0.340	4.3	3.9	110	40	40
160 - 110	10 / 10	735 908 561	0.449	4.9	3.4	120	40	40
160 - 110	10 / 16	735 908 590	0.425	4.9	5.3	120	40	40
160 - 140	10 / 10	735 908 588	0.460	4.9	4.3	120	40	40
200 - 160	10 / 10	735 908 592	0.830	6.2	4.9	145	50	40
225 - 110	10 / 10	735 908 566	1.120	6.9	3.4	160	55	35
225 - 110	10 / 16	735 908 595	0.940	6.9	5.3	160	55	35
225 - 160	10 / 10	735 908 596	1.140	6.9	4.9	160	55	40
225 - 200	10 / 10	735 908 597	1.200	6.9	6.2	160	55	50

PF 2 35 190

Unions for Butt Fusion

35 52 86

Union (FPM black), PN 16, PVDF-Standard

K

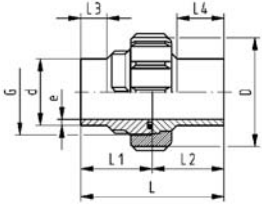

Model:

- supplied with sealing
- d75, d90 and d110 with buttress shaped thread

Note:

- For the dimensions d75-110 please see instructions for the installation

d [mm]	PN	Code	kg	D [mm]	e [mm]	L [mm]	L1 [mm]	L2 [mm]	L3 [mm]
20	16	735 528 606	0.081	45	1.9	107	53	53	25
25	16	735 528 607	0.123	55	1.9	112	56	56	25
32	16	735 528 608	0.167	62	2.4	119	59	59	25
40	16	735 528 609	0.269	75	2.4	125	62	63	25
50	16	735 528 610	0.370	84	3.0	130	65	66	25
63	16	735 528 611	0.592	101	3.0	136	68	69	25
75	16	735 528 612	0.740	133	3.6	131	66	66	24
90	16	735 528 613	0.730	133	4.3	131	66	65	24
110	16	735 528 614	1.020	155	5.3	131	66	65	25

PF 2 35 421

35 60 86

Union end, PN 16, PVDF-Standard

K

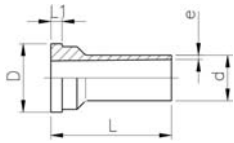

Model:

- Suitable for SYGEF® Standard Union Butt Fusion
- Suitable for Diaphragm Valve Type 314
- Suitable for Vortex Sensor

d [mm]	PN	Code	kg	D [mm]	e [mm]	L [mm]	L1 [mm]
20	16	735 608 606	0.020	30	1.9	53	5
25	16	735 608 607	0.029	39	1.9	56	5
32	16	735 608 608	0.041	45	2.4	59	6
40	16	735 608 609	0.069	57	2.4	63	6
50	16	735 608 610	0.094	63	3.0	66	7
63	16	735 608 611	0.144	78	3.0	69	8
75	16	735 608 612	0.188	101	3.6	66	9
90	16	735 608 613	0.184	101	4.3	65	9
110	16	735 608 614	0.260	121	5.3	65	10

PF 2 35 421

Blanking Union End

d [mm]	d [inch]	PN	DN [mm]	Code	SP	kg	A [mm]	B [mm]	C [inch]	D [mm]
20		232	0	175 482 101	-	0.007				
25		232	0	175 482 102	-	0.015	1	1	1	0
32		232	0	175 482 103	-	0.025	2	1	1	0
50		232	0	175 482 105	-	0.060				
63		232	0	175 482 106	-	0.110				

PF 2 65 434

24 60 06

Union Ends, Stainless Steel 1.4404 (316L)**Rp****A****Model:**

- Parallel female thread Rp

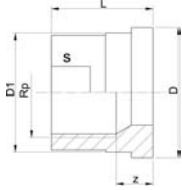

PF 2 30 153

Rp [inch]	PN	Code	SP	kg	z [mm]	D [mm]	D1 [mm]	L [mm]	s [mm]
3/8	16	724 600 655	-	0.030	9	24	22	19	19
1/2	16	724 600 656	-	0.060	11	30	28	24	24
3/4	16	724 600 657	-	0.100	11	39	36	26	29
1	16	724 600 658	-	0.140	12	45	42	29	36
1 1/4	16	724 600 659	-	0.230	14	57	53	33	45
1 1/2	16	724 600 660	-	0.320	15	63	59	34	54
2	16	724 600 661	-	0.450	15	78	74	39	63

24 60 07

Union Ends, Stainless Steel 1.4404 (316L)**R****A****Model:**

- Taper male thread R

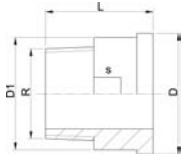

PF 2 30 153

R [inch]	PN	Code	SP	kg	D [mm]	D1 [mm]	L [mm]	s [mm]
3/8	16	724 600 705	-	0.050	24	22	30	19
1/2	16	724 600 706	-	0.090	30	28	34	24
3/4	16	724 600 707	-	0.120	39	36	36	32
1	16	724 600 708	-	0.190	45	42	40	37
1 1/4	16	724 600 709	-	0.350	57	53	46	48
1 1/2	16	724 600 710	-	0.400	63	59	48	54
2	16	724 600 711	-	0.660	78	74	55	69

24 60 55

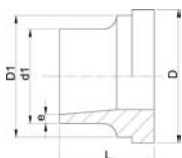
Union Ends, Stainless Steel 1.4404 (316L)**Welding End****A**

PF 2 30 153

d [mm]	d1 [mm]	PN	Code	SP	kg	D [mm]	D1 [mm]	L [mm]	e [mm]
16	17	16	724 605 505	-	0.030	24	22	18	1.6
20	21	16	724 605 506	-	0.050	30	28	22	2.0
25	26	16	724 605 507	-	0.080	39	36	23	2.0
32	33	16	724 605 508	-	0.110	45	42	26	2.0
40	42	16	724 605 509	-	0.190	57	53	26	2.0
50	48	16	724 605 510	-	0.220	63	59	28	2.0
63	60	16	724 605 511	-	0.370	78	74	32	2.6

35 69 04

Union nut, PN16, PVDF-Standard**J**

- d75, d90 and d110 with buttress shaped thread

Note:

- For the dimensions d75-110 please see instructions for the installation

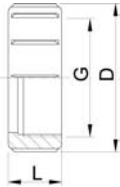

PF 2 35 191

Socket Fusion d [mm]	Butt Fusion d [mm]	PN	Code	kg	D [mm]	G [inch]	L [mm]	
16	16	16	735 690 405	0.013	35	3/4	21	
20	20	16	735 690 406	0.023	45	1	22	
25	25	16	735 690 407	0.047	55	1 1/4	24	
32	32	16	735 690 408	0.048	62	1 1/2	26	
40	40	16	735 690 409	0.097	75	2	29	
50	50	16	735 690 410	0.146	84	2 1/4	33	
63	63	16	735 690 411	0.244	101	2 3/4	35	

24 69 01

Union nut stainless steel 1.4404 (316L)**A**

* Octagon union nut

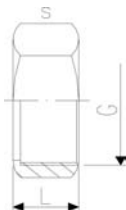

PF 2 30 153

d [mm]	PN	Code	SP	kg	L [mm]	G [inch]	s [mm]	
16	16	724 690 105	-	0.060	19	3/4	32	
20	16	724 690 106	-	0.110	21	1	41	
25	16	724 690 107	-	0.100	23	1 1/4	46	
32	16	724 690 108	-	0.170	24	1 1/2	55	
*40	16	724 690 109	-	0.240	27	2	68	
*50	16	724 690 110	-	0.300	31	2 1/4	74	
*63	16	724 690 111	-	0.390	35	2 3/4	88	

35 64 86

Union bush, PN 16, PVDF-Standard**K****Model:**

- Suitable for SYGEF® Standard Union Butt Fusion
- d75, d90 and d110 with buttress shaped thread

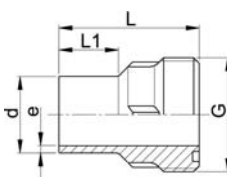

PF 2 35 421

d [mm]	PN	Code	kg	G [inch]	e [mm]	L [mm]	L1 [mm]	
20	16	735 648 606	0.029	1	1.9	53	25	
25	16	735 648 607	0.045	1 1/4	4.9	56	25	
32	16	735 648 608	0.063	1 1/2	2.4	59	25	
40	16	735 648 609	0.098	2	2.4	62	25	
50	16	735 648 610	0.124	2 1/4	3.0	65	25	
63	16	735 648 611	0.195	2 3/4	3.0	68	25	
75	16	735 648 612	0.272	S 107.5 x 3.6	3.6	66	24	
90	16	735 648 613	0.273	S 107.5 x 3.6	4.3	66	24	
110	16	735 648 614	0.364	S 127.5 x 3.6	5.3	66	25	

EPDM 48 41 00
FPM 49 41 00

O-Ring Gaskets

A

Model:

- For unions
- Hardness approx. 65° Shore
- EPDM minimum temperature -40°C
- FPM minimum temperature -15°C

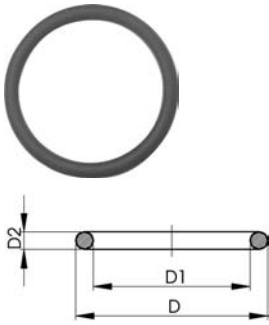

PF 2 30 162

d [mm]	DN [mm]	EPDM Code	FPM Code	SP	kg	D [mm]	D1 [mm]	D2 [mm]
10-12	8	748 410 004	749 410 004	-	0.002	18	12	3
16	10	748 410 005	749 410 005	-	0.002	21	16	3
20	15	748 410 006	749 410 006	-	0.002	27	20	4
25	20	748 410 007	749 410 007	100	0.002	35	28	4
32	25	748 410 008	749 410 008	100	0.002	40	33	4
40	32	748 410 009	749 410 009	-	0.006	51	41	5
50	40	748 410 010	749 410 010	-	0.007	58	47	5
63	50	748 410 011	749 410 011	100	0.010	70	60	5
75	65	748 410 014	749 410 014	100	0.012	93	82	5
90	80	748 410 015	749 410 015	100	0.015	112	101	5
110	100	748 410 016	749 410 016	50	0.031	134	120	7

O-Ring Gaskets

Model:

- For unions
- Hardness approx. 75° Shore
- FFPM minimum temperature -20°C

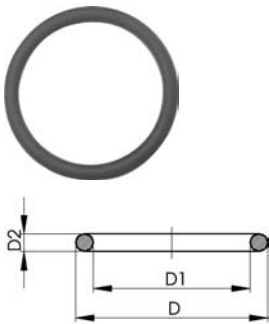

PF 2 3 0 1

d [mm]	DN [mm]	FFPM Code	D [mm]	D1 [mm]	D2 [mm]
20	15	700 245 481	27	20	4
25	20	700 245 482	35	28	4
32	25	700 245 483	40	33	4
40	32	700 245 484	51	41	5
50	40	700 245 485	58	47	5
63	50	700 245 486	70	60	5

Transition Fittings for Butt Fusion

35 91 05

Adaptor Nipple, male thread - R, PN 16, PVDF-Standard **K**

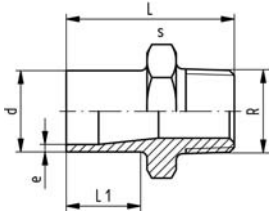

PF 2 35 421

Model:

- With butt fusion spigot and BSP tapered male thread
- Connection to plastic thread only
- Do not use thread sealing pastes that are harmful to PVDF
- Avoid stresses when installing and large changes in temperature

d [mm]	R [inch]	PN	Code	kg	e [mm]	L [mm]	s [mm]	L1 [mm]
20	3/8	16	735 910 555	0.023	1.9	50	32	26
20	3/8	16	735 910 556	0.025	1.9	53	32	26
25	3/4	16	735 910 557	0.032	1.9	55	36	26
32	1	16	735 910 558	0.051	2.4	57	46	26
40	1 1/4	16	735 910 559	0.075	2.4	60	55	26
50	1 1/2	16	735 910 560	0.112	3.0	63	65	26
63	2	16	735 910 561	0.179	3.0	69	75	27

35 91 45

Adaptor Nipple, male thread - NPT, PN 16, PVDF-Standard **K**

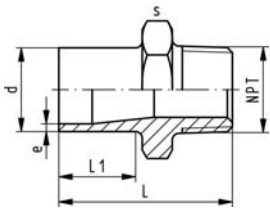

PF 2 35 421

Model:

- With butt fusion spigot and taper male thread
- Connection to plastic thread only
- Do not use thread sealing pastes that are harmful to PVDF
- Avoid stresses when installing and large changes in temperature

d [mm]	NPT [inch]	PN	Code	kg	e [mm]	L [mm]	s [mm]	L1 [mm]
20	3/8	16	735 914 555	0.023	1.9	50	32	28
20	1/2	16	735 914 556	0.025	1.9	53	32	28
25	3/4	16	735 914 557	0.032	1.9	55	36	28
32	1	16	735 914 558	0.052	2.4	57	46	28
40	1 1/4	16	735 914 559	0.075	2.4	60	55	28
50	1 1/2	16	735 914 560	0.112	3.0	63	65	28
63	2	16	735 914 561	0.179	3.0	69	75	29

35 91 02

Adaptor Socket, female thread - Rp, PN16, PVDF-Standard **K**

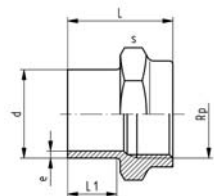

PF 2 35 421

Model:

- With butt fusion spigot and BSP parallel female thread
- Connection to plastic thread only
- Do not use thread sealing pastes that are harmful to PVDF
- Avoid stresses when installing and large changes in temperature

d [mm]	Rp [inch]	PN	Code	kg	e [mm]	L [mm]	s [mm]	L1 [mm]
20	3/8	16	735 910 265	0.030	1.9	49	32	23
20	1/2	16	735 910 266	0.026	1.9	49	32	23
25	3/4	16	735 910 267	0.032	1.9	51	36	23
32	1	16	735 910 268	0.058	2.4	54	46	23
40	1 1/4	16	735 910 269	0.079	2.4	56	55	23
50	1 1/2	16	735 910 270	0.100	3.0	60	65	24
63	2	16	735 910 271	0.001	3.0	62	75	23

35 91 42

Adaptor Socket, female thread - NPT, PN 16, PVDF-Standard

K

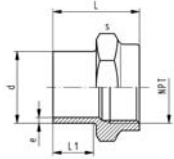

Model:

- With butt fusion spigot and taper female thread
- Connection to plastic thread only
- Do not use thread sealing pastes that are harmful to PVDF
- Avoid stresses when installing and large changes in temperature

d [mm]	NPT [inch]	PN	Code	kg	e [mm]	L [mm]	s [mm]	L1 [mm]
20	3/8	16	735 914 265	0.030	1.9	49	32	28
20	1/2	16	735 914 266	0.026	1.9	49	32	28
25	3/4	16	735 914 267	0.032	1.9	51	36	28
32	1	16	735 914 268	0.058	2.4	54	46	28
40	1 1/4	16	735 914 269	0.079	2.4	57	55	28
50	1 1/2	16	735 914 270	0.001	3.0	60	65	28
63	2	16	735 914 271	0.001	3.0	64	75	29

PF 2 35 421

35 96 86

Hose Adapter, PN 16, PVDF-Standard

K

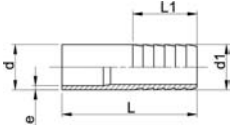

Model:

- With butt fusion spigot

d - d1 [mm]	PN	e [mm]	L [mm]	L1 [mm]	Code	kg
20 - 20	16	1.9	64	27	735 968 606	0.001
25 - 25	16	1.9	75	36	735 968 607	0.001
32 - 32	16	2.4	82	36	735 968 608	0.001
40 - 40	16	2.4	84	42	735 968 609	0.001
50 - 50	16	3.0	90	48	735 968 610	0.084
63 - 60	16	3.0	100	50	735 968 611	0.118

PF 2 35 421

Flange Adaptors, Flanges and Gaskets for Butt Fusion

35 79 88

Flange Adaptors, PN16, jointing face serrated, PVDF-Standard

K

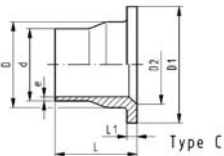
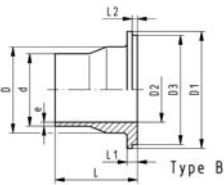
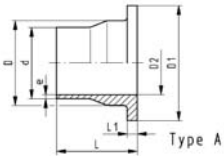

PF 2 35 190

d [mm]	DN [mm]	PN	Code	kg	D [mm]	D1 [mm]	D2 [mm]	D3 [mm]	e [mm]	L [mm]	L1 [mm]	L2 [mm]	Type
20	15	16	735 798 806	0.029	26	45	15		1.9	54	6		A
25	20	16	735 798 807	0.044	32	58	20	54	1.9	56	7	4	B
32	25	16	735 798 808	0.066	40	68	26	63	2.4	58	7	4	B
40	32	16	735 798 809	0.093	49	78	34	73	2.4	68	8	4	B
50	40	16	735 798 810	0.129	60	88	43	82	3.0	69	8	4	B
63	50	16	735 798 811	0.187	75	102	56		3.0	72	9		A
75	65	16	735 798 812	0.298	89	122	66		3.6	80	10		A
90	80	16	735 798 813	0.377	105	138	78	133	4.3	81	12	4	B
110	100	16	735 798 814	0.630	125	158	100		5.3	81	13		C
140	125	16	735 798 816	0.847	155	188	127		6.7	90	16		C
160	150	16	735 798 817	1.200	175	212	151		7.7	93	17		C
200	200	16	735 798 819	1.900	232	268	203		9.6	102	22		C
225	200	16	735 798 820	2.000	235	268	203		10.8	102	22		C

35 79 88

Flange Adaptors, PN16, inch ANSI jointing face serrated, PVDF-Standard

K

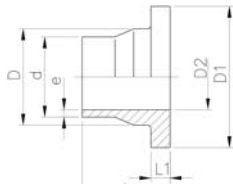

PF 2 35 190

Model:

- Other dimensions identical with metric version

d [mm]	d [inch]	PN	Code	kg	D [mm]	D1 [mm]	D2 [mm]	e [mm]	L [mm]	L1 [mm]
25	¾	16	735 798 857	0.043	32	54	20	1.9	56	7
32	1	16	735 798 858	0.063	40	63	26	2.4	58	7
40	1 ¼	16	735 798 859	0.089	49	73	34	2.4	68	8
50	1 ½	16	735 798 860	0.123	60	82	43	3.0	69	8
90	3	16	735 798 861	0.362	105	133	78	4.3	81	12

Flange Adaptors, PN10, jointing face serrated, PVDF-Standard

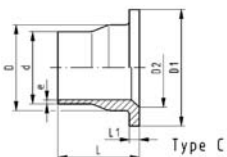
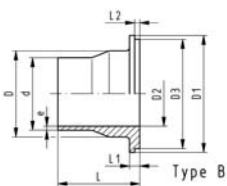
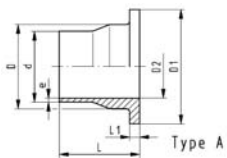

PF 2 35 190

d [mm]	DN [mm]	PN	Code	kg	D [mm]	D1 [mm]	D2 [mm]	D3 [mm]	e [mm]	L [mm]	L1 [mm]	L2 [mm]	Type
90	80	10	735 798 863	0.350	105	138	78	133	2.8	81	12	4	B
110	100	10	735 798 864	0.450	125	158	100		3.4	81	13		A
125	100	10	735 798 865	0.480	132	158	114		3.9	82	14		A
140	125	10	735 798 866	0.710	155	188	127		4.3	90	16		A
160	150	10	735 798 867	1.000	175	212	151		4.9	93	17		C
200	200	10	735 798 869	1.700	232	268	203		6.2	102	22		C
225	200	10	735 798 870	1.600	235	268	203		6.9	102	22		A

27 70 04
27 70 05

Backing Flanges, PP-V for Butt Fusion Systems metric

G

Model:

- Modern full-plastic flange PP-GF (30 % glass-fibre reinforced)
- With V-groove which applies force evenly on collar
- With integrated bolt retainers as an assembly aid
- Connecting dimension: ISO 7005 PN 10, EN 1092 PN 10, DIN 2501 PN 10, BS 4504 PN 10

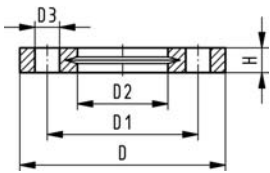
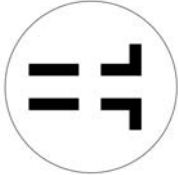

1) Suitable for socket- and butt fusion systems (no pictograph on flange)

d [mm]	Inch	DN [mm]	PN	Code	SP	kg	D [mm]	D1 [mm]	D2 [mm]	D3 [mm]	H [mm]	AL	SC
20		15	16	727 700 406	-	0.080	95	65	28	14	16	4	M12
25		20	16	727 700 407	-	0.100	105	75	34	14	17	4	M12
32		25	16	727 700 408	-	0.140	115	85	42	14	18	4	M12
40		32	16	727 700 409	-	0.220	140	100	51	18	20	4	M16
50		40	16	727 700 410	-	0.210	150	110	62	18	22	4	M16
63		50	16	727 700 411	-	0.380	165	125	78	18	24	4	M16
75		65	16	727 700 412	-	0.480	185	145	92	18	26	4	M16
90		80	16	727 700 513	-	0.520	200	160	108	18	27	8	M16
110		100	16	727 700 514	-	0.680	220	180	128	18	28	8	M16
125		100	16	727 700 515	-	0.760	220	180	135	18	28	8	M16
140		125	16	727 700 516	-	0.800	250	210	158	18	30	8	M16
160	6	150	16	727 700 517	-	1.200	285	241	178	22	32	8	M20
180		150	16	727 700 518	-	1.200	285	240	188	22	32	8	M20
200	8	200	16	727 700 519	-	1.400	340	295	235	22	34	8	M20
225	9	200	16	727 700 520	-	1.400	340	295	238	22	34	8	M20
250		250	16	727 700 521	-	1.700	395	350	288	22	38	12	M20
280		250	16	727 700 522	-	1.700	395	350	294	22	38	12	M20
315		300	16	727 700 523	-	2.400	445	400	338	22	42	12	M20

PF 2 34 238

27 70 02
27 70 03

Backing Flanges, PP/Steel for Butt Fusion Systems metric

G

Model:

- Material: PP (30 % glass-fibre reinforced) with steel ring
- Connecting dimensions: ISO 7005 / EN 1092 / DIN 2501 PN10 / BS4504

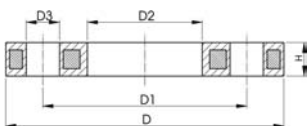

d [mm]	DN [mm]	PN	Code	D [mm]	D1 [mm]	D2 [mm]	D3 [mm]	H [mm]	AL	SC
20	15	16	727 700 206	95	65	28	14	12	4	M12
25	20	16	727 700 207	105	75	34	14	12	4	M12
32	25	16	727 700 208	115	85	42	14	16	4	M12
40	32	16	727 700 209	140	100	51	18	16	4	M16
50	40	16	727 700 210	150	110	62	18	18	4	M16
63	50	16	727 700 211	165	125	78	18	18	4	M16
75	65	16	727 700 212	185	145	92	18	18	4	M16
90	80	16	727 700 313	200	160	108	18	20	8	M16
110	100	16	727 700 314	220	180	128	18	20	8	M16
125	100	16	727 700 315	220	180	135	18	20	8	M16
140	125	16	727 700 316	250	210	158	18	24	8	M16
160	150	16	727 700 317	285	240	178	22	24	8	M20
180	150	16	727 700 318	285	240	188	22	24	8	M20
200	200	16	727 700 319	340	295	235	22	27	8	M20
225	200	16	727 700 320	340	295	238	22	27	8	M20
250	250	16	727 700 321	395	350	288	22	30	12	M20
280	250	16	727 700 322	395	350	294	22	30	12	M20
315	300	16	727 700 323	445	400	338	22	34	12	M20
355	350	16	727 700 324	515	460	376	23	40	16	M20
400	400	16	727 700 325	574	515	430	26	40	16	M24

PF 2 34 238

27 70 14
27 70 15

Backing Flanges, PP-V for Butt Fusion Systems Inch/ANSI

G

Model:

- Modern full-plastic flange PP-GF (30 % glass-fibre reinforced)
- With V-groove which applies force evenly on collar
- With integrated bolt-fixing as an assembly aid
- Connection dimensions according to ANSI B 16.5, ASTM D 4024; bolt circle class 150

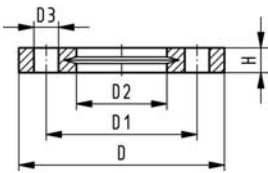
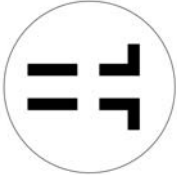

PF 2 34 238

¹⁾ Suitable for socket- and butt fusion systems (no pictograph on flange)

Inch	DN [mm]	PN	Code	kg	D [mm]	D1 [mm]	D2 [mm]	D3 [mm]	H [mm]	AL	SC
1/2	15	16	727 701 406	0.080	95	60	28	16	16	4	M12
3/4	20	16	727 701 407	0.100	105	70	34	16	17	4	M12
1	25	16	727 701 408	0.140	115	79	42	16	18	4	M12
1 1/4	32	16	727 701 409	0.220	140	89	51	16	20	4	M16
1 1/2	40	16	727 701 410	0.210	150	98	62	16	22	4	M16
2	50	16	727 701 411	0.380	165	121	78	19	24	4	M16
2 1/2	65	16	727 701 412	0.480	185	140	92	19	26	4	M16
3	80	16	727 701 513	0.520	200	152	108	19	27	4	M16
4	100	16	727 701 514	0.680	229	190	128	19	28	8	M16
6	150	16	727 700 517	1.200	285	241	178	22	32	8	M20
8	200	16	727 700 519	1.400	340	295	235	22	34	8	M20
9	200	16	727 700 520	1.400	340	295	238	22	34	8	M20
10	250	16	727 701 521	1.800	406	362	288	26	38	12	M20
10	250	16	727 701 522	1.700	406	362	294	26	38	12	M20
12	300	16	727 701 523	2.400	483	432	338	26	42	12	M20

27 70 12

Backing Flanges, PP/Steel for Butt Fusion Systems Inch/ANSI

G

Model:

- For butt fusion systems
- Material: PP (30 % glass-fibre reinforced) with steel ring
- Bolt circle diameter and bolt holes: ANSI B16.5

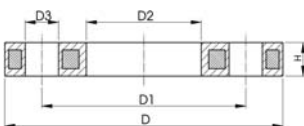

PF 2 34 238

Inch	DN [mm]	d [mm]	PN	Code	SP	kg	D [mm]	D1 [mm]	D2 [mm]	D3 [mm]	H [mm]	AL
1/2	15	20	16	727 701 206	-	0.210	95	60	28	16	12	4
3/4	20	25	16	727 701 207	-	0.250	105	70	34	16	12	4
1	25	32	16	727 701 208	-	0.420	115	79	42	16	16	4
1 1/4	32	40	16	727 701 209	-	0.670	140	89	51	16	16	4
1 1/2	40	50	16	727 701 210	-	0.860	150	98	62	16	18	4
2	50	63	16	727 701 211	-	0.930	165	121	78	19	18	4
2 1/2	65	75	16	727 701 212	-	1.340	185	140	92	19	18	4
3	80	90	16	727 701 313			200	152	108	19	20	4
4	100	110	16	727 701 314			229	190	128	19	20	8
6	150	160	16	727 701 317			285	241	178	22	24	8
(8)	200	200	16	727 701 319			340	298	235	22	27	8
8	200	225	16	727 701 320			340	298	238	22	27	8

SYGEF® Standard

Backing Flange PVDF/Steel for Butt Fusion Systems metric

Model:

- Material: PVDF (blue) coated steel
- Bolt circle diameter and bolt holes: ANSI B16.5 #150

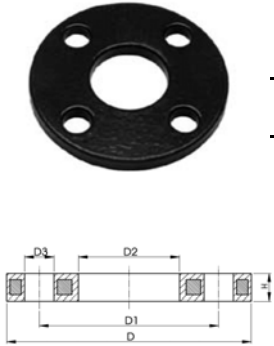

d	DN	Inch	Code	PN	KG	D (mm)	D1 (mm)	D2 (mm)	D3 (mm)	H (mm)	AL
20	15	¾	155 701 806	16	0.23	89	60	28	16	7	4
25	20	¾	155 701 807	16	0.34	98	70	34	16	7	4
32	25	1	155 701 808	16	0.34	108	79	42	16	7	4
40	32	1¼	155 701 809	16	0.51	117	89	51	16	8	4
50	40	1½	155 701 810	16	0.60	127	98	62	16	8	4
63	50	2	155 701 811	16	0.97	152	121	78	19	10	4
75	65	2½	155 701 812	16	1.34	178	140	92	19	10	4
90	80	3	155 701 813	16	1.45	190	152	110	19	10	4
110	100	4	155 701 814	16	2.07	229	190	133	19	10	8
160	150	6	155 701 917	16	3.34	279	241	179	22	13	8
200	200	8	155 701 919	16	5.96	343	298	236	22	16	8
225	200	8/9	155 701 920	16	5.75	343	298	239	22	16	8
250	225	10	155 701 921	10	7.62	406	362	288	22	22	12
315	300	12	155 701 923	10	18.18	483	432	338	25	25	12

SYGEF Plus Gasket

Model:

- TFM (tetrafluoroethylene) coated EPDM
- Self-centering design
- Multiple use gasket
- Specially cleaned & double-bagged
- Compatible with ANSI, ISO/DIN & JIS Flange Adaptors
- Must be used with Steel Backing Flange (not for use with PP-V Flange)

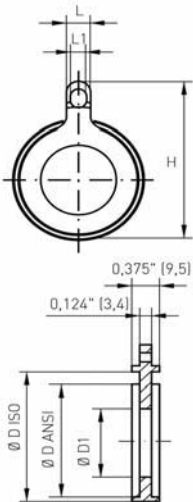

d	DN	Inch	Code	H	D ISO (mm)	D ANSI (inch)	L (mm)	L1 (mm)	D1 (mm)	Torque (Nm)
25	20	¾	731 400 753	76	58	2.13	20	13	23	9
32	25	1	731 400 755	91	68	2.48	25	16	30	10
40	32	1¼	731 400 757	101	78	2.87	25	16	38	20
50	40	1½	731 400 759	110	88	3.23	25	16	46	25
63	50	2	731 400 760	128	102	4.02	25	16	59	30
75	65	2½	731 400 761	148	122	4.80	25	16	67	35
90	80	3	731 400 763	161	138	5.24	25	16	80	40
110	100	4	731 400 764	189	158	6.22	25	16	98	45
140	125	5	731 400 666	219	188	7.40	30	20	129	50
160	150	6	731 400 667	244	212	8.35	30	20	148	60
200	200	8	731 400 669	300	268	10.55	30	20	185	75
225	200	8/9	731 400 670	300	268	10.55	30	20	209	75
250	225	10	731 400 671	369	320	12.60	35	22	250	80

EPDM 48 44 01
FPM 49 44 01

Flange Gaskets metric

A

Model:

- G-ST-P/K Profil
- Hardness: 70° Shore **EPDM**, 75° Shore **FPM**
- For Flange Adaptors
- For flange adaptors only in combination with butterfly valves

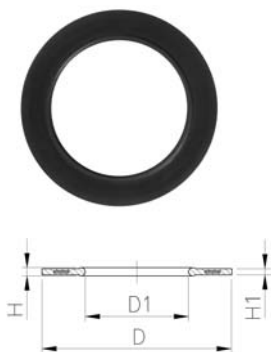

d [mm]	EPDM Code	FPM Code	kg	D [mm]	D1 [mm]	H [mm]	H1 [mm]
16	748 440 100	749 440 100	0.007	46	16	4	3
20	748 440 101	749 440 101	0.008	51	20	4	3
25	748 440 102	749 440 102	0.011	61	25	4	3
32	748 440 103	749 440 103	0.014	71	32	4	3
40	748 440 104	749 440 104	0.020	82	40	4	3
50	748 440 105	749 440 105	0.021	92	50	4	3
63	748 440 106	749 440 106	0.040	107	63	5	4
75	748 440 107	749 440 107	0.054	127	75	5	4
90	748 440 108	749 440 108	0.060	142	90	5	4
110	748 440 109	749 440 109	0.083	162	110	6	5
125	748 440 110	749 440 110	0.154	192	125	6	5
140	748 440 111	749 440 111	0.115	192	140	6	5
160	748 440 112	749 440 112	0.149	218	160	8	6
200	748 440 114	749 440 114	0.257	273	200	8	6
225	748 440 115	749 440 115	0.177	273	225	8	6
250	748 440 116	749 440 116	0.400	328	250	8	6
280	748 440 117	749 440 117	0.220	328	280	8	6
315	748 440 118	749 440 118	0.326	378	315	8	6
355	748 440 119	749 440 119	0.400	438	355	10	7
400	748 440 120	749 440 120	0.500	489	400	10	7

PF 2 30 162

Fittings for Socket Fusion

35 10 01

Elbow 90°, PN 16, PVDF-Standard

J

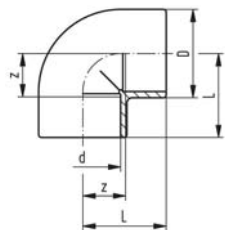

PF 2 35 189

d [mm]	PN	Code	kg	kg/m	D [mm]	L [mm]	z [mm]
16	16	735 100 105	0.029	0.029	26	25	12
20	16	735 100 106	0.026	0.026	27	28	14
25	16	735 100 107	0.038	0.038	32	32	16
32	16	735 100 108	0.065	0.065	40	38	20
40	16	735 100 109	0.104	0.104	49	44	24
50	16	735 100 110	0.164	0.164	60	51	28
63	16	735 100 111	0.284	0.284	75	62	35

35 15 01

Elbows 45° ; PN 16, PVDF-Standard

J

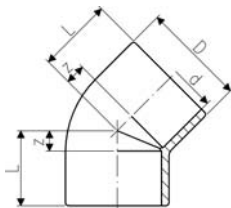

PF 2 35 189

d [mm]	PN	Code	kg	kg/m	D [mm]	L [mm]	z [mm]
16	16	735 150 105	0.017	0.017	23	20	7
20	16	735 150 106	0.020	0.020	27	21	7
25	16	735 150 107	0.030	0.030	32	24	8
32	16	735 150 108	0.051	0.051	40	28	10
40	16	735 150 109	0.083	0.083	49	33	13
50	16	735 150 110	0.123	0.123	60	36	13
63	16	735 150 111	0.211	0.211	75	43	16

35 20 01

T 90° equal ; PN 16, PVDF-Standard

J

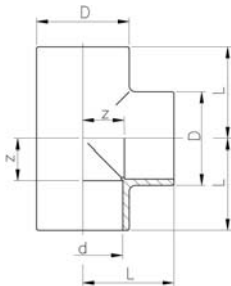

PF 2 35 189

d [mm]	PN	Code	kg	kg/m	D [mm]	L [mm]	z [mm]
16	16	735 200 105	0.039	0.039	26	25	12
20	16	735 200 106	0.035	0.035	27	28	14
25	16	735 200 107	0.050	0.050	32	32	16
32	16	735 200 108	0.085	0.085	40	38	20
40	16	735 200 109	0.135	0.135	49	44	24
50	16	735 200 110	0.208	0.208	60	51	28
63	16	735 200 111	0.360	0.360	75	62	35

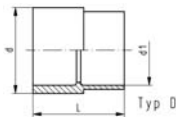
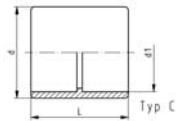
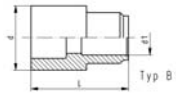
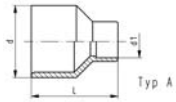

d - d1 [mm]	PN	Code	kg	kg/m	L [mm]	z [mm]	Type
20 - 16	16	735 910 334	0.017	0.017	35	22	B
25 - 20	16	735 910 337	0.017	0.017	37	23	A
32 - 20	16	735 910 342	0.022	0.022	43	29	A
32 - 25	16	735 910 341	0.023	0.023	39	23	C
40 - 20	16	735 910 348	0.033	0.033	48	34	A
40 - 25	16	735 910 347	0.037	0.037	48	32	A
40 - 32	16	735 910 346	0.037	0.037	43	25	C
50 - 20	16	735 910 355	0.059	0.059	54	40	A
50 - 25	16	735 910 354	0.058	0.058	54	38	A
50 - 32	16	735 910 353	0.062	0.062	54	36	A
50 - 40	16	735 910 352	0.063	0.063	48	28	C
63 - 20	16	735 910 362	0.103	0.103	64	50	A
63 - 25	16	735 910 361	0.105	0.105	64	48	A
63 - 32	16	735 910 360	0.108	0.108	64	46	A
63 - 40	16	735 910 359	0.117	0.117	64	44	A
63 - 50	16	735 910 358	0.105	0.105	54	31	D

Overview about functionality

Code	PN	L	Main function			Additional functions												
			Spigot d	- Socket d ₁	L	Z	Reduction Socket - Socket			Reduction Spigot - Spigot			Reduktion Socket - Spigot					
			d	d ₁	L	Z	d	d ₁	L	Z	d	d ₁	L	Z	d	d ₁	L	Z
735 910 334	16	35	20	- 16	35	22												
735 910 337	16	37	25	- 20	37	23												
735 910 342	16	43	32	- 20	43	29	25	- 20	43	13								
735 910 341	16	39	32	- 25	39	23												
735 910 348	16	48	40	- 20	48	34	32	- 20	48	16								
735 910 347	16	48	40	- 25	48	32	32	- 25	48	14	40	- 32	48	48				
735 910 346	16	43	40	- 32	43	25												
735 910 355	16	54	50	- 20	54	40	40	- 20	54	20								
735 910 354	16	54	50	- 25	54	38	40	- 25	54	18	50	- 32	54	54	40	- 32	54	34
735 910 353	16	54	50	- 32	54	36	40	- 32	54	16	50	- 40	54	54				
735 910 352	16	48	50	- 40	48	28												
735 910 362	16	64	63	- 20	64	50	50	- 20	64	27								
735 910 361	16	64	63	- 25	64	48	50	- 25	64	25	63	- 32	64	64	50	- 32	64	41
735 910 360	16	64	63	- 32	64	46	50	- 32	64	23	63	- 40	64	64	50	- 40	64	41
735 910 359	16	64	63	- 40	64	44	50	- 40	64	21	63	- 50	64	64				
735 910 358	16	54	63	- 50	54	31												

Please note: Illustration of the functions not inevitably conform to respective type!

35 91 01

Socket equal, PN16, PVDF-Standard

J

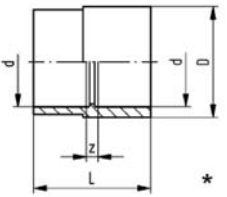
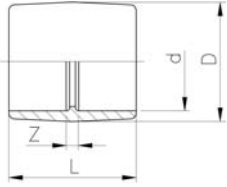

PF 2 35 189

d [mm]	PN	Code	kg	kg/m	D [mm]	L [mm]	z [mm]
16	16	735 910 105	0.020	0.020	26	33	7
20	16	735 910 106	0.016	0.016	27	35	7
25	16	735 910 107	0.023	0.023	32	39	7
32	16	735 910 108	0.037	0.037	40	43	7
*40	16	735 910 109	0.063	0.063	50	48	8
*50	16	735 910 110	0.105	0.105	63	54	8
63	16	735 910 111	0.146	0.146	75	62	8

35 96 01

Caps ; PN 16, PVDF-Standard

J

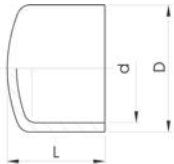

PF 2 35 189

d [mm]	PN	Code	kg	kg/m	D [mm]	L [mm]
16	16	735 960 105	0.013	0.013	25	24
20	16	735 960 106	0.011	0.011	27	23
25	16	735 960 107	0.017	0.017	32	26
32	16	735 960 108	0.028	0.028	40	30
40	16	735 960 109	0.045	0.045	49	34
50	16	735 960 110	0.073	0.073	60	39
63	16	735 960 111	0.128	0.128	75	46

Unions for Socket Fusion

35 51 01

Union (FPM black), PN16, PVDF-Standard

J

- Supplied with: O-Ring No. 49 41 00 FPM (e.g. Viton A®)
- Please see installation instruction



PF 2 35 191

d [mm]	PN	Code	GP	kg	kg/m	D [mm]	G [inch]	L1 [mm]	L2 [mm]	z1 [mm]	z [mm]	
16	16	735 510 105	140	0.025	0.025	35	3/4	18	24	5	11	
20	16	735 510 106	70	0.064	0.064	45	1	19	26	5	12	
25	16	735 510 107	50	0.101	0.101	55	1 1/4	21	28	5	12	
32	16	735 510 108	20	0.132	0.132	62	1 1/2	23	30	5	12	
40	16	735 510 109	20	0.219	0.219	75	2	25	34	5	14	
50	16	735 510 110	30	0.289	0.289	84	2 1/4	28	39	5	16	
63	16	735 510 111	12	0.496	0.496	101	2 3/4	32	47	5	20	

35 60 01

Union end, PN 16, PVDF-Standard

J

Model:

- Suitable for SYGEF® Standard Union Socket Fusion
- Suitable for Diaphragm Valve Type 314
- Suitable for Vortex Sensor

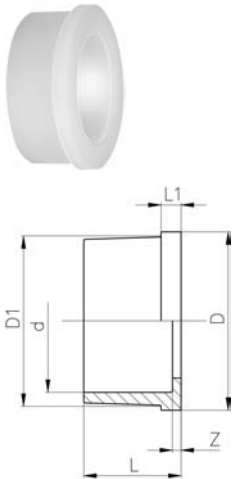

PF 2 35 191

d [mm]	PN	Code	kg	kg/m	D [mm]	D1 [mm]	L [mm]	L1 [mm]	z [mm]	
16	16	735 600 105	0.006	0.006	24	22	18	4	5	
20	16	735 600 106	0.011	0.011	30	28	19	5	5	
25	16	735 600 107	0.022	0.022	39	36	21	5	5	
32	16	735 600 108	0.026	0.026	45	42	23	6	5	
40	16	735 600 109	0.046	0.046	57	53	25	6	5	
50	16	735 600 110	0.054	0.054	63	59	28	7	5	
63	16	735 600 111	0.079	0.079	78	74	32	7	5	

Blanking Union End

d [mm]	d [inch]	PN	DN [mm]	Code	SP	GP	kg	kg/m	A [mm]	B [mm]	C [inch]	D [mm]	
20		232	0	175 482 101	-	-	0.007	0.007					
25		232	0	175 482 102	-	-	0.015	0.015	1	1	1	0	
32		232	0	175 482 103	-	-	0.025	0.025	2	1	1	0	
50		232	0	175 482 105	-	-	0.060	0.060					
63		232	0	175 482 106	-	-	0.110	0.110					

PF 2 65 434

24 60 07

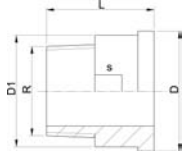
Union Ends, Stainless Steel 1.4404 (316L)**R****A****Model:**

- Taper male thread R

R [inch]	PN	Code	SP	GP	kg	D [mm]	D1 [mm]	L [mm]	s [mm]	
3/8	16	724 600 705	-	-	0.050	24	22	30	19	
1/2	16	724 600 706	-	-	0.090	30	28	34	24	
3/4	16	724 600 707	-	-	0.120	39	36	36	32	
1	16	724 600 708	-	-	0.190	45	42	40	37	
1 1/4	16	724 600 709	-	-	0.350	57	53	46	48	
1 1/2	16	724 600 710	-	-	0.400	63	59	48	54	
2	16	724 600 711	-	-	0.660	78	74	55	69	

PF 2 30 153

24 60 06

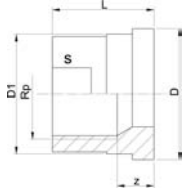
Union Ends, Stainless Steel 1.4404 (316L)**Rp****A****Model:**

- Parallel female thread Rp

Rp [inch]	PN	Code	SP	GP	kg	z [mm]	D [mm]	D1 [mm]	L [mm]	s [mm]	
3/8	16	724 600 655	-	-	0.030	9	24	22	19	19	
1/2	16	724 600 656	-	-	0.060	11	30	28	24	24	
3/4	16	724 600 657	-	-	0.100	11	39	36	26	29	
1	16	724 600 658	-	-	0.140	12	45	42	29	36	
1 1/4	16	724 600 659	-	-	0.230	14	57	53	33	45	
1 1/2	16	724 600 660	-	-	0.320	15	63	59	34	54	
2	16	724 600 661	-	-	0.450	15	78	74	39	63	

PF 2 30 153

24 60 55

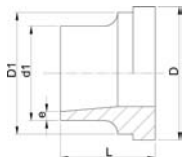
Union Ends, Stainless Steel 1.4404 (316L)**Welding End****A**

d [mm]	d1 [mm]	PN	Code	SP	GP	kg	D [mm]	D1 [mm]	L [mm]	e [mm]	
16	17	16	724 605 505	-	-	0.030	24	22	18	1.6	
20	21	16	724 605 506	-	-	0.050	30	28	22	2.0	
25	26	16	724 605 507	-	-	0.080	39	36	23	2.0	
32	33	16	724 605 508	-	-	0.110	45	42	26	2.0	
40	42	16	724 605 509	-	-	0.190	57	53	26	2.0	
50	48	16	724 605 510	-	-	0.220	63	59	28	2.0	
63	60	16	724 605 511	-	-	0.370	78	74	32	2.6	

PF 2 30 153

35 69 04

Union nut, PN16, PVDF-Standard

J

- d75, d90 and d110 with buttress shaped thread

Note:

- For the dimensions d75-110 please see instructions for the installation

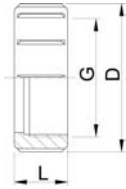

PF 2 35 191

Socket Fusion d [mm]	Butt Fusion d [mm]	PN	Code	kg	kg/m	D [mm]	G [inch]	L [mm]	
16	16	16	735 690 405	0.013	0.013	35	3/4	21	
20	20	16	735 690 406	0.023	0.023	45	1	22	
25	25	16	735 690 407	0.047	0.047	55	1 1/4	24	
32	32	16	735 690 408	0.048	0.048	62	1 1/2	26	
40	40	16	735 690 409	0.097	0.097	75	2	29	
50	50	16	735 690 410	0.146	0.146	84	2 1/4	33	
63	63	16	735 690 411	0.244	0.244	101	2 3/4	35	

24 69 01

Union nut stainless steel 1.4404 (316L)

A

* Octagon union nut

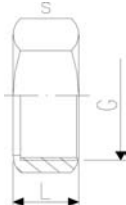

PF 2 30 153

d [mm]	PN	Code	SP	GP	kg	kg/m	L [mm]	G [inch]	s [mm]	
16	16	724 690 105	-	-	0.060	0.060	19	3/4	32	
20	16	724 690 106	-	-	0.110	0.110	21	1	41	
25	16	724 690 107	-	-	0.100	0.100	23	1 1/4	46	
32	16	724 690 108	-	-	0.170	0.170	24	1 1/2	55	
*40	16	724 690 109	-	-	0.240	0.240	27	2	68	
*50	16	724 690 110	-	-	0.300	0.300	31	2 1/4	74	
*63	16	724 690 111	-	-	0.390	0.390	35	2 3/4	88	

35 64 01

Union bush, PN 16, PVDF-Standard

J

Model:

- Suitable for SYGEF® Standard Union Socket Fusion

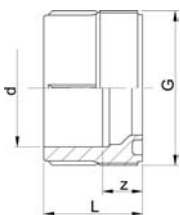

PF 2 35 191

d [mm]	PN	Code	kg	kg/m	G [inch]	L [mm]	z [mm]	
16	16	735 640 105	0.011	0.011	3/4	24	11	
20	16	735 640 106	0.019	0.019	1	26	12	
25	16	735 640 107	0.031	0.031	1 1/4	28	12	
32	16	735 640 108	0.042	0.042	1 1/2	30	12	
40	16	735 640 109	0.069	0.069	2	34	14	
50	16	735 640 110	0.091	0.091	2 1/4	39	16	
63	16	735 640 111	0.161	0.161	2 3/4	47	20	

EPDM 48 41 00
FPM 49 41 00

O-Ring Gaskets

A

Model:

- For unions
- Hardness approx. 65° Shore
- EPDM minimum temperature -40°C
- FPM minimum temperature -15°C

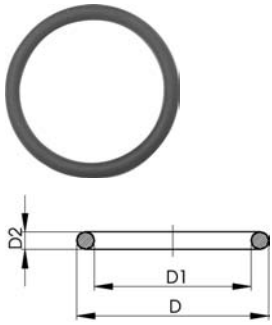

d [mm]	DN [mm]	EPDM Code	FPM Code	SP	GP	kg	kg/m	D [mm]	D1 [mm]	D2 [mm]
10-12	8	748 410 004	749 410 004	-	-	0.002	0.002	18	12	3
16	10	748 410 005	749 410 005	-	-	0.002	0.002	21	16	3
20	15	748 410 006	749 410 006	-	-	0.002	0.002	27	20	4
25	20	748 410 007	749 410 007	100	1400	0.002	0.002	35	28	4
32	25	748 410 008	749 410 008	100	-	0.002	0.002	40	33	4
40	32	748 410 009	749 410 009	-	-	0.006	0.006	51	41	5
50	40	748 410 010	749 410 010	-	-	0.007	0.007	58	47	5
63	50	748 410 011	749 410 011	100	3500	0.010	0.010	70	60	5
75	65	748 410 014	749 410 014	100	600	0.012	0.012	93	82	5
90	80	748 410 015	749 410 015	100	600	0.015	0.015	112	101	5
110	100	748 410 016	749 410 016	50	200	0.031	0.031	134	120	7

PF 2 30 162



O-Ring Gaskets

Model:

- For unions
- Hardness approx. 75° Shore
- FFPM minimum temperature -20°C

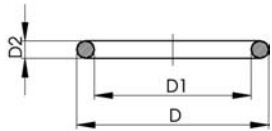

d [mm]	DN [mm]	FFPM Code	D [mm]	D1 [mm]	D2 [mm]
20	15	700 245 481	27	20	4
25	20	700 245 482	35	28	4
32	25	700 245 483	40	33	4
40	32	700 245 484	51	41	5
50	40	700 245 485	58	47	5
63	50	700 245 486	70	60	5

PF 2 30 1

Transition Fittings for Socket Fusion

35 91 02

Adaptor Socket, female thread - Rp, PN 16, PVDF-Standard

J

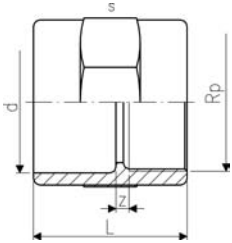

PF 2 35 191

Model:

- With socket fusion end and parallel female thread
- Connection to plastic thread only
- Do not use thread sealing pastes that are harmful to PVDF
- Avoid stresses when installing and large changes in temperature

d [mm]	Rp [inch]	PN	Code	kg	kg/m	L [mm]	s [mm]	z [mm]
20	½	16	735 910 206	0.030	0.030	34	32	5
25	¾	16	735 910 207	0.037	0.037	38	36	6
32	1	16	735 910 208	0.067	0.067	43	46	7
40	1 ¼	16	735 910 209	0.100	0.100	47	55	7
50	1 ½	16	735 910 210	0.135	0.135	54	65	9
63	2	16	735 910 211	0.217	0.217	62	80	9

35 91 42

Adaptor Socket, female thread - NPT, PN 16, PVDF-Standard

J

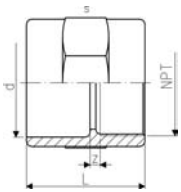

PF 2 35 191

Model:

- With socket fusion end and taper female thread
- Connection to plastic thread only
- Do not use thread sealing pastes that are harmful to PVDF
- Avoid stresses when installing and large changes in temperature

d [mm]	NPT [inch]	PN	Code	kg	kg/m	L [mm]	s [mm]	z [mm]
16	⅜	16	735 914 205	0.016	0.016	29	27	3
20	½	16	735 914 206	0.030	0.030	34	32	5
25	¾	16	735 914 207	0.036	0.036	38	36	6
32	1	16	735 914 208	0.067	0.067	43	46	7
40	1 ¼	16	735 914 209	0.100	0.100	47	55	7
50	1 ½	16	735 914 210	0.140	0.140	54	65	9
63	2	16	735 914 211	0.220	0.220	62	80	9

35 91 05

Adaptor Nipple, male thread - R, PN 16, PVDF-Standard

J

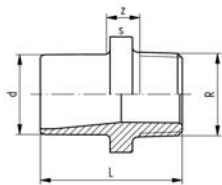

PF 2 35 191

Model:

- With socket fusion spigot metric and BSP tapered male thread
- Connection to plastic thread only
- Do not use thread sealing pastes that are harmful to PVDF
- Avoid stresses when installing and large changes in temperature

d [mm]	R [inch]	PN	Code	kg	kg/m	L [mm]	s [mm]	z [mm]
16	⅜	16	735 910 505	0.015	0.015	37	27	12
20	½	16	735 910 506	0.025	0.025	53	32	25
25	¾	16	735 910 507	0.032	0.032	55	36	24
32	1	16	735 910 508	0.052	0.052	57	46	22
40	1 ¼	16	735 910 509	0.076	0.076	60	55	21
50	1 ½	16	735 910 510	0.112	0.112	63	65	19
63	2	16	735 910 511	0.163	0.163	69	75	18

35 91 45

Adaptor Nipple, male thread - NPT, PN 16, PVDF-Standard

J

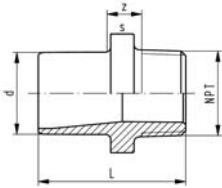

Model:

- With socket fusion spigot and taper male thread
- Connection to plastic thread only
- Do not use thread sealing pastes that are harmful to PVDF
- Avoid stresses when installing and large changes in temperature

d [mm]	NPT [inch]	PN	Code	kg	kg/m	L [mm]	s [mm]	z [mm]
16	3/8	16	735 914 505	0.014	0.014	37	27	12
20	1/2	16	735 914 506	0.025	0.025	53	32	25
25	3/4	16	735 914 507	0.033	0.033	55	36	24
32	1	16	735 914 508	0.052	0.052	57	46	22
40	1 1/4	16	735 914 509	0.076	0.076	60	55	21
50	1 1/2	16	735 914 510	0.114	0.114	63	65	19
63	2	16	735 914 511	0.164	0.164	69	75	18

PF 2 35 191

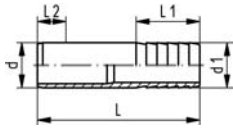

Hose Adapter, PN 16, PVDF-Standard

J

Model:

- With socket fusion spigot, PN 16

d - d1 [mm]	PN	Code	kg	kg/m	L [mm]	L1 [mm]	L2 [mm]	z [mm]
16 - 16	16	735 960 405	0.001	0.001	50	27	13	10
20 - 20	16	735 960 406	0.001	0.001	78	27	14	37
25 - 25	16	735 960 407	0.001	0.001	91	36	16	39
32 - 32	16	735 960 408	0.001	0.001	100	36	18	46
40 - 40	16	735 960 409	0.001	0.001	104	42	20	42
50 - 50	16	735 960 410	0.089	0.089	90	48	23	19
63 - 60	16	735 960 411	0.126	0.126	100	50	27	23

PF 2 35 191

Flange Adaptors, Flanges and Gaskets for Socket Fusion

Fixed Flanges, socket fusion Jointing face serrated, metric

J

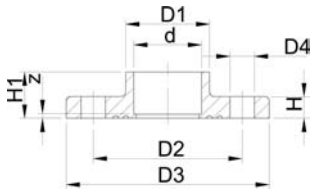

Model:

- With fusion socket metric
- Material: PVDF
- Flange drillings to: ISO / DIN

d [mm]	DN [mm]	Inch	PN	Code	SP	GP	kg	kg/m
20	15	1/2	16	735 740 106	-	-	0.137	0.137
25	20	3/4	16	735 740 107	-	-	0.185	0.185
32	25	1	16	735 740 108	-	-	0.255	0.255
40	32	1 1/4	16	735 740 109	-	-	0.402	0.402
50	40	1 1/2	16	735 740 110	-	-	0.486	0.486
63	50	2	16	735 740 111	-	-	0.551	0.551

d [mm]	D1 [mm]	D2 [mm]	D3 [mm]	D4 [mm]	H [mm]	H1 [mm]	AL	z [mm]
20	27	65	93	14	12	19	4	5
25	33	75	103	14	13	21	4	4
32	40	85	115	14	14	23	4	4
40	50	100	137	18	15	25	4	4
50	61	110	147	18	16	27	4	4
63	76	125	162	18	18	31	4	4

PF 2 35 446

Fixed Flanges, socket fusion Jointing face flat, metric

J

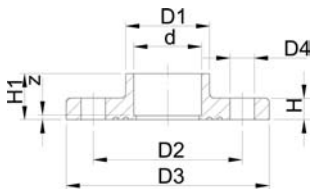

Model:

- With fusion socket metric
- Material: PVDF
- Flange drillings to: ISO / DIN

d [mm]	DN [mm]	Inch	PN	Code	SP	GP	kg	kg/m
20	15	11/2	16	735 730 106	-	-	0.137	0.137
25	20	13/4	16	735 730 107	-	-	0.185	0.185
32	25	1	16	735 730 108	-	-	0.255	0.255
40	32	1 1/4	16	735 730 109	-	-	0.355	0.355
50	40	1 1/2	16	735 730 110	-	-	0.486	0.486
63	50	2	16	735 730 111	-	-	0.653	0.653

d [mm]	D1 [mm]	D2 [mm]	D3 [mm]	D4 [mm]	H [mm]	H1 [mm]	AL	z [mm]
20	27	65	93	14	12	19	4	5
25	33	75	103	14	13	21	4	5
32	40	85	115	14	14	23	4	5
40	50	100	137	18	15	25	4	5
50	61	110	147	18	16	27	4	5
63	76	125	162	18	18	31	4	5

PF 2 35 446

35 81 01

Flange Adaptors with groove, PN 16, PVDF-Standard

J

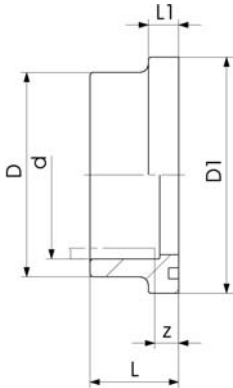

PF 2 35 191

Model:

- Jointing face: with O-ring groove
- Counterpart: Flange Adaptor metric or ANSI
- Gasket: O-ring EPDM No. 48 41 01, FPM No. 49 41 01

d [mm]	PN	Code	kg	kg/m	D [mm]	D1 [mm]	L [mm]	L1 [mm]	z [mm]
20	16	735 810 106	0.015	0.015	27	34	22	9	8
25	16	735 810 107	0.022	0.022	33	41	24	10	8
32	16	735 810 108	0.036	0.036	41	50	26	10	8
40	16	735 810 109	0.055	0.055	50	61	30	13	10
50	16	735 810 110	0.080	0.080	61	73	33	13	10
63	16	735 810 111	0.138	0.138	76	90	37	14	10

Flange Adaptor metric ; PN 16, PVDF-Standard

J

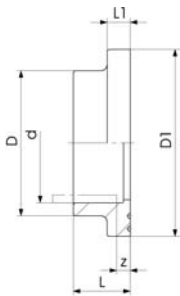

PF 2 35 191

Model:

- Increased face dimension metric
- Suitable for Flange Adaptor with groove
- Gasket: Profile Flange Gaskets **FPM** or **EPDM**
- Gasket: Flat Gasket **FPM** or **EPDM**

d [mm]	DN [mm]	PN	Code	kg	kg/m	D [mm]	D1 [mm]	L [mm]	L1 [mm]	z [mm]
20	15	16	735 790 206	0.020	0.020	27	45	19	6	3
25	20	16	735 790 207	0.037	0.037	33	58	21	7	3
32	25	16	735 790 208	0.051	0.051	41	68	23	7	3
40	32	16	735 790 209	0.073	0.073	50	78	25	8	3
50	40	16	735 790 210	0.095	0.095	61	88	28	8	3
63	50	16	735 790 211	0.142	0.142	76	102	32	9	3

Flange Adaptor, PN16, serrated, ANSI, PVDF-Standard

J

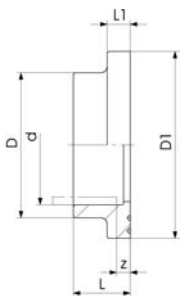

PF 2 35 191

Model:

- Suitable for Flange Adaptor with groove
- Face dimension ANSI
- Gasket: Flat Gasket **FPM** or **EPDM**
- Gasket: Profile Flange Gaskets **FPM** or **EPDM**
- Dimensions d20 and d63 are identical to metric version

d [mm]	d [inch]	PN	Code	GP	kg	kg/m	D [mm]	D1 [mm]	L [mm]	L1 [mm]	z [mm]
25	¾	16	735 790 257	-	0.037	0.037	33	54	21	7	3
32	1	16	735 790 258	-	0.051	0.051	41	63	23	7	3
40	1 ¼	16	735 790 259	-	0.073	0.073	50	73	25	8	3
50	1 ½	16	735 790 260	-	0.095	0.095	61	82	28	8	3

27 70 04
27 70 05

Backing Flanges, PP-V for Socket Systems metric

G

Model:

- Modern full-plastic flange PP-GF (30 % glass-fibre reinforced)
- With V-groove which applies force evenly on collar
- With integrated bolt retainers as an assembly aid
- Connecting dimension: ISO 7005 PN 10, EN 1092 PN 10, DIN 2501 PN 10, BS 4504 PN 10

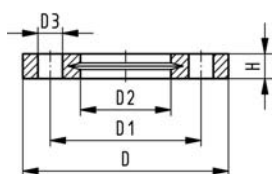

PF 2 34 238

¹⁾ Suitable for socket- and butt fusion systems (no pictograph on flange)

d [mm]	Inch	DN [mm]	PN	Code	kg	kg/m	D [mm]	D1 [mm]	D2 [mm]	D3 [mm]	H [mm]	AL	SC
'20		15	16	727 700 406	0.080	0.080	95	65	28	14	16	4	M12
'25		20	16	727 700 407	0.100	0.100	105	75	34	14	17	4	M12
'32		25	16	727 700 408	0.140	0.140	115	85	42	14	18	4	M12
'40		32	16	727 700 409	0.220	0.220	140	100	51	18	20	4	M16
'50		40	16	727 700 410	0.210	0.210	150	110	62	18	22	4	M16
'63		50	16	727 700 411	0.380	0.380	165	125	78	18	24	4	M16

27 70 02

Backing Flanges, PP/Steel for Socket Systems metric

G

Model:

- PP-GF (30% glass-fibre reinforced) with steel ring
- Connecting dimensions: ISO 7005, EN 1092, BS 4504, DIN 2501; bolt circle PN 10

* Connecting dimension: ISO 2536

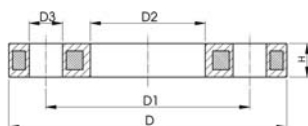

PF 2 34 238

d [mm]	DN [mm]	PN	Code	D [mm]	D1 [mm]	D2 [mm]	D3 [mm]	H [mm]	AL	SC
20	15	16	727 700 206	95	65	28	14	12	4	M12
25	20	16	727 700 207	105	75	34	14	12	4	M12
32	25	16	727 700 208	115	85	42	14	16	4	M12
40	32	16	727 700 209	140	100	51	18	16	4	M16
50	40	16	727 700 210	150	110	62	18	18	4	M16
63	50	16	727 700 211	165	125	78	18	18	4	M16

27 70 14
27 70 15

Backing Flanges, PP-V for Socket Systems Inch/ANSI

G

Model:

- Modern full-plastic flange PP-GF (30 % glass-fibre reinforced)
- With V-groove which applies force evenly on collar
- With integrated bolt-fixing as an assembly aid
- Connection dimensions according to ANSI B 16.5, ASTM D 4024; bolt circle class 150

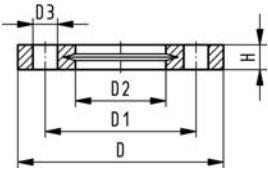

PF 2 34 238

¹⁾ Suitable for socket- and butt fusion systems (no pictograph on flange)

Inch	DN [mm]	PN	Code	kg	kg/m	D [mm]	D1 [mm]	D2 [mm]	D3 [mm]	H [mm]	AL	SC
1/2	15	16	727 701 406	0.080	0.080	95	60	28	16	16	4	M12
3/4	20	16	727 701 407	0.100	0.100	105	70	34	16	17	4	M12
1	25	16	727 701 408	0.140	0.140	115	79	42	16	18	4	M12
1 1/4	32	16	727 701 409	0.220	0.220	140	89	51	16	20	4	M16
1 1/2	40	16	727 701 410	0.210	0.210	150	98	62	16	22	4	M16
2	50	16	727 701 411	0.380	0.380	165	121	78	19	24	4	M16

27 70 12

Backing Flanges, PP/Steel for Socket Systems Inch/ANSI

G

Model:

- For socket systems
- For Flange Adaptors BS (ANSI)
- Material: PP (30 % glass-fibre reinforced) with steel ring
- Connecting dimension ANSI B 16.5 / ASTM D 4024
- DN100 and DN150: only for use with original metric flange adaptors

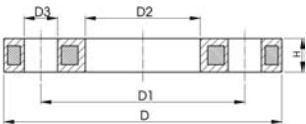

PF 2 34 238

Inch	DN [mm]	d [mm]	PN	Code	GP	kg	kg/m	D [mm]	D1 [mm]	D2 [mm]	D3 [mm]	H [mm]	AL
1/2	15	20	16	727 701 206	72	0.210	0.210	95	60	28	16	12	4
3/4	20	25	16	727 701 207	45	0.250	0.250	105	70	34	16	12	4
1	25	32	16	727 701 208	34	0.420	0.420	115	79	42	16	16	4
1 1/4	32	40	16	727 701 209	20	0.670	0.670	140	89	51	16	16	4
1 1/2	40	50	16	727 701 210	17	0.860	0.860	150	98	62	16	18	4
2	50	63	16	727 701 211	15	0.930	0.930	165	121	78	19	18	4

SYGEF® Standard

Backing Flange PVDF/Steel for Socket Fusion Systems metric

Model:

- Material: PVDF (blue) coated steel
- Bolt circle diameter and bolt holes: ANSI B16.5 #150

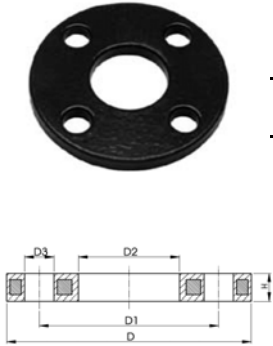

d	DN	Inch	Code	PN	KG	D (mm)	D1 (mm)	D2 (mm)	D3 (mm)	H (mm)	AL
20	15	¾	155 701 806	16	0.23	89	60	28	16	7	4
25	20	¾	155 701 807	16	0.34	98	70	34	16	7	4
32	25	1	155 701 808	16	0.34	108	79	42	16	7	4
40	32	1¼	155 701 809	16	0.51	117	89	51	16	8	4
50	40	1½	155 701 810	16	0.60	127	98	62	16	8	4
63	50	2	155 701 811	16	0.97	152	121	78	19	10	4
75	65	2½	155 701 812	16	1.34	178	140	92	19	10	4
90	80	3	155 701 813	16	1.45	190	152	110	19	10	4
110	100	4	155 701 814	16	2.07	229	190	133	19	10	8

SYGEF Plus Gasket

Model:

- TFM (tetrafluoroethylene) coated EPDM
- Self-centering design
- Multiple use gasket
- Specially cleaned & double-bagged
- Compatible with ANSI, ISO/DIN & JIS Flange Adaptors
- Must be used with Steel Backing Flange (not for use with PP-V Flange)

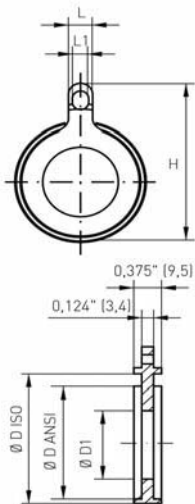

d	DN	Inch	Code	H	D ISO (mm)	D ANSI (inch)	L (mm)	L1 (mm)	D1 (mm)	Torque (Nm)
25	20	¾	731 400 753	76	58	2.13	20	13	23	9
32	25	1	731 400 755	91	68	2.48	25	16	30	10
40	32	1¼	731 400 757	101	78	2.87	25	16	38	20
50	40	1½	731 400 759	110	88	3.23	25	16	46	25
63	50	2	731 400 760	128	102	4.02	25	16	59	30
75	65	2½	731 400 761	148	122	4.80	25	16	67	35
90	80	3	731 400 763	161	138	5.24	25	16	80	40
110	100	4	731 400 764	189	158	6.22	25	16	98	45

EPDM 48 44 01
FPM 49 44 01

Flange Gaskets metric

A

Model:

- G-ST-P/K Profil
- Hardness: 70° Shore **EPDM**, 75° Shore **FPM**
- For Flange Adaptors
- For flange adaptors only in combination with butterfly valves

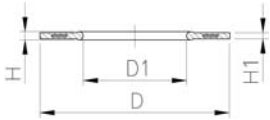

PF 2 30 162

d [mm]	EPDM Code	FPM Code	kg	kg/m	D [mm]	D1 [mm]	H [mm]	H1 [mm]	
16	748 440 100	749 440 100	0.007	0.007	46	16	4	3	
20	748 440 101	749 440 101	0.008	0.008	51	20	4	3	
25	748 440 102	749 440 102	0.011	0.011	61	25	4	3	
32	748 440 103	749 440 103	0.014	0.014	71	32	4	3	
40	748 440 104	749 440 104	0.020	0.020	82	40	4	3	
50	748 440 105	749 440 105	0.021	0.021	92	50	4	3	
63	748 440 106	749 440 106	0.040	0.040	107	63	5	4	

EPDM 48 41 01
FPM 49 41 01

O-Ring Gaskets

A

Model:

- For Flange Adaptors
- Hardness approx. 65° Shore

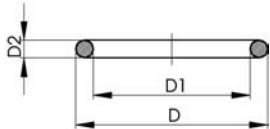

PF 2 31 800

d [mm]	DN [mm]	EPDM Code	FPM Code	SP	GP	kg	kg/m	D [mm]	D1 [mm]	D2 [mm]	
16	10	748 410 000	749 410 000	-	-	0.002	0.002	26	19	4	
20	15	748 410 001	749 410 001	100	-	0.002	0.002	31	23	4	
25	20	748 410 007	749 410 007	100	1400	0.002	0.002	35	28	4	
32	25	748 410 002	749 410 002	100	-	0.003	0.003	43	36	4	
40	32	748 410 003	749 410 003	-	-	0.007	0.007	55	44	5	
50	40	748 410 012	749 410 012	100	1000	0.008	0.008	64	53	5	
63	50	748 410 013	749 410 013	100	600	0.011	0.011	80	69	5	

Ball valves

SYGEF® standard Ball valve type 546 PVDF With mounting inserts With butt fusion spigots metric

J



DN10/15 - 50

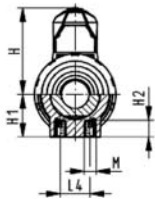
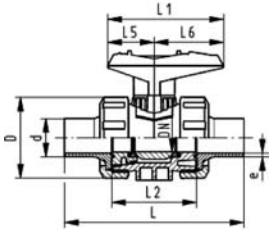

Model:

- For easy installation and removal
- z-dimension, valve end and valve nut are **not compatible** with type 346 (DN10/15-50) resp. type 370 (DN65-100)
- Ball seals PTFE
- Integrated stainless steel mounting inserts

Option:

- Individual configuration of the valve (see form)
- Multifunctional module with integrated limit switches
- Pneumatic or electric actuators from +GF+

d [mm]	DN [mm]	PN	kv-value ($\Delta p=1$ bar) [l/min]	FPM Code	kg
20	15	16	185	175 546 272	0.205
25	20	16	350	175 546 273	0.310
32	25	16	700	175 546 274	0.460
40	32	16	1000	175 546 275	0.780
50	40	16	1600	175 546 276	1.110
63	50	16	3100	175 546 277	2.150

d [mm]	D [mm]	H [mm]	H1 [mm]	H2 [mm]	L [mm]	L1 [mm]	L2 [mm]	L4 [mm]	L5 [mm]	L6 [mm]	M	e [mm]
20	50	57	27	12	130	77	56	25	32	45	M6	1,9
25	58	67	30	12	143	97	65	25	39	58	M6	1,9
32	68	73	36	12	150	97	71	25	39	58	M6	2,4
40	84	90	44	15	171	128	85	45	54	74	M8	2,4
50	97	97	51	15	191	128	89	45	54	74	M8	3
63	124	116	64	15	220	152	101	45	66	87	M8	3

PF 2 35 540



DN10/15 - 50

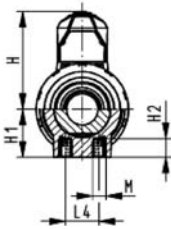
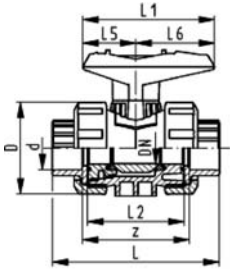

SYGEF® standard Ball valve type 546 PVDF With mounting inserts With fusion sockets metric

J

Model:

- For easy installation and removal
- z-dimension, valve end and valve nut are **not compatible** with type 346 (DN10/15-50) resp. type 370 (DN65-100)
- Ball seals PTFE
- Integrated stainless steel mounting inserts

Option:

- Individual configuration of the valve (see form)
- Multifunctional module with integrated limit switches
- Pneumatic or electric actuators from +GF+

d [mm]	DN [mm]	PN	kv-value ($\Delta p=1$ bar) [l/min]	FPM Code	kg
16	10	16	71	175 546 411	0.195
20	15	16	185	175 546 412	0.200
25	20	16	350	175 546 413	0.300
32	25	16	700	175 546 414	0.440
40	32	16	1000	175 546 415	0.760
50	40	16	1600	175 546 416	1.060
63	50	16	3100	175 546 417	2.055

d [mm]	D [mm]	H [mm]	H1 [mm]	H2 [mm]	L [mm]	L1 [mm]	L2 [mm]	L4 [mm]	L5 [mm]	L6 [mm]	M	z [mm]
16	50	79	27	12	93	77	56	25	32	45	M6	67
20	50	57	27	12	95	77	56	25	32	45	M6	66
25	58	67	30	12	109	97	65	25	39	58	M6	77
32	68	73	36	12	119	97	71	25	39	58	M6	83
40	84	90	44	15	135	128	85	45	54	74	M8	99
50	97	97	51	15	147	128	89	45	54	74	M8	105
63	124	116	64	15	168	152	101	45	66	87	M8	117

PF 2 35 540



DN10/15 - 50

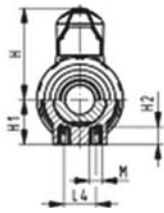
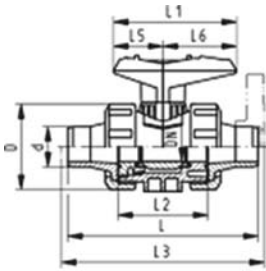

SYGEF® standard Ball valve type 546 PVDF With mounting inserts With socket fusion spigots metric

J

Model:

- For easy installation and removal
- z-dimension, valve end and valve nut are **not compatible** with type 346 (DN10/15-50) resp. type 370 (DN65-100)
- Ball seals PTFE
- Integrated stainless steel mounting inserts

Option:

- Individual configuration of the valve (see form)
- Multifunctional module with integrated limit switches
- Pneumatic or electric actuators from +GF+

d [mm]	DN [mm]	PN	kv-value ($\Delta p=1$ bar) [l/min]	FPM Code	kg
16	10	16	71	175 546 051	0.200
20	15	16	185	175 546 052	0.205
25	20	16	350	175 546 053	0.310
32	25	16	700	175 546 054	0.460
40	32	16	1000	175 546 055	0.780
50	40	16	1600	175 546 056	1.110
63	50	16	3100	175 546 057	2.150

d [mm]	D [mm]	H [mm]	H1 [mm]	H2 [mm]	L [mm]	L1 [mm]	L2 [mm]	L3 [mm]	L4 [mm]	L5 [mm]	L6 [mm]	M
16	50	57	27	12	110	77	56		25	32	45	M6
20	50	57	27	12	120	77	56	130	25	32	45	M6
25	58	67	30	12	139	97	65	150	25	39	58	M6
32	68	73	36	12	150	97	71	160	25	39	58	M6
40	84	90	44	15	170	128	85	180	45	54	74	M8
50	97	97	51	15	190	128	89	200	45	54	74	M8
63	124	116	64	15	220	152	101	230	45	66	87	M8

PF 2 35 540



SYGEF® standard
Ball valve type 546 PVDF
With mounting inserts
With fixed flanges PVDF serrated metric

J

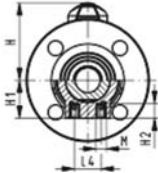
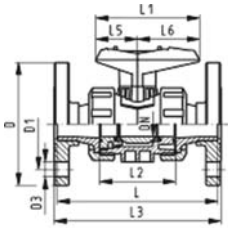

Model:

- For easy installation and removal
- z-dimension, valve end and valve nut are **not compatible** with type 346 (DN10/15-50) resp. type 370 (DN65-100)
- Ball seals PTFE
- Integrated stainless steel mounting inserts
- Overall length EN 558-1

Option:

- Individual configuration of the valve (see form)
- Multifunctional module with integrated limit switches
- Pneumatic or electric actuators from +GF+

d [mm]	DN [mm]	PN	kv-value ($\Delta p=1$ bar) [l/min]	FPM Code	kg
20	15	16	185	175 546 192	0.470
25	20	16	350	175 546 193	0.650
32	25	16	700	175 546 194	0.940
40	32	16	1000	175 546 195	1.570
50	40	16	1600	175 546 196	2.070
63	50	16	3100	175 546 197	3.490

d [mm]	D [mm]	D1 [mm]	D3 [mm]	H [mm]	H1 [mm]	H2 [mm]	L [mm]	L1 [mm]	L2 [mm]	L3 [mm]	L4 [mm]	L5 [mm]	L6 [mm]	M
20	93	65	14	57	27	12	120	77	56	130	25	32	45	M6
25	103	75	14	67	30	12	140	97	65	150	25	39	58	M6
32	115	85	14	73	36	12	150	97	71	160	25	39	58	M6
40	137	100	18	90	44	15	170	128	85	180	45	54	74	M8
50	147	110	18	97	51	15	190	128	89	200	45	54	74	M8
63	162	125	18	116	64	15	220	152	101	230	45	66	87	M8

PF 2 35 540



DN10/15 - 50

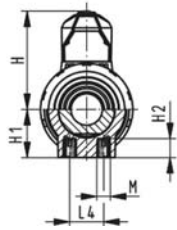
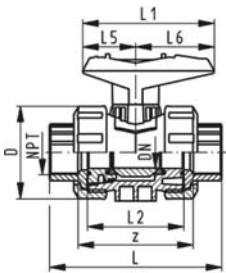

SYGEF® standard Ball valve type 546 PVDF With mounting inserts With threaded sockets NPT

J

Model:

- For easy installation and removal
- z-dimension, valve end and valve nut are **not compatible** with type 346 (DN10/15-50) resp. type 370 (DN65-100)
- Ball seals PTFE
- Integrated stainless steel mounting inserts

Option:

- Individual configuration of the valve (see form)
- Multifunctional module with integrated limit switches
- Pneumatic or electric actuators from +GF+

NPT [inch]	DN [mm]	PN	kv-value ($\Delta p=1$ bar) [l/min]	FPM Code	kg
3/8	10	10	71	175 546 331	0.205
1/2	15	10	185	175 546 332	0.220
3/4	20	10	350	175 546 333	0.325
1	25	10	700	175 546 334	0.490
1 1/4	32	10	1000	175 546 335	0.820
1 1/2	40	10	1600	175 546 336	1.135
2	50	10	3100	175 546 337	2.150

NPT [inch]	D [mm]	H [mm]	H1 [mm]	H2 [mm]	L [mm]	L1 [mm]	L2 [mm]	L4 [mm]	L5 [mm]	L6 [mm]	M	z [mm]
3/8	50	57	27	12	96	77	56	25	32	45	M6	69
1/2	50	57	27	12	99	77	56	25	32	45	M6	64
3/4	58	67	30	12	111	97	65	25	39	58	M6	76
1	68	73	36	12	127	97	71	25	39	58	M6	83
1 1/4	84	90	44	15	146	128	85	45	54	74	M8	101
1 1/2	97	97	51	15	157	128	89	45	54	74	M8	111
2	124	116	64	15	183	152	101	45	66	87	M8	135

PF 2 35 540



DN10/15 - 50

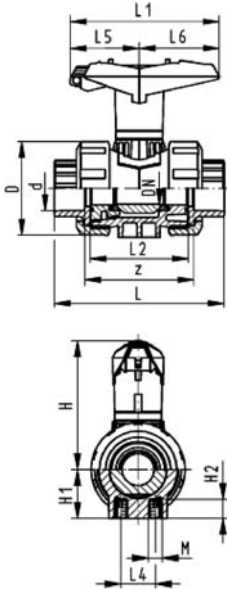

SYGEF® standard Ball valve type 546 PVDF With lockable handle With fusion sockets metric

J

Model:

- For easy installation and removal
- z-dimension, valve end and valve nut are **not compatible** with type 346 (DN10/15-50) resp. type 370 (DN65-100)
- Ball seals PTFE
- Integrated stainless steel mounting inserts
- Lockable hand lever with ratchet settings

Option:

- Individual configuration of the valve (see form)
- Multifunctional module with integrated limit switches
- Pneumatic or electric actuators from +GF+

d [mm]	DN [mm]	PN	kv-value ($\Delta p=1$ bar) [l/min]	FPM Code	kg
16	10	16	71	175 546 431	0.205
20	15	16	185	175 546 432	0.210
25	20	16	350	175 546 433	0.315
32	25	16	700	175 546 434	0.455
40	32	16	1000	175 546 435	0.785
50	40	16	1600	175 546 436	1.085
63	50	16	3100	175 546 437	2.085

d [mm]	D [mm]	H [mm]	H1 [mm]	H2 [mm]	L [mm]	L1 [mm]	L2 [mm]	L4 [mm]	L5 [mm]	L6 [mm]	M	z [mm]
16	50	79	27	12	93	77	56	25	32	45	M6	67
20	50	79	27	12	95	77	56	25	32	45	M6	66
25	58	88	30	12	109	97	65	25	39	58	M6	77
32	68	94	36	12	119	97	71	25	39	58	M6	83
40	84	113	44	15	135	128	85	45	54	74	M8	99
50	97	119	51	15	147	128	89	45	54	74	M8	105
63	124	141	64	15	168	152	101	45	66	87	M8	117

PF 2 35 540



DN10/15 - 50

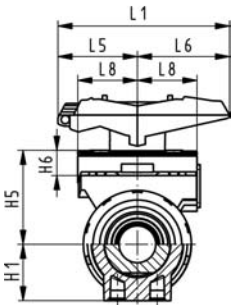
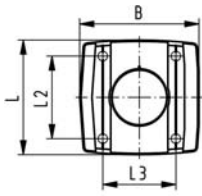

PF 2 31 798

Multifunctional module (I02) PP-GF Module empty

B

Model:

- Accessory to Ball Valve Type 546
- Multifunctional module acts as an intermediate element for actuators
- Including screws

d-d [mm]	DN-DN [mm]	Code	kg
16 - 20	10 - 15	167 482 680	0.055
25 - 32	20 - 25	167 482 681	0.070
40 - 50	32 - 40	167 482 682	0.080
- 63	- 50	167 482 683	0.120

d-d [mm]	B [mm]	H1 [mm]	H5 [mm]	H6 [mm]	L [mm]	L1 [mm]	L2 [mm]	L3 [mm]	L5 [mm]	L6 [mm]	L8 [mm]
16 - 20	67	27	50	17	72	87	54	40	42	45	34
25 - 32	75	30	53	16	72	108	52	46	50	58	38
40 - 50	81	44	72	16	80	140	60	50	66	75	41
- 63	91	64	94	19	93	165	68	65	78	87	46



DN10/15 - 50

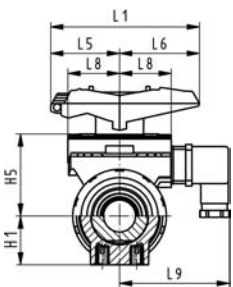

PF 2 31 798

Multifunctional module (I03) PP-GF With mechanical limit switches Ag Ni

B

Model:

- Accessory to Ball Valve Type 546
- Multifunctional module acts as an intermediate element for actuators
- Including Plug 3P+E / Protection: IP65
- Including screws

d-d [mm]	DN-DN [mm]	Code	kg	H1 [mm]	H5 [mm]	L1 [mm]	L5 [mm]	L6 [mm]	L8 [mm]	L9 [mm]
16 - 20	10 - 15	167 482 626	0.110	27	50	87	42	45	34	73
25 - 32	20 - 25	167 482 627	0.120	30	53	108	50	58	38	77
40 - 50	32 - 40	167 482 628	0.135	44	72	140	66	75	41	80
- 63	- 50	167 482 629	0.175	64	94	165	78	87	46	85



DN10/15 - 50

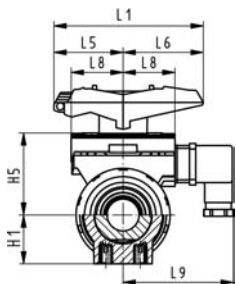

PF 2 31 798

Multifunctional module (I04) PP-GF With mechanical limit switches Au

B

Model:

- Accessory to Ball Valve Type 546
- Multifunctional module acts as an intermediate element for actuators
- Including Plug 3P+E / Protection: IP65
- Including screws

d-d [mm]	DN-DN [mm]	Code	kg	H1 [mm]	H5 [mm]	L1 [mm]	L5 [mm]	L6 [mm]	L8 [mm]	L9 [mm]
16 - 20	10 - 15	167 482 635	0.110	27	50	87	42	45	34	73
25 - 32	20 - 25	167 482 636	0.120	30	53	108	50	58	38	77
40 - 50	32 - 40	167 482 637	0.135	44	72	140	66	75	41	80
- 63	- 50	167 482 638	0.175	64	94	165	78	87	46	85



DN10/15 - 50

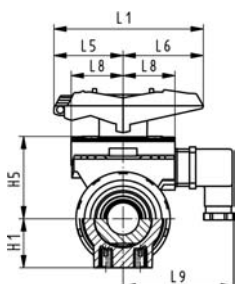

PF 2 31 798

Multifunctional module (I05) PP-GF With inductive limit switches Namur

B

Model:

- Accessory to Ball Valve Type 546
- Multifunctional module acts as an intermediate element for actuators
- Including Plug 3P+E / Protection: IP65
- Including screws

d-d [mm]	DN-DN [mm]	Code	kg	H1 [mm]	H5 [mm]	L1 [mm]	L5 [mm]	L6 [mm]	L8 [mm]	L9 [mm]
16 - 20	10 - 15	167 482 671	0.110	27	50	87	42	45	34	73
25 - 32	20 - 25	167 482 672	0.120	30	53	108	50	58	38	77
40 - 50	32 - 40	167 482 673	0.135	44	72	140	66	75	41	80
- 63	- 50	167 482 674	0.175	64	94	165	78	87	46	85



DN10/15 - 50

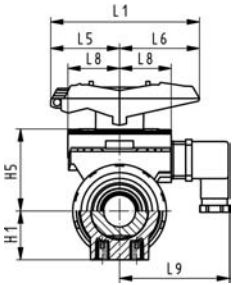

PF 2 31 798

Multifunctional module (I06) PP-GF With inductive limit switches PNP

B

Model:

- Accessory to Ball Valve Type 546
- Multifunctional module acts as an intermediate element for actuators
- Including Plug 3P+E / Protection: IP65
- Including screws

d-d [mm]	DN-DN [mm]	Code	kg	H1 [mm]	H5 [mm]	L1 [mm]	L5 [mm]	L6 [mm]	L8 [mm]	L9 [mm]
16 - 20	10 - 15	167 482 662	0.110	27	50	87	42	45	34	73
25 - 32	20 - 25	167 482 663	0.120	30	53	108	50	58	38	77
40 - 50	32 - 40	167 482 664	0.135	44	72	140	66	75	41	80
- 63	- 50	167 482 665	0.175	64	94	165	78	87	46	85



DN10/15 - 50

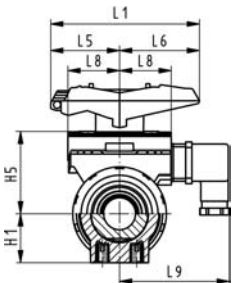

PF 2 31 798

Multifunctional module (I07) PP-GF With inductive limit switches NPN

B

Model:

- Accessory to Ball Valve Type 546
- Multifunctional module acts as an intermediate element for actuators
- Including Plug 3P+E / Protection: IP65
- Including screws

d-d [mm]	DN-DN [mm]	Code	kg	H1 [mm]	H5 [mm]	L1 [mm]	L5 [mm]	L6 [mm]	L8 [mm]	L9 [mm]
16 - 20	10 - 15	167 482 653	0.110	27	50	87	42	45	34	73
25 - 32	20 - 25	167 482 654	0.120	30	53	108	50	58	38	77
40 - 50	32 - 40	167 482 655	0.135	44	72	140	66	75	41	80
- 63	- 50	167 482 656	0.175	64	94	165	78	87	46	85



DN10/15 - 50

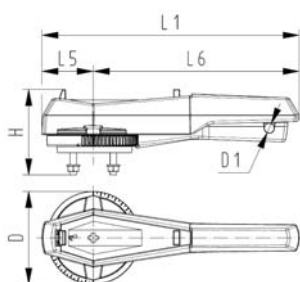
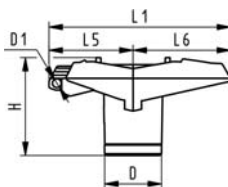

PF 2 31 798

Multifunctional handle 546 red (K11) With ratchet settings lockable

B

d-d [mm]	DN-DN [mm]	Code	kg	D [mm]	D1 [mm]	H [mm]	L1 [mm]	L5 [mm]	L6 [mm]
16 - 20	10 - 15	167 484 100	0.026	26	5	53	87	42	45
- 25	- 20	167 484 101	0.045	34	5	59	108	50	58
- 32	- 25	167 484 102	0.045	34	5	59	108	50	58
- 40	- 32	167 484 103	0.082	40	5	69	140	66	75
- 50	- 40	167 484 104	0.082	40	5	69	140	66	75
- 63	- 50	167 484 105	0.104	44	5	80	165	78	87

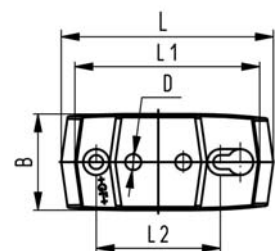
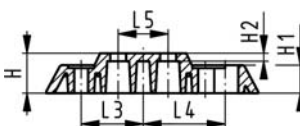

PF 2 31 798

Mounting plate 546 PP-GF (L02)

B

- 2 mounting screws inclusive

d-d [mm]	DN-DN [mm]	Code	kg
16 - 32	10 - 25	167 484 110	0.055
40 - 63	32 - 50	167 484 111	0.086

d-d [mm]	B [mm]	D [mm]	H [mm]	H1 [mm]	H2 [mm]	L [mm]	L1 [mm]	L2 [mm]	L3 [mm]	L4 [mm]	L5 [mm]
16 - 32	48	8	20	14	4	106	92	62	31	41	25
40 - 63	54	9	20	14	4	149	134	104	52	62	45



PF 2 31 798

Handle extension 546 PVC-U inch BS/ASTM

- For Ball Valve Type 546

DN-DN [mm]	Inch	Code	kg	H [mm]	H1 [mm]	H2 [mm]	H3 [mm]	D [mm]
10 - 15	3/8-1/2	161 486 443	0.032	41	52	29	36	26
20 - 25	3/4-1	161 486 444	0.037	50	62	32	39	36
32 - 40	1 1/4-1 1/2	161 486 445	0.047	65	76	34	44	40
50 -	2	161 486 446	0.058	84	87	37	48	44

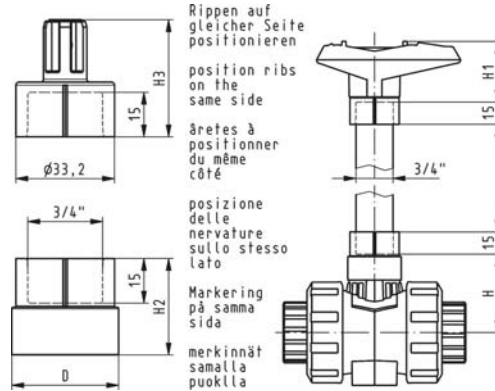

PF 2 31 798

Handle extension 546 PVC-U metric

B

Model:

- For Ball Valve Type 546
- Composed of adapter sockets for handle connection and stem connection
- PVC-U pipe in suitable length has to be obtained on site

d-d [mm]	DN-DN [mm]	Code	kg	H [mm]	H1 [mm]	H2 [mm]	H3 [mm]	D [mm]
16 - 20	10 - 15	161 486 435	0.032	41	52	29	36	26
25 - 32	20 - 25	161 486 436	0.037	50	62	32	39	36
40 - 50	32 - 40	161 486 437	0.047	65	76	34	44	40
- 63	- 50	161 486 438	0.058	84	87	37	48	44

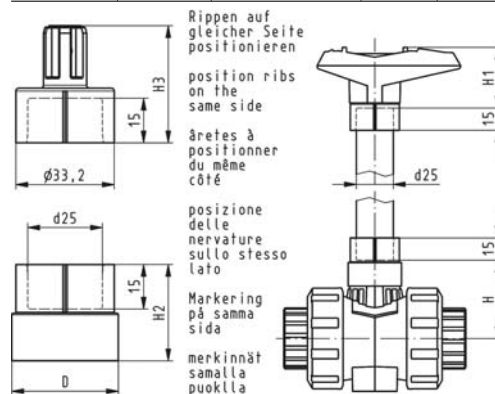



SYGEF® standard 3-Way ball valve type 343 PVDF Horizontal/L-port With butt fusion spigots metric

J

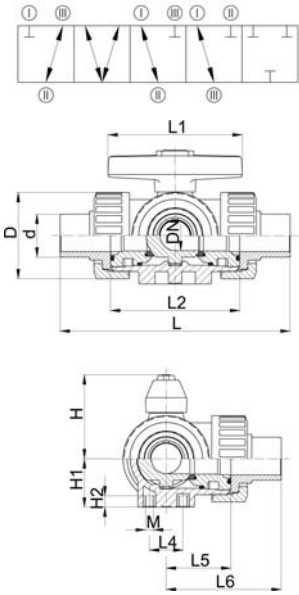

Model:

- L-port ball
- For easy installation and removal
- Ball seals PTFE
- Pneumatic or electric actuator available separately
- Angle of operation 360°, without turn limiter

d [mm]	DN [mm]	PN	kv-value ($\Delta p=1$ bar) [l/min]	FPM Code	kg
16	10	10	49	175 343 051	0.245
20	15	10	77	175 343 052	0.245
25	20	10	146	175 343 053	0.462
32	25	10	260	175 343 054	0.630
40	32	10	437	175 343 055	1.053
50	40	10	667	175 343 056	1.709
63	50	10	1293	175 343 057	3.310

d [mm]	D [mm]	H [mm]	H1 [mm]	H2 [mm]	L [mm]	L1 [mm]	L2 [mm]	L4 [mm]	L5 [mm]	L6 [mm]	M
16	46	50	27	8	119	78	70	25	36	60	M6
20	46	50	27	8	140	78	70	25	36	70	M6
25	56	60	33	8	156	92	86	25	43	78	M6
32	67	68	36	8	168	100	96	25	48	84	M6
40	82	79	44	9	198	110	114	45	58	99	M8
50	98	90	49	9	233	120	137	45	69	117	M8
63	121	109	61	9	285	146	179	45	90	143	M8

PF 2 35 491



SYGEF® standard 3-Way ball valve type 343 PVDF Horizontal/L-port With fusion sockets metric

J

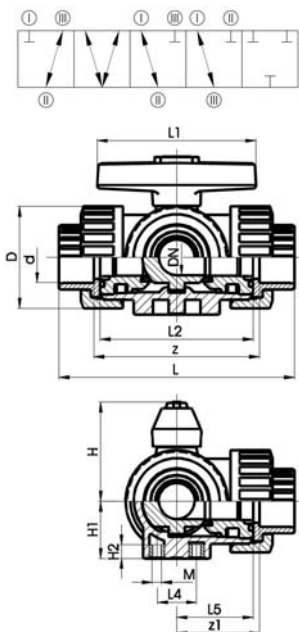

Model:

- L-port ball
- For easy installation and removal
- Ball seals PTFE
- Pneumatic or electric actuator available separately
- Angle of operation 360°, without turn limiter

d [mm]	DN [mm]	PN	kv-value ($\Delta p=1$ bar) [l/min]	FPM Code	kg
16	10	10	49	175 343 011	0.245
20	15	10	77	175 343 012	0.245
25	20	10	146	175 343 013	0.462
32	25	10	260	175 343 014	0.630
40	32	10	437	175 343 015	1.053
50	40	10	667	175 343 016	1.709
63	50	10	1293	175 343 017	3.310

d [mm]	z [mm]	z1 [mm]	D [mm]	H [mm]	H1 [mm]	H2 [mm]	L [mm]	L1 [mm]	L2 [mm]	L4 [mm]	L5 [mm]	M
16	78	39	46	50	27	8	108	78	70	25	36	M6
20	79	40	46	50	27	8	111	78	70	25	36	M6
25	95	48	56	60	33	8	131	92	86	25	43	M6
32	108	54	67	68	36	8	148	100	96	25	48	M6
40	133	67	82	79	44	9	177	110	114	45	58	M8
50	155	78	98	90	49	9	205	120	137	45	69	M8
63	203	102	121	109	61	9	261	146	179	45	90	M8

PF 2 35 491



SYGEF® standard
3-Way ball valve type 343 PVDF
Horizontal/L-port
With fusion spigots metric

J

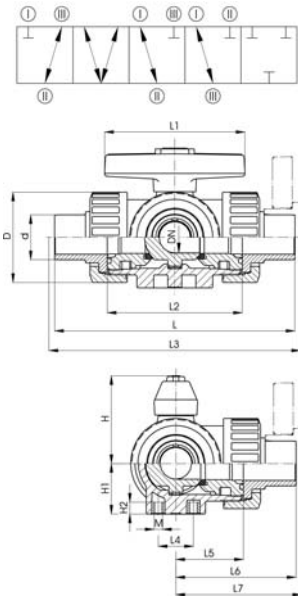

Model:

- L-port ball
- For easy installation and removal
- Ball seals PTFE
- Pneumatic or electric actuator available separately
- Angle of operation 360°, without turn limiter

d [mm]	DN [mm]	PN	kv-value ($\Delta p=1$ bar) [l/min]	FPM Code	kg
16	10	10	49	175 343 031	0.245
20	15	10	77	175 343 032	0.245
25	20	10	146	175 343 033	0.462
32	25	10	260	175 343 034	0.630
40	32	10	437	175 343 035	1.053
50	40	10	667	175 343 036	1.709
63	50	10	1293	175 343 037	3.310

d [mm]	D [mm]	H [mm]	H1 [mm]	H2 [mm]	L [mm]	L1 [mm]	L2 [mm]	L3 [mm]	L4 [mm]	L5 [mm]	L6 [mm]	L7 [mm]	M
16	46	50	27	8	119	78	70	130	25	36	60	65	M6
20	46	50	27	8	133	78	70	144	25	36	67	68	M6
25	56	60	33	8	155	92	86	165	25	43	78	79	M6
32	67	68	36	8	170	100	96	180	25	48	85	87	M6
40	82	79	44	9	201	110	114	209	45	58	101	102	M8
50	98	90	49	9	236	120	137	244	45	69	118	120	M8
63	121	109	61	9	286	146	179	295	45	90	143	150	M8

PF 2 35 491



SYGEF® standard 3-Way ball valve type 343 PVDF Horizontal/L-port With threaded sockets NPT

J

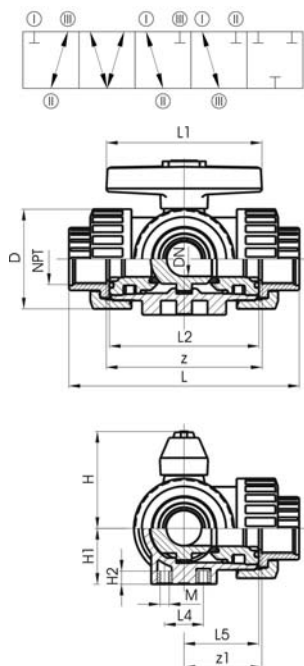

Model:

- L-port ball
- For easy installation and removal
- Ball seals PTFE
- Pneumatic or electric actuator available separately
- Angle of operation 360°, without turn limiter

NPT [inch]	DN [mm]	PN	kv-value ($\Delta p=1$ bar) [l/min]	FPM Code	kg
3/8	10	10	49	175 343 071	0.245
1/2	15	10	77	175 343 072	0.245
3/4	20	10	146	175 343 073	0.462
1	25	10	260	175 343 074	0.630
1 1/4	32	10	437	175 343 075	1.053
1 1/2	40	10	667	175 343 076	1.709
2	50	10	1293	175 343 077	3.310

NPT [inch]	z [mm]	z1 [mm]	D [mm]	H [mm]	H1 [mm]	H2 [mm]	L [mm]	L1 [mm]	L2 [mm]	L4 [mm]	L5 [mm]	M
3/8	76	38	46	50	27	8	108	78	70	25	36	M6
1/2	76	38	46	50	27	8	111	78	70	25	36	M6
3/4	90	45	56	60	33	8	131	92	86	25	43	M6
1	100	50	67	68	36	8	148	100	96	25	48	M6
1 1/4	122	61	82	79	44	9	176	110	114	45	58	M8
1 1/2	152	76	98	90	49	9	206	120	137	45	69	M8
2	200	100	116	109	61	9	262	146	179	45	90	M8

PF 2 35 491



SYGEF® standard 3-Way ball valve type 343 PVDF Horizontal/T-port With butt fusion spigots metric

J

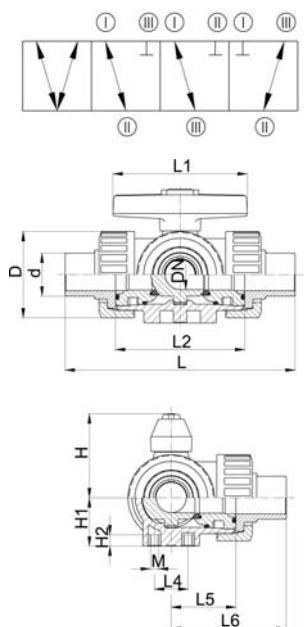

Model:

- T-port ball
- For easy installation and removal
- Ball seals PTFE
- Pneumatic or electric actuator available separately
- Angle of operation 90°, without turn limiter

d [mm]	DN [mm]	PN	kv-value ($\Delta p=1$ bar) [l/min]	FPM Code	kg
16	10	10	140	175 343 151	0.245
20	15	10	200	175 343 152	0.245
25	20	10	470	175 343 153	0.462
32	25	10	793	175 343 154	0.630
40	32	10	1290	175 343 155	1.053
50	40	10	1910	175 343 156	1.709
63	50	10	3100	175 343 157	3.310

d [mm]	D [mm]	H [mm]	H1 [mm]	H2 [mm]	L [mm]	L1 [mm]	L2 [mm]	L4 [mm]	L5 [mm]	L6 [mm]	M
16	46	50	27	8	119	78	70	25	36	60	M6
20	46	50	27	8	140	78	70	25	36	70	M6
25	56	60	33	8	156	92	86	25	43	78	M6
32	67	68	36	8	168	100	96	25	48	84	M6
40	82	79	44	9	198	110	114	45	58	99	M8
50	98	90	49	9	233	120	137	45	69	117	M8
63	121	109	61	9	285	146	179	45	90	143	M8

PF 2 35 492



SYGEF® standard 3-Way ball valve type 343 PVDF Horizontal/T-port With fusion sockets metric

J

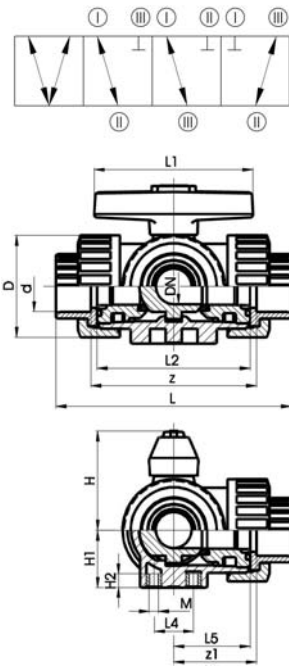

Model:

- T-port ball
- For easy installation and removal
- Ball seals PTFE
- Pneumatic or electric actuator available separately
- Angle of operation 90°, without turn limiter

d [mm]	DN [mm]	PN	kv-value ($\Delta p=1$ bar) [l/min]	FPM Code	kg
16	10	10	140	175 343 111	0.245
20	15	10	200	175 343 112	0.245
25	20	10	470	175 343 113	0.462
32	25	10	793	175 343 114	0.630
40	32	10	1290	175 343 115	1.053
50	40	10	1910	175 343 116	1.709
63	50	10	3100	175 343 117	3.310

d [mm]	z [mm]	z1 [mm]	D [mm]	H [mm]	H1 [mm]	H2 [mm]	L [mm]	L1 [mm]	L2 [mm]	L4 [mm]	L5 [mm]	M
16	78	39	46	50	27	8	108	78	70	25	36	M6
20	79	40	46	50	27	8	111	78	70	25	36	M6
25	95	48	56	60	33	8	131	92	86	25	43	M6
32	108	54	67	68	36	8	148	100	96	25	48	M6
40	133	67	82	79	44	9	177	110	114	45	58	M8
50	155	78	98	90	49	9	205	120	137	45	69	M8
63	203	102	121	109	61	9	261	146	179	45	90	M8

PF 2 35 492



SYGEF® standard 3-Way ball valve type 343 PVDF Horizontal/T-port With fusion spigots metric

J

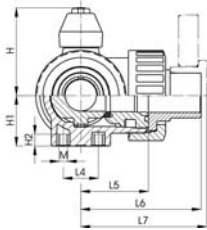
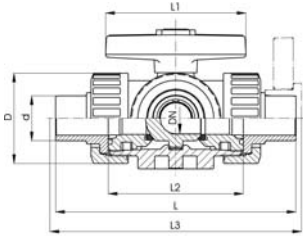
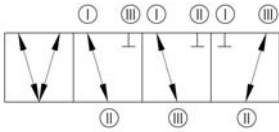

Model:

- T-port ball
- For easy installation and removal
- Ball seals PTFE
- Pneumatic or electric actuator available separately
- Angle of operation 90°, without turn limiter

d [mm]	DN [mm]	PN	kv-value ($\Delta p=1$ bar) [l/min]	FPM Code	kg
16	10	10	140	175 343 131	0.245
20	15	10	200	175 343 132	0.245
25	20	10	470	175 343 133	0.462
32	25	10	793	175 343 134	0.630
40	32	10	1290	175 343 135	1.053
50	40	10	1910	175 343 136	1.709
63	50	10	3100	175 343 137	3.310

d [mm]	D [mm]	H [mm]	H1 [mm]	H2 [mm]	L [mm]	L1 [mm]	L2 [mm]	L3 [mm]	L4 [mm]	L5 [mm]	L6 [mm]	L7 [mm]	M
16	46	50	27	8	119	78	70	130	25	36	60	65	M6
20	46	50	27	8	133	78	70	144	25	36	67	68	M6
25	56	60	33	8	155	92	86	165	25	43	78	79	M6
32	67	68	36	8	170	100	96	180	25	48	85	87	M6
40	82	79	44	9	201	110	114	209	45	58	101	102	M8
50	98	90	49	9	236	120	137	244	45	69	118	120	M8
63	121	109	61	9	286	146	179	295	45	90	143	150	M8

PF 2 35 492



SYGEF® standard 3-Way ball valve type 343 PVDF Horizontal/T-port With threaded sockets NPT

J

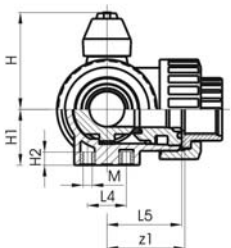
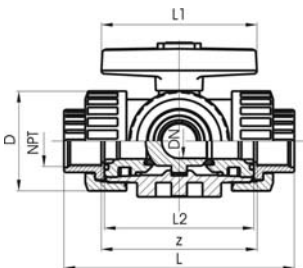
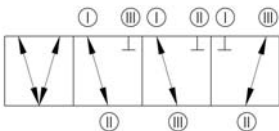

Model:

- T-port ball
- For easy installation and removal
- Ball seals PTFE
- Pneumatic or electric actuator available separately
- Angle of operation 90°, without turn limiter

NPT [inch]	DN [mm]	PN	kv-value ($\Delta p=1$ bar) [l/min]	FPM Code	kg
3/8	10	10	140	175 343 171	0.245
1/2	15	10	200	175 343 172	0.245
3/4	20	10	470	175 343 173	0.462
1	25	10	793	175 343 174	0.630
1 1/4	32	10	1290	175 343 175	1.053
1 1/2	40	10	1910	175 343 176	1.709
2	50	10	3100	175 343 177	3.310

NPT [inch]	z [mm]	z1 [mm]	D [mm]	H [mm]	H1 [mm]	H2 [mm]	L [mm]	L1 [mm]	L2 [mm]	L4 [mm]	L5 [mm]	M
3/8	76	38	46	50	27	8	108	78	70	25	36	M6
1/2	76	38	46	50	27	8	111	78	70	25	36	M6
3/4	90	45	56	60	33	8	131	92	86	25	43	M6
1	100	50	67	68	36	8	148	100	96	25	48	M6
1 1/4	122	61	82	79	44	9	176	110	114	45	58	M8
1 1/2	152	76	98	90	49	9	206	120	137	45	69	M8
2	200	100	121	109	61	9	262	146	179	45	90	M8

PF 2 35 492

Diaphragm valves

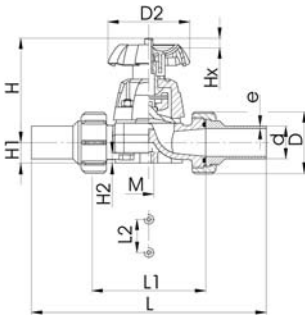

SYGEF® standard Diaphragm valve type 314 PVDF With butt fusion spigots metric

J

Model:

- Diaphragm PTFE with EPDM backing diaphragm (FDA compliant)
- For easy installation and removal
- Short overall length
- Welding dimension: PN16

Option:

- Handwheel with built-in locking mechanism (standard version is nonlockable)

d [mm]	DN [mm]	PN	kv-value ($\Delta p=1$ bar) [l/min]	PTFE with EPDM supp. Diaphragm Code	kg
20	15	10	72	175 314 532	0.485
25	20	10	137	175 314 533	0.710
32	25	10	207	175 314 534	0.970
40	32	10	354	175 314 535	1.545
50	40	10	517	175 314 536	2.040
63	50	10	713	175 314 537	3.537

d [mm]	D [mm]	D2 [mm]	e [mm]	H [mm]	H1 [mm]	H2 [mm]	L [mm]	L1 [mm]	L2 [mm]	M
20	45	80	1.9	90	14	12	196	90	25	M6
25	55	80	1.9	101	18	12	220	108	25	M6
32	62	94	2.4	117	22	12	234	116	25	M6
40	75	117	2.4	127	26	15	258	134	45	M8
50	84	117	3.0	139	32	15	284	154	45	M8
63	101	152	3.0	172	39	15	320	184	45	M8

PF 2 35 193

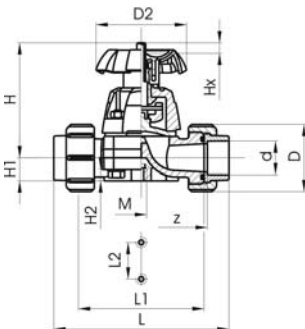

SYGEF® standard Diaphragm valve type 314 PVDF With fusion sockets metric

J

Model:

- Diaphragm PTFE with EPDM backing diaphragm (FDA compliant)
- For easy installation and removal
- Short overall length

Option:

- Handwheel with built-in locking mechanism (standard version is nonlockable)

d [mm]	DN [mm]	PN	kv-value ($\Delta p=1$ bar) [l/min]	PTFE with EPDM supp. Diaphragm Code	kg
20	15	10	72	175 314 432	0.470
25	20	10	137	175 314 433	0.687
32	25	10	207	175 314 434	0.935
40	32	10	354	175 314 435	1.500
50	40	10	517	175 314 436	1.960
63	50	10	713	175 314 437	3.470

d [mm]	D [mm]	D2 [mm]	H [mm]	H1 [mm]	H2 [mm]	L [mm]	L1 [mm]	L2 [mm]	M	z [mm]
20	45	80	90	14	12	128	90	25	M6	100
25	55	80	101	18	12	150	108	25	M6	118
32	62	94	117	22	12	162	116	25	M6	126
40	75	117	127	26	15	184	134	45	M8	144
50	84	117	139	32	15	210	154	45	M8	164
63	101	152	172	39	15	148	184	45	M8	194

PF 2 35 193



SYGEF® standard Diaphragm valve type 315 PVDF With butt fusion spigots metric

J

Model:

- Welding dimension: PN16
- Diaphragm PTFE with EPDM backing diaphragm (FDA compliant)
- Further versions : with diaphragm FPM on request

Option:

- Handwheel with built-in locking mechanism (standard version is nonlockable)

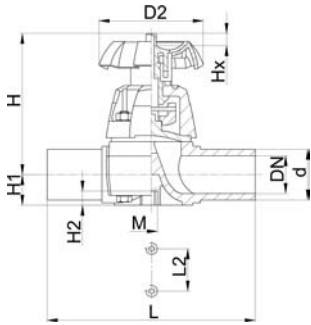

PF 2 35 193

d [mm]	DN [mm]	PN	kv-value ($\Delta p=1$ bar) [l/min]	PTFE with EPDM supp. diaphragm Code	kg	D2 [mm]	H [mm]	H1 [mm]	H2 [mm]	L [mm]	L2 [mm]	M
20	15	10	72	175 315 532	0.360	80	90	14	12	124	25	M6
25	20	10	137	175 315 533	0.560	80	102	18	12	144	25	M6
32	25	10	207	175 315 534	0.804	94	119	21	12	154	25	M6
40	32	10	354	175 315 535	1.025	117	126	26	15	174	45	M8
50	40	10	517	175 315 536	1.480	117	139	33	15	194	45	M8
63	50	10	713	175 315 537	2.581	152	172	39	15	224	45	M8



SYGEF® standard Diaphragm valve type 315 PVDF With socket fusion spigots metric

J

Model:

- Diaphragm PTFE with EPDM backing diaphragm (FDA compliant)
- Further versions : with diaphragm FPM on request

Option:

- Handwheel with built-in locking mechanism (standard version is nonlockable)

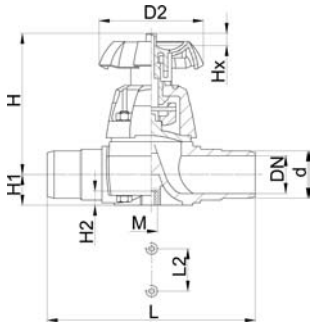

PF 2 35 193

d [mm]	DN [mm]	PN	kv-value ($\Delta p=1$ bar) [l/min]	PTFE with EPDM supp. diaphragm Code	kg	D2 [mm]	H [mm]	H1 [mm]	H2 [mm]	L [mm]	L2 [mm]	M
20	15	10	72	175 315 432	0.350	80	90	14	12	124	25	M6
25	20	10	137	175 315 433	0.570	80	102	18	12	144	25	M6
32	25	10	207	175 315 434	0.805	94	119	21	12	154	25	M6
40	32	10	354	175 315 435	1.000	117	126	26	15	174	45	M8
50	40	10	517	175 315 436	1.500	117	139	33	15	194	45	M8
63	50	10	713	175 315 437	2.680	152	172	39	15	224	45	M8



SYGEF® standard Diaphragm valve type 317 PVDF Flanged connection metric

J

Model:

- DN 15-65 with backing flange
- DN 80-150 with fixed flange
- Overall length according to EN 558-1
- Diaphragm PTFE with EPDM backing diaphragm (FDA compliant)

Option:

- Handwheel with built-in locking mechanism (standard version is nonlockable)

* DN80 and DN150 fixed flanges metric and Inch ANSI B16.5

d [mm]	DN [mm]	Inch	PN	kv-value ($\Delta p=1$ bar) [l/min]	PTFE with EPDM supp. diaphragm Code	kg
20	15	½	10	72	175 317 432	1.000
25	20	¾	10	137	175 317 433	0.858
32	25	1	10	207	175 317 434	1.000
40	32	1 ½	10	354	175 317 435	2.270
50	40	1 ½	10	517	175 317 436	2.260
63	50	2	10	713	175 317 437	3.700
75	65	2 ½	10	992	175 317 438	5.700
*90	80	3	10	1700	175 317 009	10.700
110	100	4	10	2700	175 317 010	14.890
*160	150	6	7	6033	175 317 012	33.500

d [mm]	D [mm]	D1 [mm]	D2 [mm]	D3 [mm]	H [mm]	H1 [mm]	H2 [mm]	Lift = Hx [mm]	L [mm]	L1 [mm]	L2 [mm]	L3 [mm]	M	AL
20	95	65	80	14	90	14	12	8	130		25		M6	4
25	105	75	80	14	102	18	12	11	150		25		M6	4
32	115	85	94	14	119	21	12	13	160		25		M6	4
40	140	100	117	18	126	26	15	16	180		45		M8	4
50	150	110	117	18	139	33	15	21	200		45		M8	4
63	165	125	152	18	172	39	15	28	230		45		M8	4
75	185	145	152	18	201	46	15	30	290		70		M8	4
*90	200	160	270	18	265	57	23	40	310	35	120		M12	8
110	225	180	270	18	302	68	23	50	350	35	120		M12	8
*160	285	240	400	22	437	108	23	70	480	26	100	200	M12	8

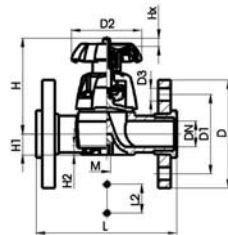

DN 15-65

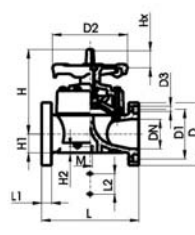

DN 80-100

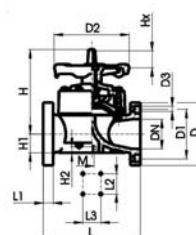

DN 150

PF 2 35 193



SYGEF® standard Diaphragm valve type 317 PVDF Flanged connection ANSI

J

Model:

- DN 15-65 with backing flange
- DN 80-150 with fixed flange
- Overall length according to EN 558-1
- Diaphragm PTFE with EPDM backing diaphragm (FDA compliant)

Option:

- Handwheel with built-in locking mechanism (standard version is nonlockable)

* DN80 and DN150 fixed flanges metric and Inch ANSI B16.5

d [mm]	DN [mm]	Inch	PN	kv-value ($\Delta p=1$ bar) [l/min]	PTFE with EPDM supp. diaphragm Code	kg
20	15	½	10	72	175 317 532	0.550
25	20	¾	10	137	175 317 533	1.210
32	25	1	10	207	175 317 534	1.210
40	32	1 ¼	10	354	175 317 535	2.270
50	40	1 ½	10	517	175 317 536	2.280
63	50	2	10	713	175 317 537	3.681
75	65	2 ½	10	992	175 317 538	6.000
*90	80	3	10	1700	175 317 339	
*110	100	4	10	2700	175 317 340	14.950

d [mm]	D [mm]	D1 [mm]	D2 [mm]	D3 [mm]	H [mm]	H1 [mm]	H2 [mm]	Lift = Hx [mm]	L [mm]	L1 [mm]	L2 [mm]	L3 [mm]	M	AL
20	95	61	80	14	90	14	12	8	130		25		M6	4
25	105	70	80	14	93	18	12	11	150		25		M6	4
32	115	80	94	14	119	21	12	13	160		25		M6	4
40	140	89	117	18	126	26	15	16	180		45		M8	4
50	150	99	117	18	139	33	15	21	200		45		M8	4
63	165	121	152	18	172	39	15	28	230		45		M8	4
75	185	140	152	18	201	46	15	30	290		70		M8	4
*90	200	152	270	18	265	57	23	40	310	35	120		M12	8
*110	225	191	270	18	304	69	23	50	350	35	120		M12	8

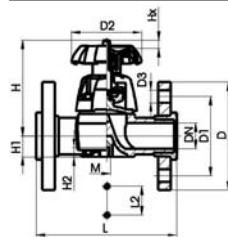

DN 15-65

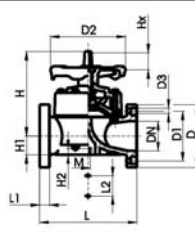

DN 80-100

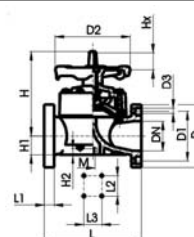

DN 150

PF 2 35 193

Butterfly valves

SYGEF® standard Butterfly valve type 567 PVDF Hand lever with ratchet settings

J

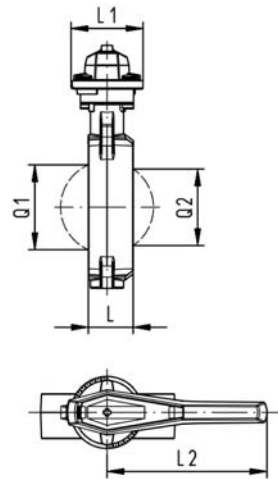
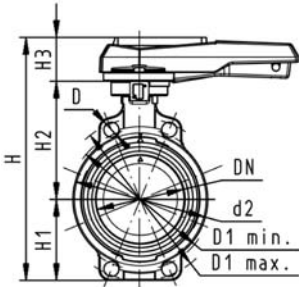

Model:

- Connecting dimension: ISO 7005 PN 10, EN 1092 PN 10, DIN 2501 PN 10, ANSI B 16.5 Class 150, BS 1560: 1989, BS 4504, JIS B 2220
- Overall length according to EN 558-1, ISO 5752

d [mm]	DN [mm]	Inch	PN	kv-value ($\Delta p=1$ bar) [l/min]	FPM Code	kg
63	50	2	10	1470	175 567 002	1.080
75	65	2 ½	10	2200	175 567 003	1.192
90	80	3	10	3000	175 567 004	1.372
110	100	4	10	6500	175 567 005	2.072
140	125	5	10	11500	175 567 006	2.667
160	150	6	10	16600	175 567 007	3.887
225	200	8	10	39600	175 567 008	6.545

d [mm]	D [mm]	D1 min. [mm]	D1 max. [mm]	d2 [mm]	H [mm]	H1 [mm]	H2 [mm]	H3 [mm]	L [mm]	L1 [mm]	L2 [mm]	Q1 [mm]	Q2 [mm]
63	19	120.0	125.0	104	264	77	134	54	45	106	205	40	
75	19	139.7	145.0	115	277	83	140	54	46	106	205	54	35
90	19	150.0	160.0	131	289	89	146	54	49	106	205	67	50
110	19	175.0	190.5	161	325	104	167	55	56	106	255	88	74
140	23	210.0	215.9	187	352	117	181	55	64	106	255	113	97
160	24	241.3	241.3	215	373	130	189	55	72	106	255	139	123
225	23	290.0	295.0	267	435	158	210	67	73	140	408	178	169

PF 2 35 566



SYGEF® standard Butterfly valve type 567 PVDF Reduction gear with handwheel

J

Model:

- Connecting dimension: ISO 7005 PN 10, EN 1092 PN 10, DIN 2501 PN 10, ANSI B 16.5 Class 150, BS 1560: 1989, BS 4504, JIS B 2220
- Overall length according to EN 558-1, ISO 5752

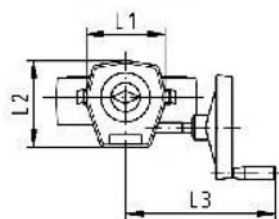
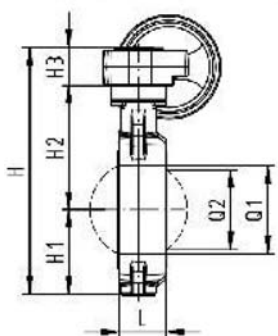
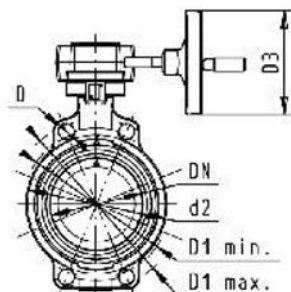

d [mm]	DN [mm]	Inch	PN	kv-value ($\Delta p=1$ bar) [l/min]	FPM Code	kg
63	50	2	10	1470	175 567 022	3.118
75	65	2 ½	10	2200	175 567 023	3.230
90	80	3	10	3000	175 567 024	3.410
110	100	4	10	6500	175 567 025	4.062
140	125	5	10	11500	175 567 026	4.657
160	150	6	10	16600	175 567 027	5.877
225	200	8	10	39600	175 567 028	7.998

d [mm]	D [mm]	D1 min. [mm]	D1 max. [mm]	d2 [mm]	D3 [mm]	H [mm]	H1 [mm]	H2 [mm]	H3 [mm]	L [mm]	L1 [mm]	L2 [mm]	L3 [mm]	Q1 [mm]
63	19	120.0	125.0	104	160	278	77	134	68	45	120	132	236	40
75	19	139.7	145.0	115	160	291	83	140	68	46	120	132	236	54
90	19	150.0	160.0	131	160	303	89	146	68	49	120	132	236	67
110	19	175.0	190.5	160	160	339	104	167	68	56	120	132	236	88
140	23	210.0	215.9	187	160	365	117	181	68	64	120	132	236	113
160	24	241.3	241.3	215	160	387	130	189	68	72	120	132	236	139
225	23	290.0	295.0	267	160	436	158	210	68	73	120	132	236	178

d [mm]	Q2 [mm]
63	
75	35
90	50
110	74
140	97
160	123
225	169

PF 2 35 566



SYGEF® standard Butterfly valve type 567 PVDF Bare shaft

Model:

- Connecting dimension: ISO 7005 PN 10, EN 1092 PN 10, DIN 2501 PN 10, ANSI B 16.5 Class 150, BS 1560: 1989, BS 4504, JIS B 2220
- Overall length according to EN 558-1, ISO 5752
- Interface F07 according to DIN/ISO 5211

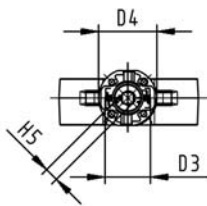
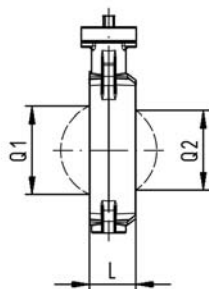
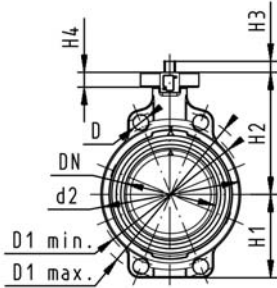

d [mm]	DN [mm]	Inch	PN	kv-value ($\Delta p=1$ bar) [l/min]	FPM Code	kg
63	50	2	10	1470	175 567 822	0.858
75	65	2 ½	10	2200	175 567 823	0.970
90	80	3	10	3000	175 567 824	1.150
110	100	4	10	6500	175 567 825	1.802
140	125	5	10	11500	175 567 826	2.397
160	150	6	10	16600	175 567 827	3.617
225	200	8	10	39600	175 567 828	5.738

d [mm]	D [mm]	D1 min. [mm]	D1 max. [mm]	d2 [mm]	D3 [mm]	D4 [mm]	H [mm]	H1 [mm]	H2 [mm]	H3 [mm]	H4 [mm]	H5 [mm]	L [mm]	Q1 [mm]
63	19	120.0	125.0	104	70	90	222	77	134	27	23	11	45	40
75	19	139.7	145.0	115	70	90	235	83	140	27	23	11	46	54
90	19	150.0	160.0	131	70	90	247	89	146	27	23	11	49	67
110	19	175.0	190.5	161	70	90	287	104	167	16	23	14	56	88
140	23	210.0	215.9	187	70	90	313	117	181	16	23	14	64	113
160	24	241.3	241.3	215	70	90	335	130	189	19	23	17	72	139
225	23	290.0	295.0	267	70	90	387	158	210	19	23	17	73	178

d [mm]	Q2 [mm]
63	
75	35
90	50
110	74
140	97
160	123
225	169

PF 2 35 569



SYGEF® standard Lugstyle butterfly valve type 568 PVDF Hand lever with ratchet settings

J

Model:

- Outer body in GGG-40.3 epoxy-coated
- Connecting dimension: ISO 7005 PN10, EN 1092 PN 10, DIN 2501 PN10
- Overall length according to EN 558-1, ISO 5752

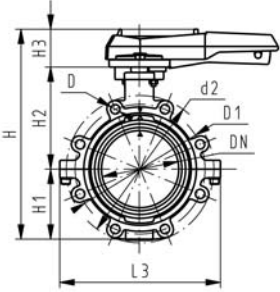

d [mm]	DN [mm]	Inch	PN	kv-value ($\Delta p=1$ bar) [l/min]	FPM Code	kg
63	50	2	10	1470	175 568 002	3.170
75	65	2 ½	10	2200	175 568 003	3.533
90	80	3	10	3000	175 568 004	4.590
110	100	4	10	6500	175 568 005	6.170
140	125	5	10	11500	175 568 006	8.151
160	150	6	10	16600	175 568 007	10.370
225	200	8	10	39600	175 568 008	16.521

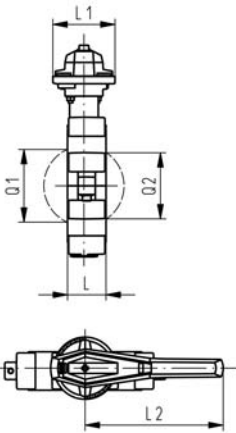

d [mm]	d2 [mm]	D	D1 [mm]	H [mm]	H1 [mm]	H2 [mm]	H3 [mm]	L [mm]	L1 [mm]	L2 [mm]	L3 [mm]	Q1 [mm]	Q2 [mm]
63	150	M16	125	265	77	134	54	45	106	205	150	40	
75	170	M16	145	277	83	140	54	46	106	205	160	54	35
90	184	M16	160	289	89	146	54	49	106	205	205	67	50
110	216	M16	180	326	104	167	55	56	106	255	244	88	74
140	246	M16	210	353	117	181	55	64	106	255	272	113	97
160	273	M20	240	374	130	189	55	72	106	255	297	139	123
225	334	M20	295	435	158	210	67	73	140	408	360	178	169

PF 2 35 569

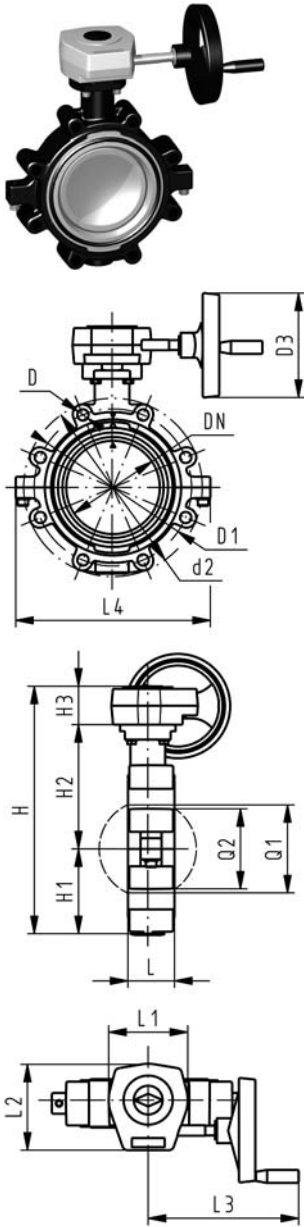

SYGEF® standard Lugstyle butterfly valve type 568 PVDF Reduction gear with handwheel

J

Model:

- Outer body in GGG-40.3 epoxy-coated
- Connecting dimension: ISO 7005 PN10, EN 1092 PN 10, DIN 2501 PN10
- Overall length according to EN 558-1, ISO 5752

d [mm]	DN [mm]	Inch	PN	kv-value ($\Delta p=1$ bar) [l/min]	FPM Code	kg
63	50	2	10	1470	175 568 022	5.208
75	65	2 ½	10	2200	175 568 023	5.571
90	80	3	10	3000	175 568 024	6.628
110	100	4	10	6500	175 568 025	8.160
140	125	5	10	11500	175 568 026	10.141
160	150	6	10	16600	175 568 027	12.360
225	200	8	10	39600	175 568 028	17.974

d [mm]	d2 [mm]	D	D1 [mm]	D3 [mm]	H [mm]	H1 [mm]	H2 [mm]	H3 [mm]	L [mm]	L1 [mm]	L2 [mm]	L3 [mm]	L4 [mm]	Q1 [mm]	Q2 [mm]
63	150	M16	125	160	279	77	134	68	45	120	132	236	150	40	
75	170	M16	145	160	291	83	140	68	46	120	132	236	160	54	35
90	184	M16	160	160	303	89	146	68	49	120	132	236	205	67	50
110	216	M16	180	160	339	104	167	68	56	120	132	236	244	88	74
140	246	M16	210	160	366	117	181	68	64	120	132	236	272	113	97
160	273	M20	240	160	387	130	189	68	72	120	132	236	297	139	123
225	334	M20	295	160	436	158	210	68	73	120	132	236	360	178	169

PF 2 35 569



SYGEF® standard Lugstyle butterfly valve type 568 PVDF Bare shaft

Model:

- Outer body in GGG-40.3 epoxy-coated
- Connecting dimension: ISO 7005 PN10, EN 1092 PN 10, DIN 2501 PN10
- Overall length according to EN 558-1, ISO 5752
- Interface F07 according to DIN/ISO 5211

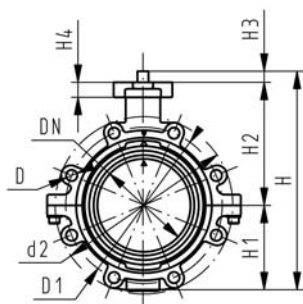

d [mm]	DN [mm]	Inch	PN	kv-value ($\Delta p=1$ bar) [l/min]	FPM Code	kg
63	50	2	10	1470	175 568 822	2.948
75	65	2 ½	10	2200	175 568 823	3.311
90	80	3	10	3000	175 568 824	4.368
110	100	4	10	6500	175 568 825	5.900
140	125	5	10	11500	175 568 826	7.881
160	150	6	10	16600	175 568 827	10.100
225	200	8	10	39600	175 568 828	15.714

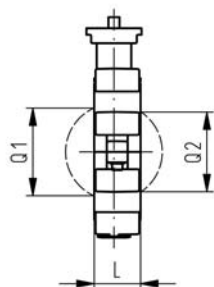

d [mm]	d2 [mm]	D	D1 [mm]	D3 [mm]	D4 [mm]	H [mm]	H1 [mm]	H2 [mm]	H3 [mm]	H4 [mm]	L [mm]	Q1 [mm]	Q2 [mm]
63	150	M16	125	70	90	222	77	134	27	23	45	40	
75	170	M16	145	70	90	235	83	140	27	23	46	54	35
90	184	M16	160	70	90	247	89	146	27	23	49	67	50
110	216	M16	180	70	90	287	104	167	16	23	56	88	74
140	246	M16	210	70	90	313	117	181	16	23	64	113	97
160	273	M20	240	70	90	335	130	189	19	23	72	139	123
225	334	M20	295	70	90	387	158	210	19	23	73	178	169

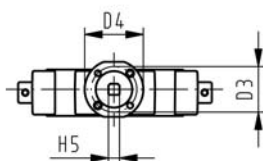

PF 2 35 569



SYGEF® standard Lugstyle butterfly valve 568 PVDF ANSI Hand lever with ratchet settings

Model:

- Outer body in GGG-40.3 epoxy-coated
- Connecting dimension ANSI B 16.5 Class 150
- Overall length according to EN 558-1, ISO 5752

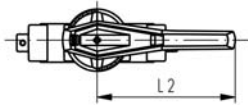
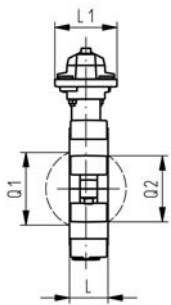
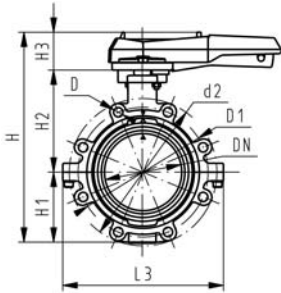

Inch	d [mm]	DN [mm]	PN	kv-value ($\Delta p=1$ bar) [l/min]	FPM Code	kg
2	63	50	10	1470	175 568 102	3.170
2 ½	75	65	10	2200	175 568 103	3.533
3	90	80	10	3000	175 568 104	3.961
4	110	100	10	6500	175 568 105	6.170
5	140	125	10	11500	175 568 106	8.151
6	160	150	10	16600	175 568 107	10.370
8	225	200	10	39600	175 568 108	16.521

Inch	d2 [mm]	D	D1 [mm]	H [mm]	H1 [mm]	H2 [mm]	H3 [mm]	L [mm]	L1 [mm]	L2 [mm]	L3 [mm]	Q1 [mm]	Q2 [mm]
2	150	UNC 5/8	121	265	77	134	54	45	106	205	150	40	
2 ½	170	UNC 5/8	138	277	83	140	54	46	106	205	160	54	35
3	177	UNC 5/8	152	289	89	146	54	49	106	205	175	67	50
4	216	UNC 5/8	191	326	104	167	55	56	106	255	244	88	74
5	246	UNC 3/4	216	353	117	181	55	64	106	255	272	113	97
6	273	UNC 3/4	241	374	130	189	55	72	106	255	297	139	123
8	334	UNC 3/4	298	435	158	210	67	73	140	408	360	178	169

PF 2 35 569



SYGEF® standard Lugstyle butterfly valve 568 PVDF ANSI Reduction gear with handwheel

Model:

- Outer body in GGG-40.3 epoxy-coated
- Connecting dimension ANSI B 16.5 Class 150
- Overall length according to EN 558-1, ISO 5752

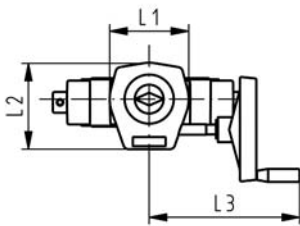
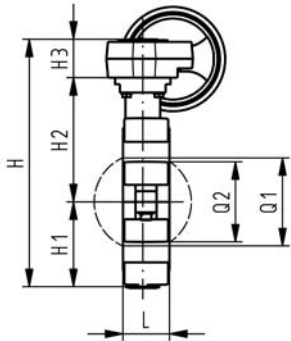
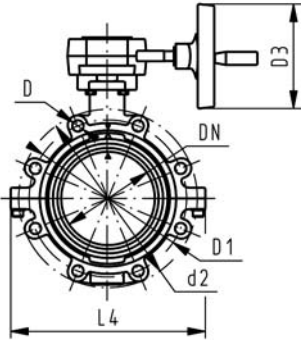

Inch	d [mm]	DN [mm]	PN	kv-value ($\Delta p=1$ bar) [l/min]	FPM Code	kg
2	63	50	10	1470	175 568 122	5.208
2 ½	75	65	10	2200	175 568 123	5.571
3	90	80	10	3000	175 568 124	5.999
4	110	100	10	6500	175 568 125	8.160
5	140	125	10	11500	175 568 126	10.141
6	160	150	10	16600	175 568 127	12.360
8	225	200	10	39600	175 568 128	17.974

Inch	d2 [mm]	D	D1 [mm]	D3 [mm]	H [mm]	H1 [mm]	H2 [mm]	H3 [mm]	L [mm]	L1 [mm]	L2 [mm]	L3 [mm]	L4 [mm]	Q1 [mm]
2	150	UNC 5/8	121	160	279	77	134	68	45	120	132	236	150	40
2 ½	170	UNC 5/8	138	160	291	83	140	68	46	120	132	236	160	54
3	177	UNC 5/8	152	160	303	89	146	68	49	120	132	236	175	67
4	216	UNC 5/8	191	160	339	104	167	68	56	120	132	236	244	88
5	246	UNC 3/4	216	160	366	117	181	68	64	120	132	236	272	113
6	273	UNC 3/4	241	160	387	130	189	68	72	120	132	236	297	139
8	334	UNC 3/4	298	160	436	158	210	68	73	120	132	236	360	178

Inch	Q2 [mm]
2	
2 ½	35
3	50
4	74
5	97
6	123
8	169

PF 2 35 569



SYGEF® standard Lugstyle butterfly valve 568 PVDF ANSI Bare shaft

Model:

- Outer body in GGG-40.3 epoxy-coated
- Connecting dimension ANSI B 16.5 Class 150
- Overall length according to EN 558-1, ISO 5752
- Interface F07 according to DIN/ISO 5211

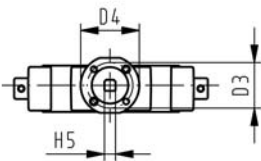
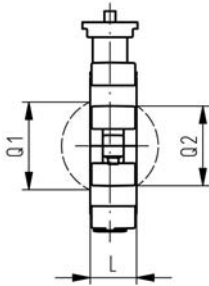
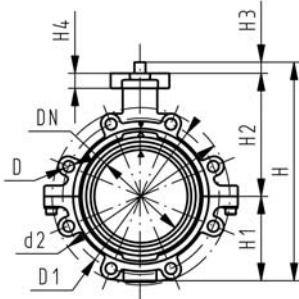

Inch	d [mm]	DN [mm]	PN	kv-value ($\Delta p=1$ bar) [l/min]	FPM Code	kg
2	63	50	10	1470	175 568 922	2.948
2 ½	75	65	10	2200	175 568 923	3.311
3	90	80	10	3000	175 568 924	3.739
4	110	100	10	6500	175 568 925	5.900
5	140	125	10	11500	175 568 926	7.881
6	160	150	10	16600	175 568 927	10.100
8	225	200	10	39600	175 568 928	15.714

Inch	d2 [mm]	D	D1 [mm]	D3 [mm]	D4 [mm]	H [mm]	H1 [mm]	H2 [mm]	H3 [mm]	H4 [mm]	L [mm]	Q1 [mm]	Q2 [mm]
2	150	UNC 5/8	121	70	90	222	77	134	27	23	45	40	
2 ½	170	UNC 5/8	138	70	90	235	83	140	27	23	46	54	35
3	177	UNC 5/8	152	70	90	247	89	146	27	23	49	67	50
4	216	UNC 5/8	191	70	90	287	104	167	16	23	56	88	74
5	246	UNC 3/4	216	70	90	313	117	181	16	23	64	113	97
6	273	UNC 3/4	241	70	90	335	130	189	19	23	72	139	123
8	334	UNC 3/4	298	70	90	387	158	210	19	23	73	178	169

PF 2 35 569

Ball check valves

SYGEF® standard Ball check valve type 360 PVDF With butt fusion spigots metric

J

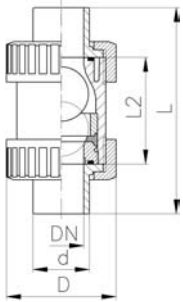

PF 2 35 195

Model:

- For easy installation and removal
- Ball is sealing at a minimum water column 1m
- Vibration free even at high flow velocity
- FPM ball seal

Attention; make sure the inner diameter is not reduced by leaving residues of the fusion (danger of turbulence)

d [mm]	DN [mm]	PN	kv-value ($\Delta p=1$ bar) [l/min]	FPM Code	kg	D [mm]	L [mm]	L2 [mm]	
20	15	16	150	175 360 492	0.156	46	130	62	
25	20	16	330	175 360 493	0.259	56	144	74	
32	25	16	390	175 360 494	0.406	67	150	78	
40	32	16	710	175 360 495	0.676	82	171	88	
50	40	16	900	175 360 496	1.086	98	191	94	
63	50	16	1390	175 360 497	2.029	120	220	113	

SYGEF® standard Ball check valve type 360 PVDF With fusion sockets metric

J

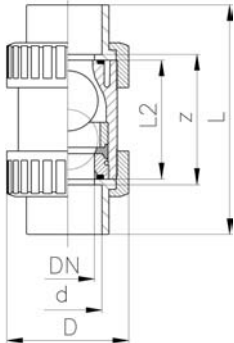

PF 2 35 195

Model:

- For easy installation and removal
- Ball is sealing at a minimum water column 1m
- Vibration free even at high flow velocity
- FPM ball seal

Attention; make sure the inner diameter is not reduced by leaving residues of the fusion (danger of turbulence)

d [mm]	DN [mm]	PN	kv-value ($\Delta p=1$ bar) [l/min]	FPM Code	kg	D [mm]	L [mm]	L2 [mm]	z [mm]	
16	10	16	170	175 360 411	0.152	46	98	62	72	
20	15	16	150	175 360 412	0.153	46	101	62	73	
25	20	16	330	175 360 413	0.253	56	119	74	87	
32	25	16	390	175 360 414	0.395	67	130	78	94	
40	32	16	710	175 360 415	0.625	82	149	88	109	
50	40	16	900	175 360 416	1.045	98	162	94	116	
63	50	16	1390	175 360 417	1.990	120	195	113	141	



SYGEF® standard Ball check valve type 360 PVDF With socket fusion spigots metric

J

Model:

- For easy installation and removal
- Ball is sealing at a minimum water column 1m
- Vibration free even at high flow velocity
- FPM ball seal

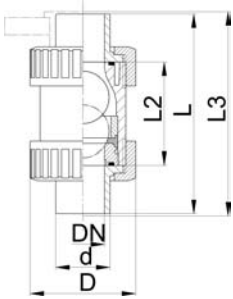

Attention; make sure the inner diameter is not reduced by leaving residues of the fusion (danger of turbulence)

d [mm]	DN [mm]	PN	kv-value ($\Delta p=1$ bar) [l/min]	FPM Code	kg	D [mm]	L [mm]	L2 [mm]	L3 [mm]
16	10	16	170	175 360 451	0.155	46	109	62	120
20	15	16	150	175 360 452	0.156	46	119	62	130
25	20	16	330	175 360 453	0.259	56	140	74	150
32	25	16	390	175 360 454	0.406	67	150	78	160
40	32	16	710	175 360 455	0.676	82	171	88	180
50	40	16	900	175 360 456	1.086	98	191	94	200
63	50	16	1390	175 360 457	2.029	120	220	113	230

PF 2 35 195

Check valves

SYGEF® standard Wafer check valve type 369 PVDF Without springs

J

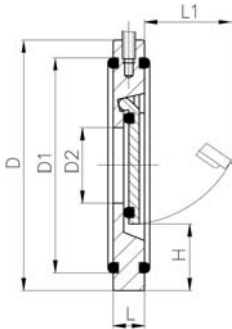

Installation instruction:

- Installation between metric flange adaptors with smooth jointing face
- Centering by body diameter
- Supporting eyelets for simple mounting
- Sealing with O-rings
- Suitable for vertical and horizontal mounting
- A stabilizing zone of at least 5 times nominal diameter (DN) should be provided before and after the wafer check valve (10 times DN is recommended)
- No direct installation on pump flange or following bend allowed
- Wafer check valves without reset spring are not recommended for pulsating flows (production of noise)

Note:

- In order to install the wafer check valves properly, Georg Fischer recommends flange adaptors of the next larger diameter of the valve (e.g. wafer check valve d90 with two flange adaptors d110)

d [mm]	DN [mm]	PN	FPM Code	kg
40	32	6	175 369 022	0.170
50	40	6	175 369 023	0.210
63	50	6	175 369 024	0.330
75	65	6	175 369 025	0.420
90	80	6	175 369 026	0.510
110	100	6	175 369 027	0.710
140	125	6	175 369 029	0.970
160	150	6	175 369 030	1.420
225	200	6	175 369 031	2.710
280	250	6	175 369 032	4.520
315	300	6	175 369 033	6.900

d [mm]	D [mm]	D1 [mm]	D2 [mm]	H [mm]	L [mm]	L1 [mm]	Opening pressure vertical without spring in [mbar]	Opening pressure horizontal without spring in [mbar]	Tightness from water column in m - PVDF [m H ₂ O]
40	85	59	18	25	15	22	10	1	2.0
50	95	72	22	28	16	25	10	1	2.0
63	109	86	32	29	18	37	10	1	2.0
75	129	105	40	31	20	50	10	1	2.0
90	144	119	54	32	20	61	10	1	2.0
110	164	146	70	31	23	77	10	1	2.0
140	195	173	92	35	23	94	10	1	2.0
160	220	197	112	35	26	115	10	1	2.0
225	275	255	154	38	35	152	18	1	2.0
280	330	312	192	41	40	180	18	1	2.0
315	380	363	227	41	45	215	18	1	2.0

d [mm]	Number of screws with washer	Torque [Nm]	Number of nut rotations after tightening by hand
40	4xM16/90	10	1
50	4xM16/95	12	1
63	4xM16/110	15	1
75	4xM16/140	18	1
90	8xM16/150	20	1
110	8xM16/160	22	1
140	8xM16/180	25	1
160	8xM20/200	30	1
225	8xM20/220	60	1
280	12xM20/240	60	1
315	12xM20/160	60	1

PF 2 35 195

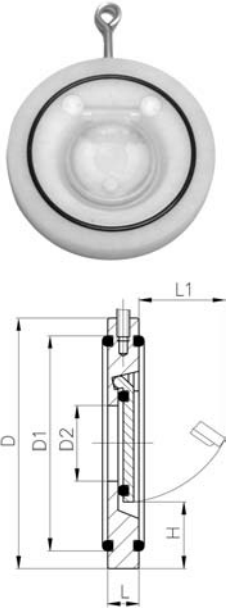

SYGEF® standard Wafer check valve type 369 PVDF With V4A springs

J

Installation instruction:

- Installation between metric flange adaptors with smooth jointing face
- Centering by body diameter
- Supporting eyelets for simple mounting
- Sealing with O-rings
- Suitable for vertical and horizontal mounting
- A stabilizing zone of at least 5 times nominal diameter (DN) should be provided before and after the wafer check valve (10 times DN is recommended)
- No direct installation on pump flange or following bend allowed
- Wafer check valves without reset spring are not recommended for pulsating flows (production of noise)

Note:

- In order to install the wafer check valves properly, Georg Fischer recommends flange adaptors of the next larger diameter of the valve (e.g. wafer check valve d90 with two flange adaptors d110)

d [mm]	DN [mm]	PN	FPM Code	kg
40	32	6	175 369 062	0.170
50	40	6	175 369 063	0.210
63	50	6	175 369 064	0.330
75	65	6	175 369 065	0.420
90	80	6	175 369 066	0.510
110	100	6	175 369 067	0.710
140	125	6	175 369 069	0.970
160	150	6	175 369 070	1.420
225	200	6	175 369 071	2.710
280	250	6	175 369 072	4.520
315	300	6	175 369 073	6.900

d [mm]	D [mm]	D1 [mm]	D2 [mm]	H [mm]	L [mm]	L1 [mm]	Tightness from water column in m - PVDF [m H ₂ O]	Opening pressure horizontal [mbar]	Number of screws with washer
40	85	59	18	25	15	22	2.0	20	4xM16/90
50	95	72	22	28	16	25	2.0	20	4xM16/95
63	109	86	32	29	18	37	2.0	20	4xM16/110
75	129	105	40	31	20	50	2.0	20	4xM16/140
90	144	119	54	32	20	61	2.0	20	8xM16/150
110	164	146	70	31	23	77	2.0	20	8xM16/160
140	195	173	92	35	23	94	2.0	20	8xM16/180
160	220	197	112	35	26	115	2.0	20	8xM20/200
225	275	255	154	38	35	152	2.0	20	8xM20/220
280	330	312	192	41	40	180	2.0	20	12xM20/240
315	380	363	227	41	45	215	2.0	20	12xM20/260

d [mm]	Torque [Nm]	Number of nut rotations after tightening by hand
40	10	1
50	12	1
63	15	1
75	18	1
90	20	1
110	22	1
140	25	1
160	30	1
225	60	1
280	60	1
315	60	1

PF 2 35 195

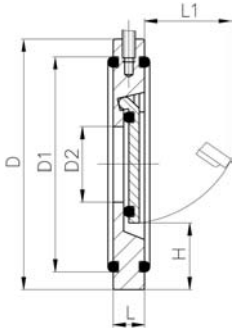

SYGEF® standard Wafer check valve type 369 PVDF With hastelloy C springs

J

Installation instruction:

- Installation between metric flange adaptors with smooth jointing face
- Centering by body diameter
- Supporting eyelets for simple mounting
- Sealing with O-rings
- Suitable for vertical and horizontal mounting
- A stabilizing zone of at least 5 times nominal diameter (DN) should be provided before and after the wafer check valve (10 times DN is recommended)
- No direct installation on pump flange or following bend allowed
- Wafer check valves without reset spring are not recommended for pulsating flows (production of noise)

Note:

- In order to install the wafer check valves properly, Georg Fischer recommends flange adaptors of the next larger diameter of the valve (e.g. wafer check valve d90 with two flange adaptors d110)

d [mm]	DN [mm]	PN	FPM Code	kg
40	32	6	175 369 102	0.170
50	40	6	175 369 103	0.210
63	50	6	175 369 104	0.330
75	65	6	175 369 105	0.420
90	80	6	175 369 106	0.510
110	100	6	175 369 107	0.710
140	125	6	175 369 109	0.970
160	150	6	175 369 110	1.420
225	200	6	175 369 111	2.710
280	250	6	175 369 112	4.520
315	300	6	175 369 113	6.900

d [mm]	D [mm]	D1 [mm]	D2 [mm]	H [mm]	L [mm]	L1 [mm]	Tightness from water column in m - PVDF [m H2O]	Opening pressure horizontal [mbar]	Number of screws with washer
40	85	59	18	25	15	22	2.0	20	4xM16/90
50	95	72	22	28	16	25	2.0	20	4xM16/95
63	109	86	32	29	18	37	2.0	20	4xM16/110
75	129	105	40	31	20	50	2.0	20	4xM16/140
90	144	119	54	32	20	61	2.0	20	8xM16/150
110	164	146	70	31	23	77	2.0	20	8xM16/160
140	195	173	92	35	23	94	2.0	20	8xM16/180
160	220	197	112	35	26	115	2.0	20	8xM20/200
225	275	255	154	38	35	152	2.0	20	8xM20/220
280	330	312	192	41	40	180	2.0	20	12xM20/240
315	380	363	227	41	45	215	2.0	20	12xM20/260

d [mm]	Torque [Nm]	Number of nut rotations after tightening by hand
40	10	1
50	12	1
63	15	1
75	18	1
90	20	1
110	22	1
140	25	1
160	30	1
225	60	1
280	60	1
315	60	1

PF 2 35 195

Ball valves silicon free/paint compatible



DN10/15 - 50

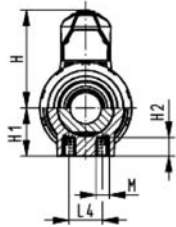
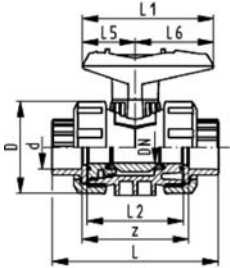

SYGEF® standard oil free Ball valve type 546 OF With fusion sockets metric

Model:

- Oil free
- Ball seals PTFE
- For easy installation and removal
- z-dimension, valve end and valve nut are **not compatible** with type 346 (DN10/15-50) resp. type 370 (DN65-100)
- Integrated stainless steel mounting inserts

Option:

- Individual configuration of the valve (see form)
- Multifunctional module with integrated limit switches

d [mm]	DN [mm]	PN	kv-value ($\Delta p=1$ bar) [l/min]	FPM Code	kg
16	10	16	71	175 546 471	0.195
20	15	16	185	175 546 472	0.200
25	20	16	350	175 546 473	0.300
32	25	16	700	175 546 474	0.440
40	32	16	1000	175 546 475	0.760
50	40	16	1600	175 546 476	1.060
63	50	16	3100	175 546 477	2.055

d [mm]	D [mm]	H [mm]	H1 [mm]	H2 [mm]	L [mm]	L1 [mm]	L2 [mm]	L4 [mm]	L5 [mm]	L6 [mm]	M	z [mm]
16	50	57	27	12	93	77	56	25	32	45	M6	67
20	50	57	27	12	95	77	56	25	32	45	M6	66
25	58	67	30	12	109	97	65	25	39	58	M6	77
32	68	73	36	12	119	97	71	25	39	58	M6	83
40	84	90	44	15	135	128	85	45	54	74	M8	99
50	97	97	51	15	147	128	89	45	54	74	M8	105
63	124	116	64	15	168	152	101	45	66	87	M8	117

PF 2 35 540



DN10/15 - 50

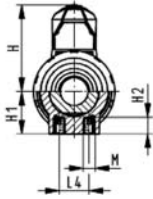
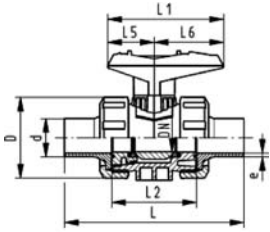

SYGEF® standard silicone free Ball valve type 546 SF With butt fusion spigots IR-Plus metric

J

Model:

- Silicon-free / paint-compatible
- Ball seals PVDF
- For easy installation and removal
- z-dimension, valve end and valve nut are **not compatible** with type 346 (DN10/15-50) resp. type 370 (DN65-100)
- Integrated stainless steel mounting inserts

Option:

- Individual configuration of the valve (see form)
- Multifunctional module with integrated limit switches
- Pneumatic or electric actuators from +GF+

d [mm]	DN [mm]	PN	kv-value ($\Delta p=1$ bar) [l/min]	FPM Code	kg
20	15	16	185	175 546 752	0.205
25	20	16	350	175 546 753	0.310
32	25	16	700	175 546 754	0.460
40	32	16	1000	175 546 755	0.780
50	40	16	1600	175 546 756	1.110
63	50	16	3100	175 546 757	2.150

d [mm]	D [mm]	H [mm]	H1 [mm]	H2 [mm]	L [mm]	L1 [mm]	L2 [mm]	L4 [mm]	L5 [mm]	L6 [mm]	M	e [mm]
20	50	57	27	12	130	77	56	25	32	45	M6	1,9
25	58	67	30	12	143	97	65	25	39	58	M6	1,9
32	68	73	36	12	150	97	71	25	39	58	M6	2,4
40	84	90	44	15	171	128	85	45	54	74	M8	2,4
50	97	97	51	15	191	128	89	45	54	74	M8	3
63	124	116	64	15	220	152	101	45	66	87	M8	3

PF 2 35 540



DN10/15 - 50

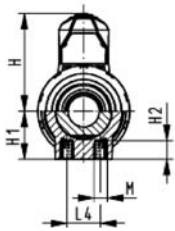
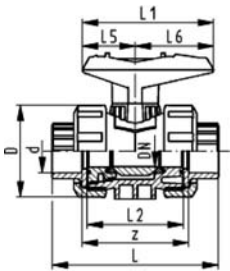

SYGEF® standard silicone free Ball valve type 546 SF With fusion sockets metric

Model:

- Silicon-free / paint-compatible
- Ball seals PVDF
- For easy installation and removal
- z-dimension, valve end and valve nut are **not compatible** with type 346 (DN10/15-50) resp. type 370 (DN65-100)
- Integrated stainless steel mounting inserts

Option:

- Individual configuration of the valve (see form)
- Multifunctional module with integrated limit switches
- Pneumatic or electric actuators from +GF+

d [mm]	DN [mm]	PN	kv-value ($\Delta p=1$ bar) [l/min]	FPM Code	kg
16	10	16	71	175 546 691	0.195
20	15	16	185	175 546 692	0.200
25	20	16	350	175 546 693	0.300
32	25	16	700	175 546 694	0.440
40	32	16	1000	175 546 695	0.760
50	40	16	1600	175 546 696	1.060
63	50	16	3100	175 546 697	2.055

d [mm]	D [mm]	H [mm]	H1 [mm]	H2 [mm]	L [mm]	L1 [mm]	L2 [mm]	L4 [mm]	L5 [mm]	L6 [mm]	M	z [mm]
16	50	79	27	12	93	77	56	25	32	45	M6	67
20	50	57	27	12	95	77	56	25	32	45	M6	66
25	58	67	30	12	109	97	65	25	39	58	M6	77
32	68	73	36	12	119	97	71	25	39	58	M6	83
40	84	90	44	15	135	128	85	45	54	74	M8	99
50	97	97	51	15	147	128	89	45	54	74	M8	105
63	124	116	64	15	168	152	101	45	66	87	M8	117

PF 2 35 540

Ball check valve

75 36 06

SYGEF® standard silicone free Ball check valve type 360 PVDF SF With butt fusion spigots metric

J

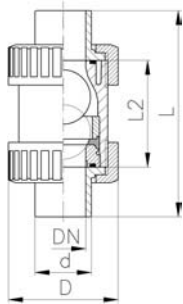

PF 2 37 207

Model:

- For easy installation and removal
- Ball is sealing at a minimum water column of 2 m. Vibration free even at high velocity
- FPM ball seal

Attention; make sure the inner diameter is not reduced by leaving residues of the fusion (danger of turbulence)

d [mm]	DN [mm]	PN	kv-value ($\Delta p=1$ bar) [l/min]	FPM Code	kg	D [mm]	L [mm]	L2 [mm]	
16	10	16	170	175 360 671	0.155	46	109	62	
20	15	16	150	175 360 672	0.156	46	130	62	
25	20	16	330	175 360 673	0.259	56	144	74	
32	25	16	390	175 360 674	0.406	67	150	78	
40	32	16	710	175 360 675	0.676	82	171	88	
50	40	16	900	175 360 676	1.086	98	191	94	
63	50	16	1390	175 360 677	2.029	120	220	113	

75 36 06

SYGEF® standard silicone free Ball check valve type 360 PVDF SF With fusion sockets metric

J

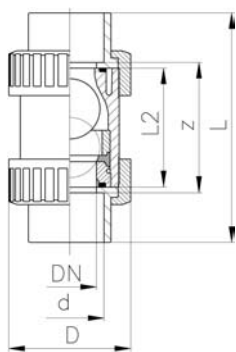

PF 2 37 207

Model:

- For easy installation and removal
- Ball is sealing at a minimum water column of 2 m. Vibration free even at high velocity
- FPM ball seal

Attention; make sure the inner diameter is not reduced by leaving residues of the fusion (danger of turbulence)

d [mm]	DN [mm]	PN	kv-value ($\Delta p=1$ bar) [l/min]	FPM Code	kg	D [mm]	L [mm]	L2 [mm]	z [mm]	
16	10	16	170	175 360 611	0.152	46	98	62	72	
20	15	16	150	175 360 612	0.153	46	101	62	73	
25	20	16	330	175 360 613	0.253	56	119	74	87	
32	25	16	390	175 360 614	0.395	67	130	78	94	
40	32	16	710	175 360 615	0.663	82	149	88	109	
50	40	16	900	175 360 616	1.045	98	162	94	116	
63	50	16	1390	175 360 617	1.960	120	195	113	141	

75 36 06

**SYGEF® standard silicone free
Ball check valve type 360 PVDF SF
With socket fusion spigots metric**

J



Model:

- For easy installation and removal
- Ball is sealing at a minimum water column of 2 m. Vibration free even at high velocity
- FPM ball seal

Attention; make sure the inner diameter is not reduced by leaving residues of the fusion (danger of turbulence)

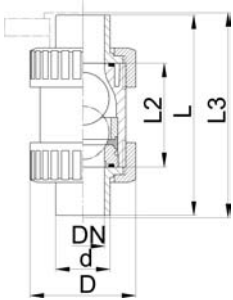

PF 2 37 207

d [mm]	DN [mm]	PN	kv-value ($\Delta p=1$ bar) [l/min]	FPM Code	kg	D [mm]	L [mm]	L1 [mm]	L3 [mm]
16	10	16	170	175 360 631	0.155	46	109	62	120
20	15	16	150	175 360 632	0.156	46	119	62	130
25	20	16	330	175 360 633	0.259	56	140	74	150
32	25	16	390	175 360 634	0.406	67	150	78	160
40	32	16	710	175 360 635	0.676	82	171	88	180
50	40	16	900	175 360 636	1.086	98	191	94	200
63	50	16	1390	175 360 637	2.029	120	220	113	230

Ball valves electric

SYGEF® standard Ball valve type 107 100-230V With manual emergency override With butt fusion spigots metric

E



DN10/15 - 50

Model:

- Built on with electric actuator EA11
- Voltage 100-230 V, 50-60 Hz
- Control range 90°<
- Control time 5 s/90°<
- For easy installation and removal
- Integrated stainless steel mounting inserts

Option:

- Individual configuration of the valve (see form)

d [mm]	DN [mm]	PN	kv-value ($\Delta p=1$ bar) [l/min]	FPM Code
20	15	10	185	199 107 423
25	20	10	350	199 107 424
32	25	10	700	199 107 425
40	32	10	1000	199 107 426
50	40	10	1600	199 107 427
63	50	10	3100	199 107 428

d [mm]	D [mm]	H [mm]	H1 [mm]	H2 [mm]	H3 [mm]	H5 [mm]	L [mm]	L1 [mm]	L2 [mm]	L4 [mm]	L5 [mm]	L6 [mm]	L7 [mm]	L8 [mm]
20	50	200	27	64	64	137	130	161	56	25	79	83	122	67
25	58	209	30	73	64	137	143	161	65	25	79	83	122	67
32	68	209	36	73	64	137	150	161	71	25	79	83	122	67
40	84	220	44	84	64	137	171	161	85	45	79	83	122	67
50	97	220	51	84	64	137	191	161	89	45	79	83	122	67
63	124	243	64	106	64	137	220	161	101	45	79	83	122	67

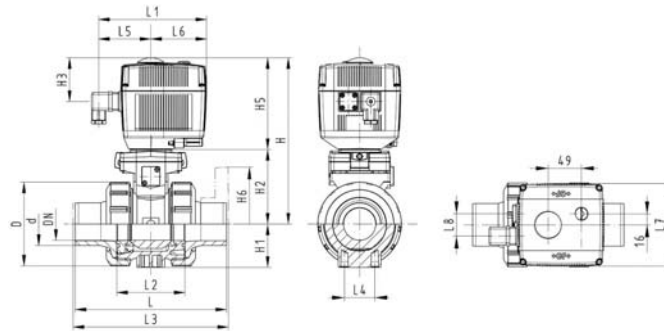

PF 3 39 695



DN10/15 - 50

SYGEF® standard Ball valve type 107 100-230V With manual emergency override With fusion sockets metric

E

Model:

- Built on with electric actuator EA11
- Voltage 100-230 V, 50-60 Hz
- Control range 90°<
- Control time 5 s/90°<
- For easy installation and removal
- Integrated stainless steel mounting inserts

Option:

- Individual configuration of the valve (see form)

d [mm]	DN [mm]	PN	kv-value ($\Delta p=1$ bar) [l/min]	FPM Code	kg
16	10	10	70	199 107 802	2.100
20	15	10	185	199 107 803	2.100
25	20	10	350	199 107 804	2.200
32	25	10	700	199 107 805	2.300
40	32	10	1000	199 107 806	2.600
50	40	10	1600	199 107 807	3.000
63	50	10	3100	199 107 808	3.800

d [mm]	D [mm]	H [mm]	H1 [mm]	H2 [mm]	H3 [mm]	H5 [mm]	L [mm]	L1 [mm]	L2 [mm]	L4 [mm]	L5 [mm]	L6 [mm]	L7 [mm]	L8 [mm]	z [mm]
16	50	200	27	64	64	137	92	161	56	25	79	83	122	67	64
20	50	200	27	64	64	137	95	161	56	25	79	83	122	67	64
25	58	209	30	73	64	137	110	161	65	25	79	83	122	67	72
32	68	209	36	73	64	137	123	161	71	25	79	83	122	67	79
40	84	220	44	84	64	137	146	161	85	45	79	83	122	67	94
50	97	220	51	84	64	137	157	161	89	45	79	83	122	67	95
63	124	243	64	106	64	137	183	161	101	45	79	83	122	67	107

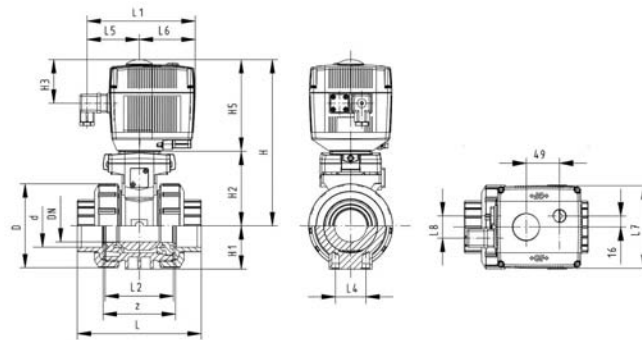

PF 3 39 695

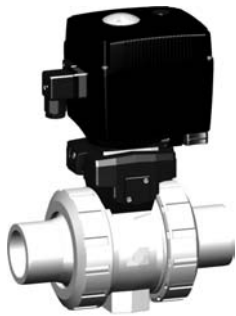

DN10/15 - 50

SYGEF® standard Ball valve type 107 100-230V With manual emergency override With fusion spigots metric

E

Model:

- Built on with electric actuator EA11
- Voltage 100-230 V, 50-60 Hz
- Control range 90°<
- Control time 5 s/90°<
- For easy installation and removal
- Integrated stainless steel mounting inserts

Option:

- Individual configuration of the valve (see form)

d [mm]	DN [mm]	PN	kv-value ($\Delta p=1$ bar) [l/min]	FPM Code	kg
16	10	10	70	199 107 812	2.100
20	15	10	185	199 107 813	2.100
25	20	10	350	199 107 814	2.200
32	25	10	700	199 107 815	2.300
40	32	10	1000	199 107 816	2.600
50	40	10	1600	199 107 817	3.000
63	50	10	3100	199 107 818	3.800

d [mm]	D [mm]	H [mm]	H1 [mm]	H2 [mm]	H3 [mm]	H5 [mm]	L [mm]	L1 [mm]	L2 [mm]	L3 [mm]	L4 [mm]	L5 [mm]	L6 [mm]	L7 [mm]	L8 [mm]
16	50	200	27	64	64	137	114	161	56	0	25	79	83	122	67
20	50	200	27	64	64	137	124	161	56	130	25	79	83	122	67
25	58	209	30	73	64	137	144	161	65	150	25	79	83	122	67
32	68	209	36	73	64	137	154	161	71	160	25	79	83	122	67
40	84	220	44	84	64	137	174	161	85	180	45	79	83	122	67
50	97	220	51	84	64	137	194	161	89	200	45	79	83	122	67
63	124	243	64	106	64	137	224	161	101	230	45	79	83	122	67

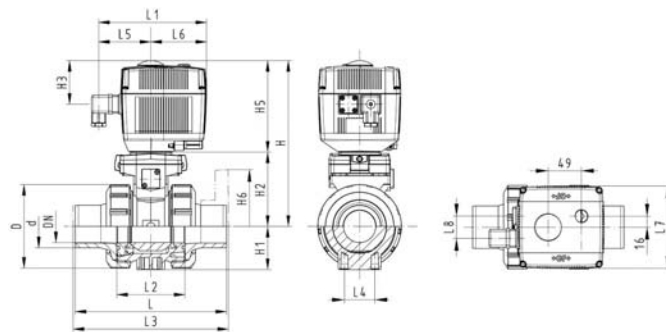

PF 3 39 695

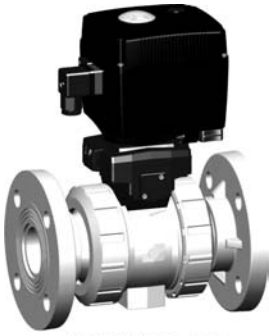

DN10/15 - 50

SYGEF® standard
Ball valve type 107 100-230V
With manual emergency override
With fixed flanges PVDF serrated metric

E

Model:

- Built on with electric actuator EA11
- Voltage 100-230 V, 50-60 Hz
- Control range 90°<
- Control time 5 s/90°<
- For easy installation and removal
- Integrated stainless steel mounting inserts
- Overall length EN 558-1
- Connecting dimensions: ISO 7005 / EN 1092 / DIN 2501 PN10 / BS4504

Option:

- Individual configuration of the valve (see form)

d [mm]	DN [mm]	Inch	PN	kv-value ($\Delta p=1$ bar) [l/min]	FPM Code	kg
20	15	½	10	185	199 107 843	2.300
25	20	¾	10	350	199 107 844	2.500
32	25	1	10	700	199 107 845	2.700
40	32	1 ¼	10	1000	199 107 846	3.200
50	40	1 ½	10	1600	199 107 847	3.700
63	50	2	10	3100	199 107 848	4.800

d [mm]	D [mm]	H [mm]	H1 [mm]	H2 [mm]	H3 [mm]	H5 [mm]	H6 [mm]	L [mm]	L1 [mm]	L2 [mm]	L3 [mm]	L4 [mm]	L5 [mm]	L6 [mm]	L7 [mm]
20	50	201	27	64	65	138	48	124	160	56	130	25	77	83	122
25	58	210	30	73	65	138	53	144	160	65	150	25	77	83	122
32	68	210	36	73	65	138	58	154	160	71	160	25	77	83	122
40	84	221	44	84	65	138	70	174	160	85	180	45	77	83	122
50	97	221	51	84	65	138	75	194	160	89	200	45	77	83	122
63	124	244	64	106	65	138	83	224	160	101	230	45	77	83	122

d [mm]	L8 [mm]
20	33
25	33
32	33
40	33
50	33
63	33

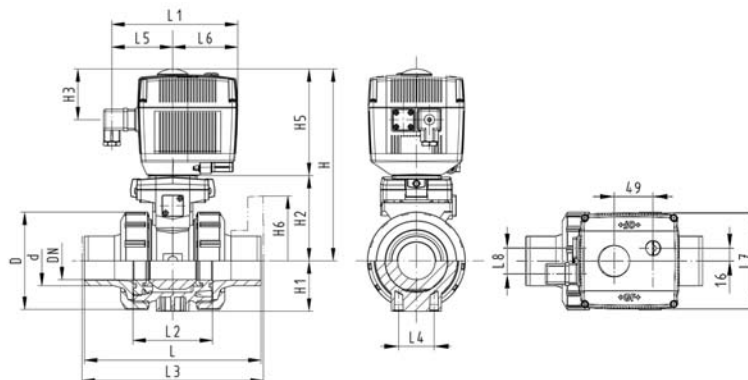

PF 3 39 695



DN10/15 - 50

SYGEF® standard

Ball valve type 107 24V

With manual emergency override

With butt fusion spigots metric

E

Model:

- Built on with electric actuator EA11
- Voltage 24 V AC/DC
- Control range 90°<
- Control time 5 s/90°<
- For easy installation and removal
- Integrated stainless steel mounting inserts

Option:

- Individual configuration of the valve (see form)

d [mm]	DN [mm]	PN	kv-value ($\Delta p=1$ bar) [l/min]	FPM Code
20	15	10	185	199 107 433
25	20	10	350	199 107 434
32	25	10	700	199 107 435
40	32	10	1000	199 107 436
50	40	10	1600	199 107 437
63	50	10	3100	199 107 438

d [mm]	D [mm]	H [mm]	H1 [mm]	H2 [mm]	H3 [mm]	H5 [mm]	L [mm]	L1 [mm]	L2 [mm]	L4 [mm]	L5 [mm]	L6 [mm]	L7 [mm]	L8 [mm]
20	50	200	27	64	64	137	130	161	56	25	79	83	122	67
25	58	209	30	73	64	137	143	161	65	25	79	83	122	67
32	68	209	36	73	64	137	150	161	71	25	79	83	122	67
40	84	220	44	84	64	137	171	161	85	45	79	83	122	67
50	97	220	51	84	64	137	191	161	89	45	79	83	122	67
63	124	243	64	106	64	137	220	161	101	45	79	83	122	67

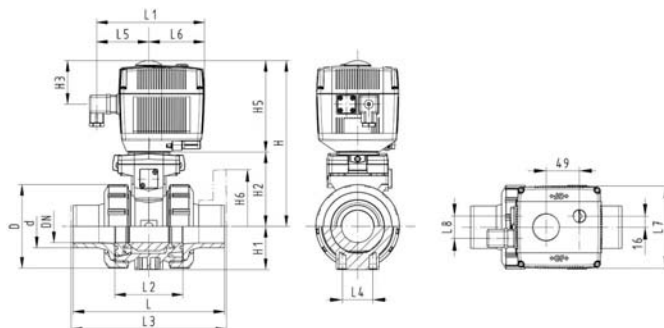

PF 3 39 695



DN10/15 - 50

SYGEF® standard Ball valve type 107 24V With manual emergency override With fusion sockets metric

E

Model:

- Built on with electric actuator EA11
- Voltage 24 V AC/DC
- Control range 90°<
- Control time 5 s/90°<
- For easy installation and removal
- Integrated stainless steel mounting inserts

Option:

- Individual configuration of the valve (see form)

d [mm]	DN [mm]	PN	kv-value ($\Delta p=1$ bar) [l/min]	FPM Code	kg
16	10	10	70	199 107 822	2.100
20	15	10	185	199 107 823	2.100
25	20	10	350	199 107 824	2.200
32	25	10	700	199 107 825	2.300
40	32	10	1000	199 107 826	2.600
50	40	10	1600	199 107 827	3.000
63	50	10	3100	199 107 828	3.800

d [mm]	D [mm]	H [mm]	H1 [mm]	H2 [mm]	H3 [mm]	H5 [mm]	L [mm]	L1 [mm]	L2 [mm]	L4 [mm]	L5 [mm]	L6 [mm]	L7 [mm]	L8 [mm]	z [mm]
16	50	200	27	64	64	137	92	161	56	25	79	83	122	67	64
20	50	200	27	64	64	137	95	161	56	25	79	83	122	67	64
25	58	209	30	73	64	137	110	161	65	25	79	83	122	67	72
32	68	209	36	73	64	137	123	161	71	25	79	83	122	67	79
40	84	220	44	84	64	137	146	161	85	45	79	83	122	67	94
50	97	220	51	84	64	137	157	161	89	45	79	83	122	67	95
63	124	243	64	106	64	137	183	161	101	45	79	83	122	67	107

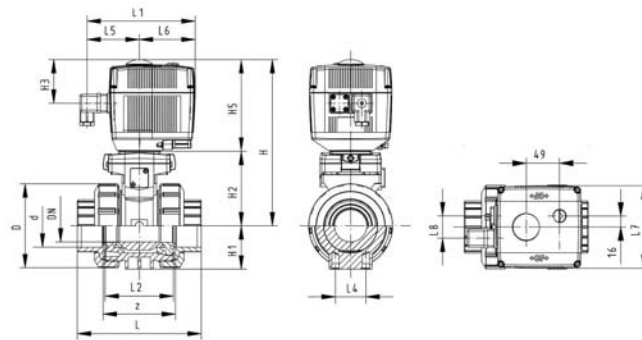

PF 3 39 695



DN10/15 - 50

SYGEF® standard Ball valve type 107 24V With manual emergency override With fusion spigots metric

E

Model:

- Built on with electric actuator EA11
- Voltage 24 V AC/DC
- Control range 90°<
- Control time 5 s/90°<
- For easy installation and removal
- Integrated stainless steel mounting inserts

Option:

- Individual configuration of the valve (see form)

d [mm]	DN [mm]	PN	kv-value ($\Delta p=1$ bar) [l/min]	FPM Code	kg
16	10	10	70	199 107 832	2.100
20	15	10	185	199 107 833	2.100
25	20	10	350	199 107 834	2.200
32	25	10	700	199 107 835	2.300
40	32	10	1000	199 107 836	2.600
50	40	10	1600	199 107 837	3.000
63	50	10	3100	199 107 838	3.800

d [mm]	D [mm]	H [mm]	H1 [mm]	H2 [mm]	H3 [mm]	H5 [mm]	L [mm]	L1 [mm]	L2 [mm]	L3 [mm]	L4 [mm]	L5 [mm]	L6 [mm]	L7 [mm]	L8 [mm]
16	50	200	27	64	64	137	114	161	56	0	25	79	83	122	67
20	50	200	27	64	64	137	124	161	56	130	25	79	83	122	67
25	58	209	30	73	64	137	144	161	65	150	25	79	83	122	67
32	68	209	36	73	64	137	154	161	71	160	25	79	83	122	67
40	84	220	44	84	64	137	174	161	85	180	45	79	83	122	67
50	97	220	51	84	64	137	194	161	89	200	45	79	83	122	67
63	124	243	64	106	64	137	224	161	101	230	45	79	83	122	67

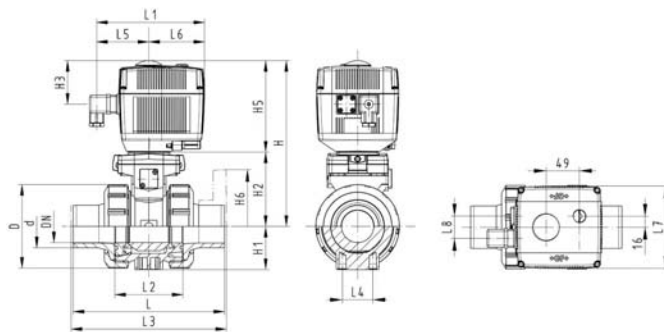

PF 3 39 695

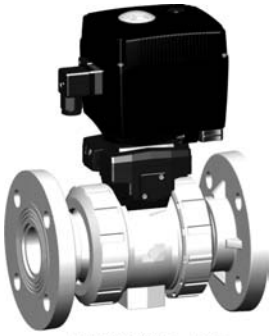

DN10/15 - 50

SYGEF® standard Ball valve type 107 24V With manual emergency override With fixed flanges PVDF serrated metric

E

Model:

- Built on with electric actuator EA11
- Voltage 24 V AC/DC
- Control range 90°<
- Control time 5 s/90°<
- For easy installation and removal
- Integrated stainless steel mounting inserts
- Overall length EN 558-1
- Connecting dimensions: ISO 7005 / EN 1092 / DIN 2501 PN10 / BS4504

Option:

- Individual configuration of the valve (see form)

d [mm]	DN [mm]	Inch	PN	kv-value ($\Delta p=1$ bar) [l/min]	FPM Code	kg
20	15	½	10	185	199 107 853	2.300
25	20	¾	10	350	199 107 854	2.500
32	25	1	10	700	199 107 855	2.700
40	32	1 ¼	10	1000	199 107 856	3.200
50	40	1 ½	10	1600	199 107 857	3.700
63	50	2	10	3100	199 107 858	4.800

d [mm]	D [mm]	H [mm]	H1 [mm]	H2 [mm]	H3 [mm]	H5 [mm]	H6 [mm]	L [mm]	L1 [mm]	L2 [mm]	L3 [mm]	L4 [mm]	L5 [mm]	L6 [mm]	L7 [mm]
20	50	201	27	64	65	138	48	124	160	56	130	25	77	83	122
25	58	210	30	73	65	138	53	144	160	65	150	25	77	83	122
32	68	210	36	73	65	138	58	154	160	71	160	25	77	83	122
40	84	221	44	84	65	138	70	174	160	85	180	45	77	83	122
50	97	221	51	84	65	138	75	194	160	89	200	45	77	83	122
63	124	244	64	106	65	138	83	224	160	101	230	45	77	83	122

d [mm]	L8 [mm]
20	33
25	33
32	33
40	33
50	33
63	33

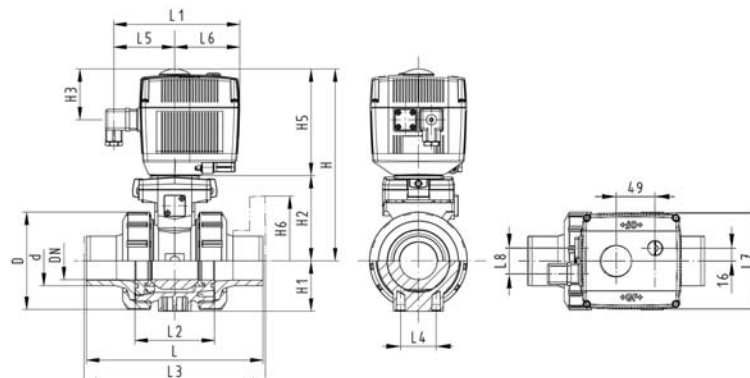

PF 3 39 695



DN10/15 - 50

SYGEF® standard Ball valve type 132 100-230V With manual emergency override With butt fusion spigots metric

E

Model:

- Assignment of actuators EA21 (DN10/15-50), EA31 (DN65-100 if available)
- Voltage 100-230 V, 50-60 Hz
- Control range 90°<
- Control time 5 s/90°<
- For easy installation and removal
- Integrated stainless steel mounting inserts

Option:

- Individual configuration of the valve (see form)

d [mm]	DN [mm]	PN	kv-value ($\Delta p=1$ bar) [l/min]	FPM Code
20	15	10	185	199 132 113
25	20	10	350	199 132 114
32	25	10	700	199 132 115
40	32	10	1000	199 132 116
50	40	10	1600	199 132 117
63	50	10	3100	199 132 118

d [mm]	D [mm]	H [mm]	H1 [mm]	H2 [mm]	H3 [mm]	H5 [mm]	L [mm]	L1 [mm]	L2 [mm]	L4 [mm]	L5 [mm]	L6 [mm]	L7 [mm]	L8 [mm]
20	50	231	27	64	94	167	130	180	56	25	97	83	122	66
25	58	240	30	73	94	167	143	180	65	25	97	83	122	66
32	68	240	36	73	94	167	150	180	71	25	97	83	122	66
40	84	251	44	84	94	167	171	180	85	45	97	83	122	66
50	97	251	51	84	94	167	191	180	89	45	97	83	122	66
63	124	273	64	106	94	167	220	180	101	45	97	83	122	66

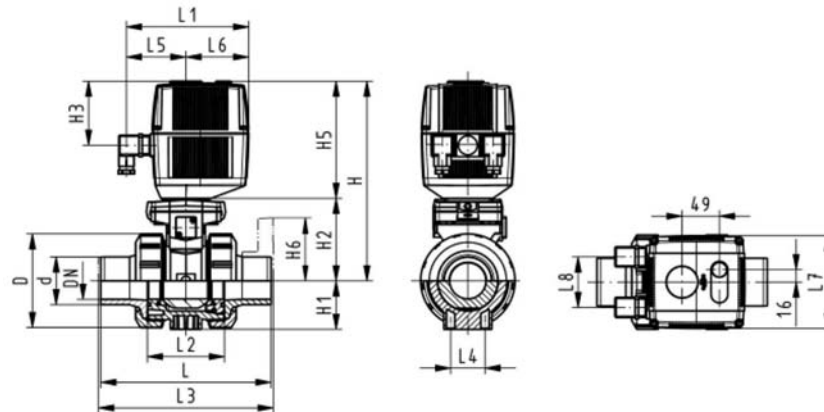

PF 3 39 695

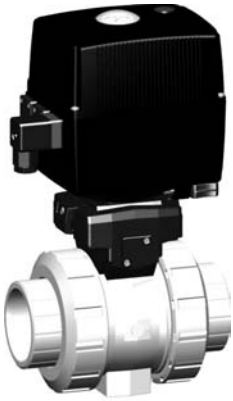

DN10/15 - 50

SYGEF® standard

Ball valve type 132 100-230V

With manual emergency override

With fusion sockets metric

E

Model:

- Assignment of actuators EA21 (DN10/15-50), EA31 (DN65-100 if available)
- Voltage 100-230 V, 50-60 Hz
- Control range 90°<
- Control time 5 s/90°<
- For easy installation and removal
- Integrated stainless steel mounting inserts

Option:

- Individual configuration of the valve (see form)

d [mm]	DN [mm]	PN	kv-value ($\Delta p=1$ bar) [l/min]	FPM Code	kg
16	10	10	70	199 132 012	2.100
20	15	10	185	199 132 013	2.100
25	20	10	350	199 132 014	2.200
32	25	10	700	199 132 015	2.300
40	32	10	1000	199 132 016	2.600
50	40	10	1600	199 132 017	3.000
63	50	10	3100	199 132 018	3.800

d [mm]	D [mm]	H [mm]	H1 [mm]	H2 [mm]	H3 [mm]	H5 [mm]	L [mm]	L1 [mm]	L2 [mm]	L4 [mm]	L5 [mm]	L6 [mm]	L7 [mm]	L8 [mm]	z [mm]
16	50	231	27	64	94	167	92	180	56	25	97	83	122	66	64
20	50	231	27	64	94	167	95	180	56	25	97	83	122	66	64
25	58	240	30	73	94	167	110	180	65	25	97	83	122	66	72
32	68	240	36	73	94	167	123	180	71	25	97	83	122	66	79
40	84	251	44	84	94	167	146	180	85	45	97	83	122	66	94
50	97	251	51	84	94	167	157	180	89	45	97	83	122	66	95
63	124	273	64	106	94	167	183	180	101	45	97	83	122	66	107

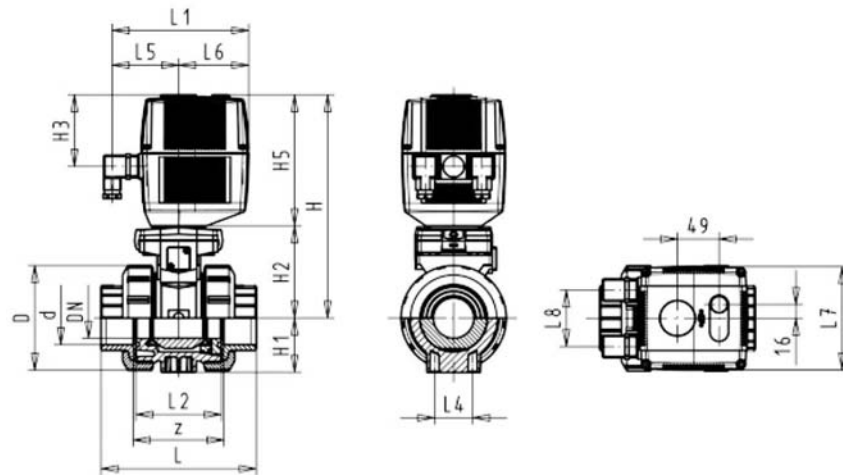

PF 3 39 695



DN10/15 - 50

SYGEF® standard Ball valve type 132 100-230V With manual emergency override With fusion spigots metric

E

Model:

- Assignment of actuators EA21 (DN10/15-50), EA31 (DN65-100 if available)
- Voltage 100-230 V, 50-60 Hz
- Control range 90°<
- Control time 5 s/90°<
- For easy installation and removal
- Integrated stainless steel mounting inserts

Option:

- Individual configuration of the valve (see form)

d [mm]	DN [mm]	PN	kv-value ($\Delta p=1$ bar) [l/min]	FPM Code	kg
16	10	10	70	199 132 032	2.100
20	15	10	185	199 132 033	2.100
25	20	10	350	199 132 034	2.200
32	25	10	700	199 132 035	2.300
40	32	10	1000	199 132 036	2.600
50	40	10	1600	199 132 037	3.000
63	50	10	3100	199 132 038	3.800

d [mm]	D [mm]	H [mm]	H1 [mm]	H2 [mm]	H3 [mm]	H5 [mm]	L [mm]	L1 [mm]	L2 [mm]	L3 [mm]	L4 [mm]	L5 [mm]	L6 [mm]	L7 [mm]	L8 [mm]
16	50	231	27	64	94	167	114	180	56	130	25	97	83	122	66
20	50	231	27	64	94	167	124	180	56	130	25	97	83	122	66
25	58	240	30	73	94	167	144	180	65	150	25	97	83	122	66
32	68	240	36	73	94	167	154	180	71	160	25	97	83	122	66
40	84	251	44	84	94	167	174	180	85	180	45	97	83	122	66
50	97	251	51	84	94	167	194	180	89	200	45	97	83	122	66
63	124	273	64	106	94	167	224	180	101	230	45	97	83	122	66

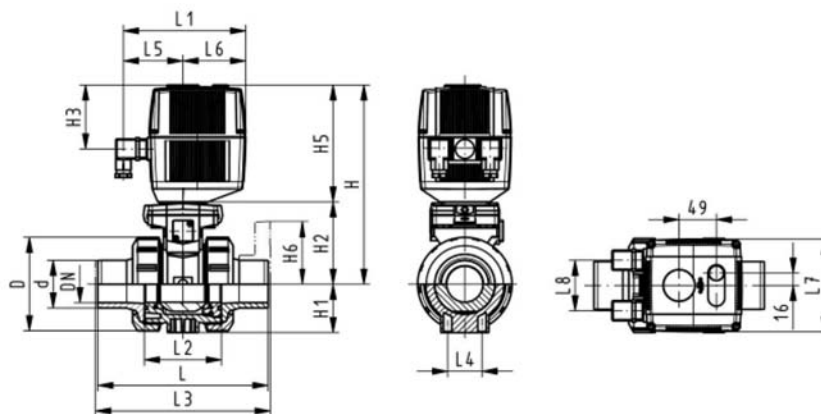

PF 3 39 695

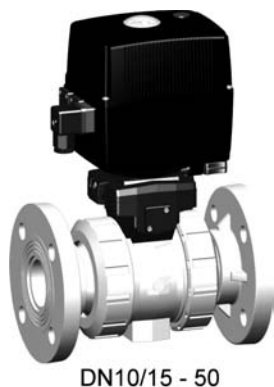

SYGEF® standard
Ball valve type 132 100-230V
With manual emergency override
With fixed flanges PVDF serrated metric

E

Model:

- Assignment of actuators EA21 (DN10/15-50), EA31 (DN65-100 if available)
- Voltage 100-230 V, 50-60 Hz
- Control range 90°<
- Control time 5 s/90°<
- For easy installation and removal
- Integrated stainless steel mounting inserts
- Overall length EN 558-1
- Connecting dimensions: ISO 7005 / EN 1092 / DIN 2501 PN10 / BS4504

Option:

- Individual configuration of the valve (see form)

d [mm]	DN [mm]	Inch	PN	kv-value ($\Delta p=1$ bar) [l/min]	FPM Code	kg
20	15	½	10	185	199 132 083	2.300
25	20	¾	10	350	199 132 084	2.500
32	25	1	10	700	199 132 085	2.700
40	32	1 ¼	10	1000	199 132 086	3.200
50	40	1 ½	10	1600	199 132 087	3.700
63	50	2	10	3100	199 132 088	4.800

d [mm]	D [mm]	H [mm]	H1 [mm]	H2 [mm]	H3 [mm]	H5 [mm]	H6 [mm]	L [mm]	L1 [mm]	L2 [mm]	L3 [mm]	L4 [mm]	L5 [mm]	L6 [mm]	L7 [mm]
20	50	231	27	64	94	167	48	124	180	56	130	25	98	83	122
25	58	240	30	73	94	167	53	144	180	65	150	25	97	83	122
32	68	240	36	73	94	167	58	154	180	71	160	25	97	83	122
40	84	251	44	84	94	167	70	174	180	85	180	45	97	83	122
50	97	251	51	84	94	167	75	194	180	89	200	45	98	83	122
63	124	273	64	106	94	167	83	224	180	101	230	45	97	83	122

d [mm]	L8 [mm]
20	66
25	66
32	66
40	66
50	66
63	66

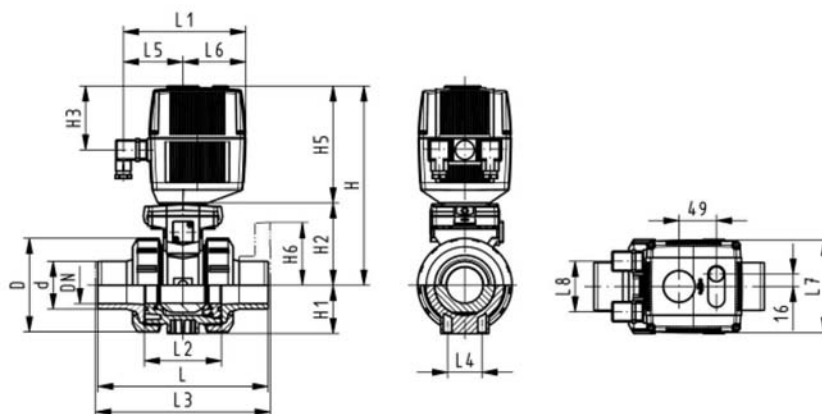

PF 3 39 695



DN10/15 - 50

SYGEF® standard Ball valve type 132 24V With manual emergency override With butt fusion spigots metric

E

Model:

- Assignment of actuators EA21 (DN10/15-50), EA31 (DN65-100 if available)
- Voltage 24 V AC/DC
- Control range 90°<
- Control time 5 s/90°<
- For easy installation and removal
- Integrated stainless steel mounting inserts

Option:

- Individual configuration of the valve (see form)

d [mm]	DN [mm]	PN	kv-value ($\Delta p=1$ bar) [l/min]	FPM Code
20	15	10	185	199 132 153
25	20	10	350	199 132 154
32	25	10	700	199 132 155
40	32	10	1000	199 132 156
50	40	10	1600	199 132 157
63	50	10	3100	199 132 158

d [mm]	D [mm]	H [mm]	H1 [mm]	H2 [mm]	H3 [mm]	H5 [mm]	L [mm]	L1 [mm]	L2 [mm]	L4 [mm]	L5 [mm]	L6 [mm]	L7 [mm]	L8 [mm]
20	50	231	27	64	94	167	130	180	56	25	97	83	122	66
25	58	240	30	73	94	167	143	180	65	25	97	83	122	66
32	68	240	36	73	94	167	150	180	71	25	97	83	122	66
40	84	251	44	84	94	167	171	180	85	45	97	83	122	66
50	97	251	51	84	94	167	191	180	89	45	97	83	122	66
63	124	273	64	106	94	167	220	180	101	45	97	83	122	66

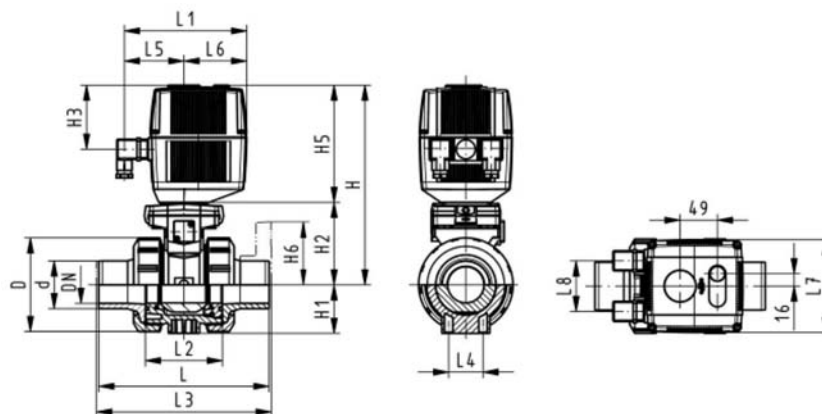

PF 3 39 695

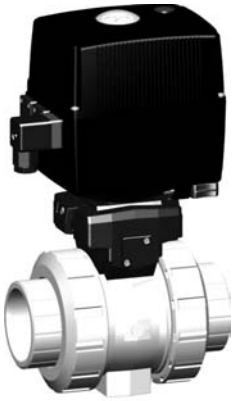

DN10/15 - 50

SYGEF® standard Ball valve type 132 24V With manual emergency override With fusion sockets metric

E

Model:

- Assignment of actuators EA21 (DN10/15-50), EA31 (DN65-100 if available)
- Voltage 24 V AC/DC
- Control range 90°<
- Control time 5 s/90°<
- For easy installation and removal
- Integrated stainless steel mounting inserts

Option:

- Individual configuration of the valve (see form)

d [mm]	DN [mm]	PN	kv-value ($\Delta p=1$ bar) [l/min]	FPM Code	kg
16	10	10	70	199 132 052	2.100
20	15	10	185	199 132 053	2.100
25	20	10	350	199 132 054	2.200
32	25	10	700	199 132 055	2.300
40	32	10	1000	199 132 056	2.600
50	40	10	1600	199 132 057	3.000
63	50	10	3100	199 132 058	3.800

d [mm]	D [mm]	H [mm]	H1 [mm]	H2 [mm]	H3 [mm]	H5 [mm]	L [mm]	L1 [mm]	L2 [mm]	L4 [mm]	L5 [mm]	L6 [mm]	L7 [mm]	L8 [mm]	z [mm]
16	50	231	27	64	94	167	92	180	56	25	97	83	122	66	64
20	50	231	27	64	94	167	95	180	56	25	97	83	122	66	64
25	58	240	30	73	94	167	110	180	65	25	97	83	122	66	72
32	68	240	36	73	94	167	123	180	71	25	97	83	122	66	79
40	84	251	44	84	94	167	146	180	85	45	97	83	122	66	94
50	97	251	51	84	94	167	157	180	89	45	97	83	122	66	95
63	124	273	64	106	94	167	183	180	101	45	97	83	122	66	107

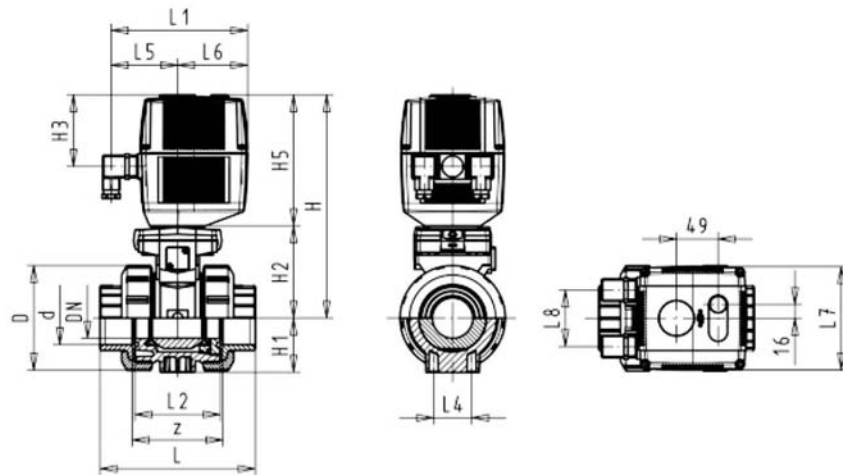

PF 3 39 695



DN10/15 - 50

SYGEF® standard Ball valve type 132 24V With manual emergency override With fusion spigots metric

E

Model:

- Assignment of actuators EA21 (DN10/15-50), EA31 (DN65-100 if available)
- Voltage 24 V AC/DC
- Control range 90°<
- Control time 5 s/90°<
- For easy installation and removal
- Integrated stainless steel mounting inserts

Option:

- Individual configuration of the valve (see form)

d [mm]	DN [mm]	PN	kv-value ($\Delta p=1$ bar) [l/min]	FPM Code	kg
16	10	10	70	199 132 072	2.100
20	15	10	185	199 132 073	2.100
25	20	10	350	199 132 074	2.200
32	25	10	700	199 132 075	2.300
40	32	10	1000	199 132 076	2.600
50	40	10	1600	199 132 077	3.000
63	50	10	3100	199 132 078	3.800

d [mm]	D [mm]	H [mm]	H1 [mm]	H2 [mm]	H3 [mm]	H5 [mm]	L [mm]	L1 [mm]	L2 [mm]	L3 [mm]	L4 [mm]	L5 [mm]	L6 [mm]	L7 [mm]	L8 [mm]
16	50	231	27	64	94	167	114	180	56	130	25	97	83	122	66
20	50	231	27	64	94	167	124	180	56	130	25	97	83	122	66
25	58	240	30	73	94	167	144	180	65	150	25	97	83	122	66
32	68	240	36	73	94	167	154	180	71	160	25	97	83	122	66
40	84	251	44	84	94	167	174	180	85	180	45	97	83	122	66
50	97	251	51	84	94	167	194	180	89	200	45	97	83	122	66
63	124	273	64	106	94	167	224	180	101	230	45	97	83	122	66

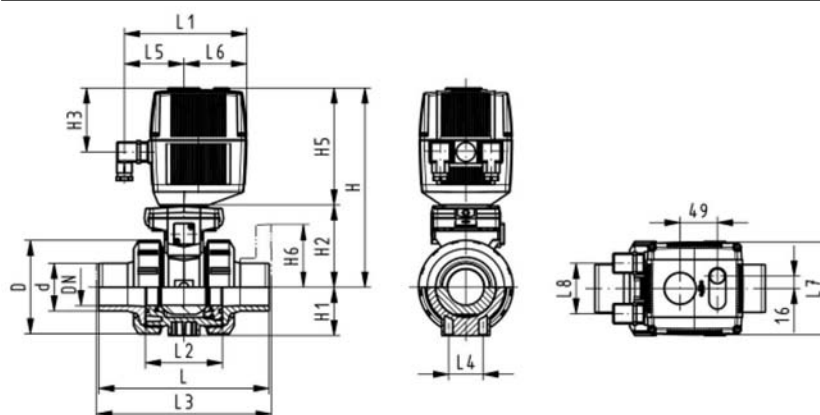

PF 3 39 695

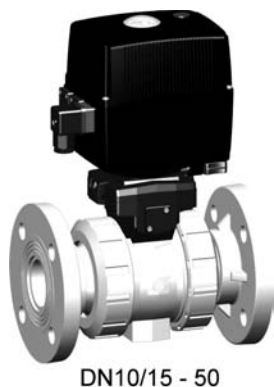

SYGEF® standard

Ball valve type 132 24V

With manual emergency override

With fixed flanges PVDF serrated metric

E

Model:

- Assignment of actuators EA21 (DN10/15-50), EA31 (DN65-100 if available)
- Voltage 24 V AC/DC
- Control range 90°<
- Control time 5 s/90°<
- For easy installation and removal
- Integrated stainless steel mounting inserts
- Overall length EN 558-1
- Connecting dimensions: ISO 7005 / EN 1092 / DIN 2501 PN10 / BS4504

Option:

- Individual configuration of the valve (see form)

d [mm]	DN [mm]	Inch	PN	kv-value ($\Delta p=1$ bar) [l/min]	FPM Code	kg
20	15	½	10	185	199 132 093	2.300
25	20	¾	10	350	199 132 094	2.500
32	25	1	10	700	199 132 095	2.700
40	32	1 ¼	10	1000	199 132 096	3.200
50	40	1 ½	10	1600	199 132 097	3.700
63	50	2	10	3100	199 132 098	4.800

d [mm]	D [mm]	H [mm]	H1 [mm]	H2 [mm]	H3 [mm]	H5 [mm]	H6 [mm]	L [mm]	L1 [mm]	L2 [mm]	L3 [mm]	L4 [mm]	L5 [mm]	L6 [mm]	L7 [mm]
20	50	231	27	64	94	167	48	124	180	56	130	25	98	83	122
25	58	240	30	73	94	167	53	144	180	65	150	25	97	83	122
32	68	240	36	73	94	167	58	154	180	71	160	25	97	83	122
40	84	251	44	84	94	167	70	174	180	85	180	45	97	83	122
50	97	251	51	84	94	167	75	194	180	89	200	45	98	83	122
63	124	273	64	106	94	167	83	224	180	101	230	45	97	83	122

d [mm]	L8 [mm]
20	66
25	66
32	66
40	66
50	66
63	66

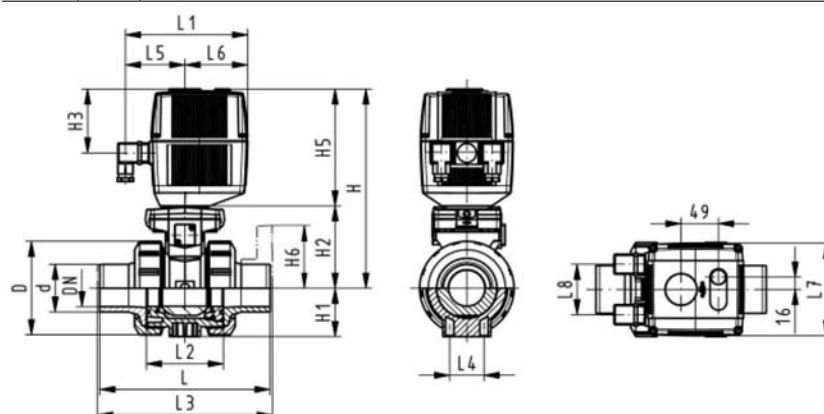

PF 3 39 695



SYGEF® standard
3-Way ball valve type 177
Horizontal/L-port 100-230V
With manual emergency override
With butt fusion spigots IR metric

Model:

- Assignment of actuators EA21 (DN10/15-50), EA31 (DN65-100 if available)
- Voltage 100-230 V, 50-60 Hz
- Control range 90°<
- Control time 5 s/90°<
- For easy installation and removal
- Integrated stainless steel mounting inserts

d [mm]	DN [mm]	PN	kv-value ($\Delta p=1$ bar) [l/min]	FPM Code	kg
16	10	10	50	199 177 052	2.178
20	15	10	75	199 177 053	2.461
25	20	10	150	199 177 054	2.408
32	25	10	280	199 177 055	2.474
40	32	10	480	199 177 056	3.053
50	40	10	620	199 177 057	3.744
63	50	10	1230	199 177 058	5.468

d [mm]	D [mm]	H [mm]	H1 [mm]	H2 [mm]	H3 [mm]	H5 [mm]	H6 [mm]	L [mm]	L1 [mm]	L2 [mm]	L3 [mm]	L4 [mm]	L5 [mm]	L6 [mm]	L7 [mm]
16	46	197	29	31	93	166	8	119	182	70	36	25	99	83	122
20	46	197	29	31	93	166	8	133	182	70	36	25	99	83	122
25	56	205	33	39	93	166	8	155	182	86	43	25	99	83	122
32	67	210	38	44	93	166	8	170	182	96	48	25	99	83	122
40	82	216	44	50	93	166	9	201	182	114	58	45	99	83	122
50	98	229	50	63	93	166	9	236	182	137	69	45	99	83	122
63	121	242	61	76	93	166	9	286	182	179	90	45	99	83	122

d [mm]	L8 [mm]	M
16	33	6
20	33	6
25	33	6
32	33	6
40	33	8
50	33	8
63	33	8

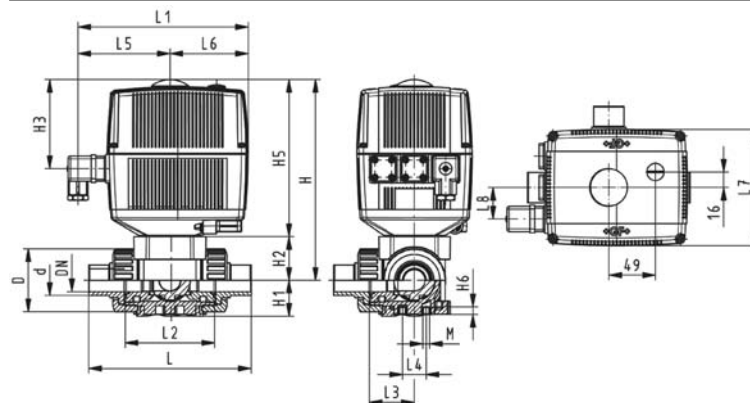

PF 3 39 749



SYGEF® standard
3-Way ball valve type 177
Horizontal/L-port 100-230V
With manual emergency override
With fusion sockets

Model:

- Assignment of actuators EA21 (DN10/15-50), EA31 (DN65-100 if available)
- Voltage 100-230 V, 50-60 Hz
- Control range 90°<
- Control time 5 s/90°<
- For easy installation and removal
- Integrated stainless steel mounting inserts

d [mm]	DN [mm]	PN	kv-value ($\Delta p=1$ bar) [l/min]	FPM Code	kg
16	10	10	50	199 177 092	2.200
20	15	10	75	199 177 093	2.121
25	20	10	150	199 177 094	2.408
32	25	10	280	199 177 095	2.618
40	32	10	480	199 177 096	3.053
50	40	10	620	199 177 097	3.744
63	50	10	1230	199 177 098	5.468

d [mm]	D [mm]	H [mm]	H1 [mm]	H2 [mm]	H3 [mm]	H5 [mm]	H6 [mm]	L [mm]	L1 [mm]	L2 [mm]	L3 [mm]	L4 [mm]	L5 [mm]	L6 [mm]	L7 [mm]
16	46	197	29	31	93	166	8	119	182	70	36	25	99	83	122
20	46	197	29	31	93	166	8	133	182	70	36	25	99	83	122
25	56	205	33	39	93	166	8	155	182	86	43	25	99	83	122
32	67	210	38	44	93	166	8	170	182	96	48	25	99	83	122
40	82	216	44	50	93	166	9	201	182	114	58	45	99	83	122
50	98	229	50	63	93	166	9	236	182	137	69	45	99	83	122
63	121	242	61	76	93	166	9	286	182	179	90	45	99	83	122

d [mm]	L8 [mm]	M
16	33	6
20	33	6
25	33	6
32	33	6
40	33	8
50	33	8
63	33	8

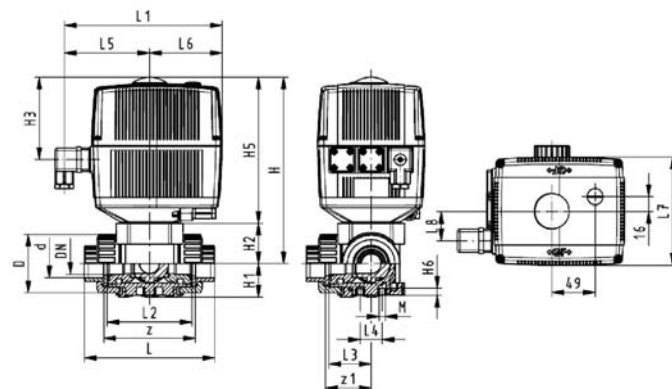

PF 3 39 749



SYGEF® standard
3-Way ball valve type 177
Horizontal/L-port 100-230V
With manual emergency override
With socket fusion spigots

Model:

- Assignment of actuators EA21 (DN10/15-50), EA31 (DN65-100 if available)
- Voltage 100-230 V, 50-60 Hz
- Control range 90°<
- Control time 5 s/90°<
- For easy installation and removal
- Integrated stainless steel mounting inserts

d [mm]	DN [mm]	PN	kv-value ($\Delta p=1$ bar) [l/min]	FPM Code	kg
16	10	10	50	199 177 012	2.178
20	15	10	75	199 177 013	2.178
25	20	10	150	199 177 014	2.408
32	25	10	280	199 177 015	2.618
40	32	10	480	199 177 016	3.053
50	40	10	620	199 177 017	3.744
63	50	10	1230	199 177 018	5.468

d [mm]	D [mm]	H [mm]	H1 [mm]	H2 [mm]	H3 [mm]	H5 [mm]	H6 [mm]	L [mm]	L1 [mm]	L2 [mm]	L3 [mm]	L4 [mm]	L5 [mm]	L6 [mm]	L7 [mm]
16	46	197	29	31	93	166	8	119	182	70	36	25	99	83	122
20	46	197	29	31	93	166	8	133	182	70	36	25	99	83	122
25	56	205	33	39	93	166	8	155	182	86	43	25	99	83	122
32	67	210	38	44	93	166	8	170	182	96	48	25	99	83	122
40	82	216	44	50	93	166	9	201	182	114	58	45	99	83	122
50	98	229	50	63	93	166	9	236	182	137	69	45	99	83	122
63	121	242	61	76	93	166	9	286	182	179	90	45	99	83	122

d [mm]	L8 [mm]	M
16	33	6
20	33	6
25	33	6
32	33	6
40	33	8
50	33	8
63	33	8

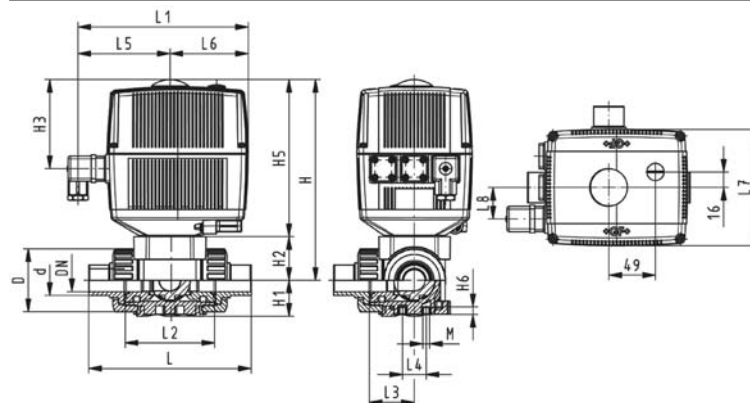

PF 3 39 749



SYGEF® standard
3-Way ball valve type 177
Horizontal/L-port 24V
With manual emergency override
With butt fusion spigots IR metric

Model:

- Assignment of actuators EA21 (DN10/15-50), EA31 (DN65-100 if available)
- Voltage 24 V AC/DC
- Control range 90°<
- Control time 5 s/90°<
- For easy installation and removal
- Integrated stainless steel mounting inserts

d [mm]	DN [mm]	PN	kv-value ($\Delta p=1$ bar) [l/min]	FPM Code	kg
16	10	10	50	199 177 172	2.178
20	15	10	75	199 177 173	2.178
25	20	10	150	199 177 174	2.408
32	25	10	280	199 177 175	2.297
40	32	10	480	199 177 176	3.053
50	40	10	620	199 177 177	3.744
63	50	10	1230	199 177 178	5.468

d [mm]	D [mm]	H [mm]	H1 [mm]	H2 [mm]	H3 [mm]	H5 [mm]	H6 [mm]	L [mm]	L1 [mm]	L2 [mm]	L3 [mm]	L4 [mm]	L5 [mm]	L6 [mm]	L7 [mm]
16	46	197	29	31	93	166	8	119	182	70	36	25	99	83	122
20	46	197	29	31	93	166	8	133	182	70	36	25	99	83	122
25	56	205	33	39	93	166	8	155	182	86	43	25	99	83	122
32	67	210	38	44	93	166	8	170	182	96	48	25	99	83	122
40	82	216	44	50	93	166	9	201	182	114	58	45	99	83	122
50	98	229	50	63	93	166	9	236	182	137	69	45	99	83	122
63	121	242	61	76	93	166	9	286	182	179	90	45	99	83	122

d [mm]	L8 [mm]	M
16	33	6
20	33	6
25	33	6
32	33	6
40	33	8
50	33	8
63	33	8

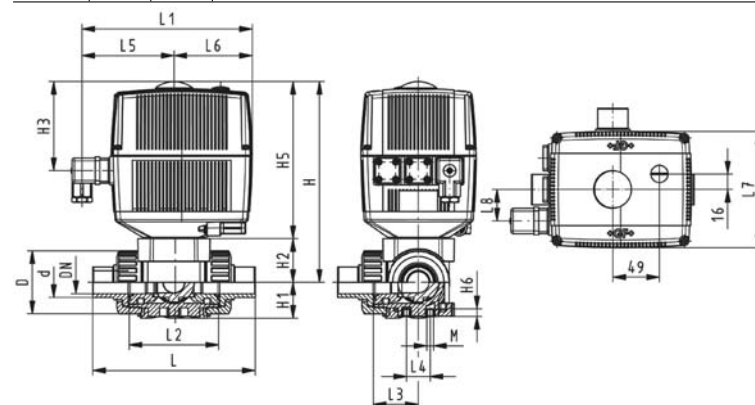

PF 3 39 749



SYGEF® standard
3-Way ball valve type 177
Horizontal/L-port 24V
With manual emergency override
With fusion sockets

Model:

- Assignment of actuators EA21 (DN10/15-50), EA31 (DN65-100 if available)
- Voltage 24 V AC/DC
- Control range 90°<
- Control time 5 s/90°<
- For easy installation and removal
- Integrated stainless steel mounting inserts

d [mm]	DN [mm]	PN	kv-value ($\Delta p=1$ bar) [l/min]	FPM Code	kg
16	10	10	50	199 177 212	2.178
20	15	10	75	199 177 213	2.178
25	20	10	150	199 177 214	2.408
32	25	10	280	199 177 215	2.618
40	32	10	480	199 177 216	3.053
50	40	10	620	199 177 217	3.744
63	50	10	1230	199 177 218	3.818

d [mm]	D [mm]	H [mm]	H1 [mm]	H2 [mm]	H3 [mm]	H5 [mm]	H6 [mm]	L [mm]	L1 [mm]	L2 [mm]	L3 [mm]	L4 [mm]	L5 [mm]	L6 [mm]	L7 [mm]
16	46	197	29	31	93	166	8	119	182	70	36	25	99	83	122
20	46	197	29	31	93	166	8	133	182	70	36	25	99	83	122
25	56	205	33	39	93	166	8	155	182	86	43	25	99	83	122
32	67	210	38	44	93	166	8	170	182	96	48	25	99	83	122
40	82	216	44	50	93	166	9	201	182	114	58	45	99	83	122
50	98	229	50	63	93	166	9	236	182	137	69	45	99	83	122
63	121	242	61	76	93	166	9	286	182	179	90	45	99	83	122

d [mm]	L8 [mm]	M
16	33	6
20	33	6
25	33	6
32	33	6
40	33	8
50	33	8
63	33	8

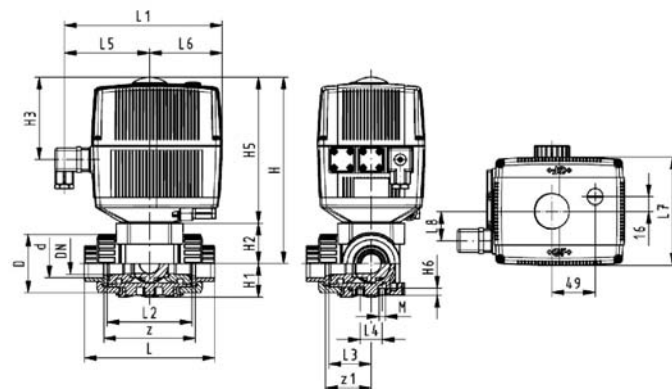

PF 3 39 749



SYGEF® standard
3-Way ball valve type 177
Horizontal/L-port 24V
With manual emergency override
With socket fusion spigots

Model:

- Assignment of actuators EA21 (DN10/15-50), EA31 (DN65-100 if available)
- Voltage 24 V AC/DC
- Control range 90°<
- Control time 5 s/90°<
- For easy installation and removal
- Integrated stainless steel mounting inserts

d [mm]	DN [mm]	PN	kv-value ($\Delta p=1$ bar) [l/min]	FPM Code	kg
16	10	10	50	199 177 132	2.178
20	15	10	75	199 177 133	2.178
25	20	10	150	199 177 134	2.408
32	25	10	280	199 177 135	2.618
40	32	10	480	199 177 136	3.053
50	40	10	620	199 177 137	3.744
63	50	10	1230	199 177 138	5.468

d [mm]	D [mm]	H [mm]	H1 [mm]	H2 [mm]	H3 [mm]	H5 [mm]	H6 [mm]	L [mm]	L1 [mm]	L2 [mm]	L3 [mm]	L4 [mm]	L5 [mm]	L6 [mm]	L7 [mm]
16	46	197	29	31	93	166	8	119	182	70	36	25	99	83	122
20	46	197	29	31	93	166	8	133	182	70	36	25	99	83	122
25	56	205	33	39	93	166	8	155	182	86	43	25	99	83	122
32	67	210	38	44	93	166	8	170	182	96	48	25	99	83	122
40	82	216	44	50	93	166	9	201	182	114	58	45	99	83	122
50	98	229	50	63	93	166	9	236	182	137	69	45	99	83	122
63	121	242	61	76	93	166	9	286	182	179	90	45	99	83	122

d [mm]	L8 [mm]	M
16	33	6
20	33	6
25	33	6
32	33	6
40	33	8
50	33	8
63	33	8

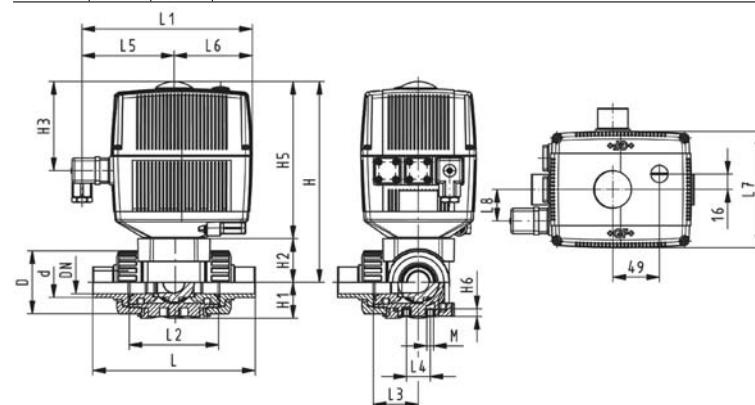

PF 3 39 749



SYGEF® standard
3-Way ball valve type 177
Horizontal/T-port 100-230V
With manual emergency override
With butt fusion spigots IR metric

E

Model:

- Assignment of actuators EA21 (DN10/15-50), EA31 (DN65-100 if available)
- Voltage 100-230 V, 50-60 Hz
- Control range 90°<
- Control time 5 s/90°<
- For easy installation and removal
- Integrated stainless steel mounting inserts

d [mm]	DN [mm]	PN	kv-value ($\Delta p=1$ bar) [l/min]	FPM Code	kg
16	10	10	140	199 177 072	2.178
20	15	10	200	199 177 073	2.178
25	20	10	470	199 177 074	2.408
32	25	10	793	199 177 075	2.618
40	32	10	1290	199 177 076	3.053
50	40	10	1910	199 177 077	3.105
63	50	10	3100	199 177 078	5.468

d [mm]	D [mm]	H [mm]	H1 [mm]	H2 [mm]	H3 [mm]	H5 [mm]	H6 [mm]	L [mm]	L1 [mm]	L2 [mm]	L3 [mm]	L4 [mm]	L5 [mm]	L6 [mm]	L7 [mm]
16	46	197	29	31	93	166	8	119	182	70	36	25	99	83	122
20	46	197	29	31	93	166	8	133	182	70	36	25	99	83	122
25	56	205	33	39	93	166	8	155	182	86	43	25	99	83	122
32	67	210	38	44	93	166	8	170	182	96	48	25	99	83	122
40	82	216	44	50	93	166	9	201	182	114	58	45	99	83	122
50	98	229	50	63	93	166	9	236	182	137	69	45	99	83	122
63	121	242	61	76	93	166	9	286	182	179	90	45	99	83	122

d [mm]	L8 [mm]	M
16	33	6
20	33	6
25	33	6
32	33	6
40	33	8
50	33	8
63	33	8

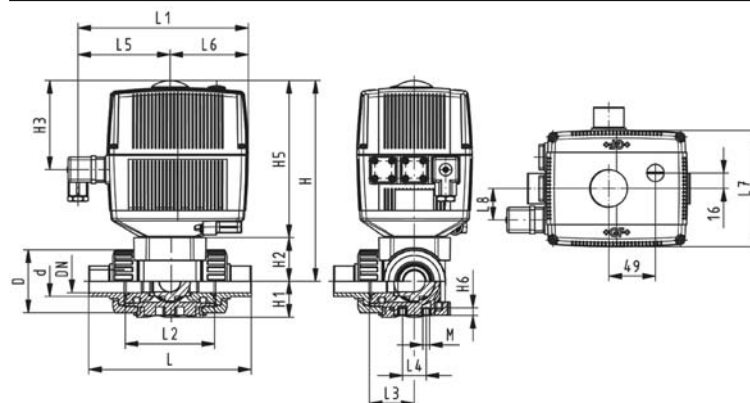

PF 3 39 749



SYGEF® standard
3-Way ball valve type 177
Horizontal/T-port 100-230V
With manual emergency override
With fusion sockets

E

Model:

- Assignment of actuators EA21 (DN10/15-50), EA31 (DN65-100 if available)
- Voltage 100-230 V, 50-60 Hz
- Control range 90°<
- Control time 5 s/90°<
- For easy installation and removal
- Integrated stainless steel mounting inserts

d [mm]	DN [mm]	PN	kv-value ($\Delta p=1$ bar) [l/min]	FPM Code	kg
16	10	10	140	199 177 112	2.178
20	15	10	200	199 177 113	2.178
25	20	10	470	199 177 114	2.408
32	25	10	793	199 177 115	2.618
40	32	10	1290	199 177 116	3.053
50	40	10	1910	199 177 117	3.744
63	50	10	3100	199 177 118	3.818

d [mm]	D [mm]	H [mm]	H1 [mm]	H2 [mm]	H3 [mm]	H5 [mm]	H6 [mm]	L [mm]	L1 [mm]	L2 [mm]	L3 [mm]	L4 [mm]	L5 [mm]	L6 [mm]	L7 [mm]
16	46	197	29	31	93	166	8	119	182	70	36	25	99	83	122
20	46	197	29	31	93	166	8	133	182	70	36	25	99	83	122
25	56	205	33	39	93	166	8	155	182	86	43	25	99	83	122
32	67	210	38	44	93	166	8	170	182	96	48	25	99	83	122
40	82	216	44	50	93	166	9	201	182	114	58	45	99	83	122
50	98	229	50	63	93	166	9	236	182	137	69	45	99	83	122
63	121	242	61	76	93	166	9	286	182	179	90	45	99	83	122

d [mm]	L8 [mm]	M
16	33	6
20	33	6
25	33	6
32	33	6
40	33	8
50	33	8
63	33	8

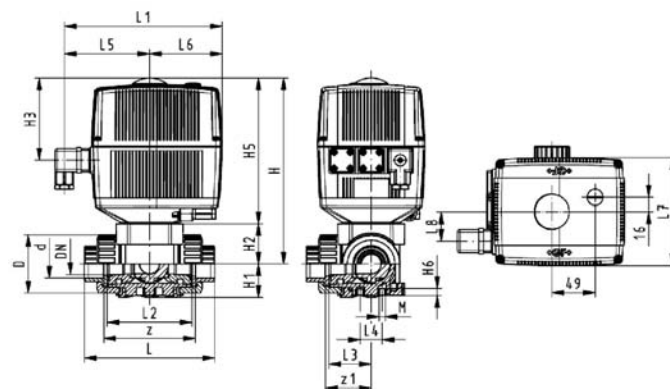

PF 3 39 749



SYGEF® standard
3-Way ball valve type 177
Horizontal/T-port 100-230V
With manual emergency override
With socket fusion spigots

E

Model:

- Assignment of actuators EA21 (DN10/15-50), EA31 (DN65-100 if available)
- Voltage 100-230 V, 50-60 Hz
- Control range 90°<
- Control time 5 s/90°<
- For easy installation and removal
- Integrated stainless steel mounting inserts

d [mm]	DN [mm]	PN	kv-value ($\Delta p=1$ bar) [l/min]	FPM Code	kg
16	10	10	140	199 177 032	2.178
20	15	10	200	199 177 033	2.178
25	20	10	470	199 177 034	2.408
32	25	10	793	199 177 035	2.618
40	32	10	1290	199 177 036	3.053
50	40	10	1910	199 177 037	3.744
63	50	10	3100	199 177 038	5.468

d [mm]	D [mm]	H [mm]	H1 [mm]	H2 [mm]	H3 [mm]	H5 [mm]	H6 [mm]	L [mm]	L1 [mm]	L2 [mm]	L3 [mm]	L4 [mm]	L5 [mm]	L6 [mm]	L7 [mm]
16	46	197	29	31	93	166	8	119	182	70	36	25	99	83	122
20	46	197	29	31	93	166	8	133	182	70	36	25	99	83	122
25	56	205	33	39	93	166	8	155	182	86	43	25	99	83	122
32	67	210	38	44	93	166	8	170	182	96	48	25	99	83	122
40	82	216	44	50	93	166	9	201	182	114	58	45	99	83	122
50	98	229	50	63	93	166	9	236	182	137	69	45	99	83	122
63	121	242	61	76	93	166	9	286	182	179	90	45	99	83	122

d [mm]	L8 [mm]	M
16	33	6
20	33	6
25	33	6
32	33	6
40	33	8
50	33	8
63	33	8

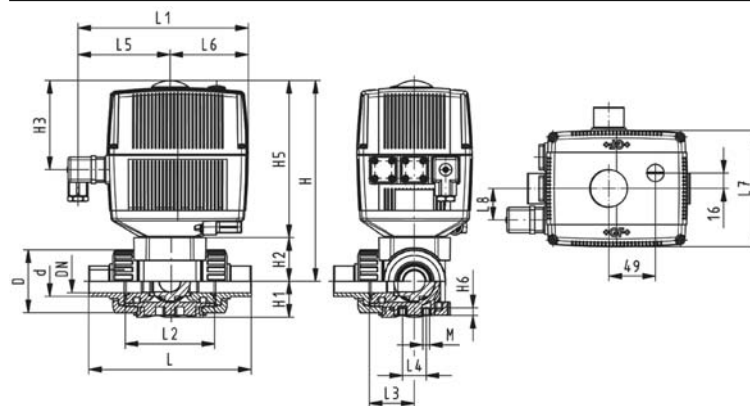

PF 3 39 749



SYGEF® standard
3-Way ball valve type 177
Horizontal/T-port 24V
With manual emergency override
With butt fusion spigots IR metric

Model:

- Assignment of actuators EA21 (DN10/15-50), EA31 (DN65-100 if available)
- Voltage 24 V AC/DC
- Control range 90°<
- Control time 5 s/90°<
- For easy installation and removal
- Integrated stainless steel mounting inserts

d [mm]	DN [mm]	PN	kv-value ($\Delta p=1$ bar) [l/min]	FPM Code	kg
16	10	10	140	199 177 192	2.178
20	15	10	200	199 177 193	2.178
25	20	10	470	199 177 194	2.408
32	25	10	793	199 177 195	2.618
40	32	10	1290	199 177 196	3.053
50	40	10	1910	199 177 197	3.744
63	50	10	3100	199 177 198	5.468

d [mm]	D [mm]	H [mm]	H1 [mm]	H2 [mm]	H3 [mm]	H5 [mm]	H6 [mm]	L [mm]	L1 [mm]	L2 [mm]	L3 [mm]	L4 [mm]	L5 [mm]	L6 [mm]	L7 [mm]
16	46	197	29	31	93	166	8	119	182	70	36	25	99	83	122
20	46	197	29	31	93	166	8	133	182	70	36	25	99	83	122
25	56	205	33	39	93	166	8	155	182	86	43	25	99	83	122
32	67	210	38	44	93	166	8	170	182	96	48	25	99	83	122
40	82	216	44	50	93	166	9	201	182	114	58	45	99	83	122
50	98	229	50	63	93	166	9	236	182	137	69	45	99	83	122
63	121	242	61	76	93	166	9	286	182	179	90	45	99	83	122

d [mm]	L8 [mm]	M
16	33	6
20	33	6
25	33	6
32	33	6
40	33	8
50	33	8
63	33	8

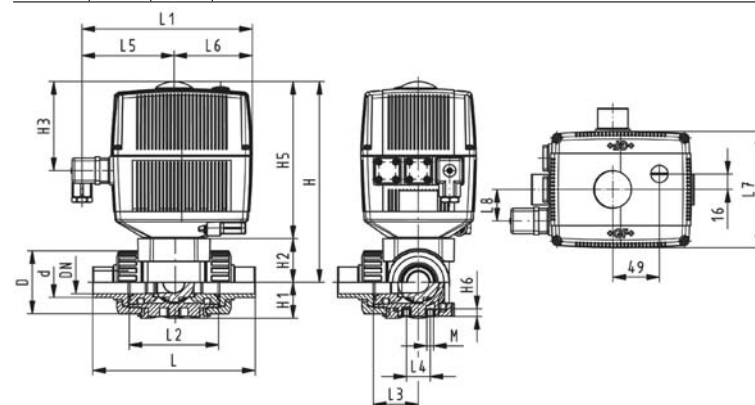

PF 3 39 749



SYGEF® standard
3-Way ball valve type 177
Horizontal/T-port 24V
With manual emergency override
With fusion sockets

Model:

- Assignment of actuators EA21 (DN10/15-50), EA31 (DN65-100 if available)
- Voltage 24 V AC/DC
- Control range 90°<
- Control time 5 s/90°<
- For easy installation and removal
- Integrated stainless steel mounting inserts

d [mm]	DN [mm]	PN	kv-value ($\Delta p=1$ bar) [l/min]	FPM Code	kg
16	10	10	140	199 177 232	2.178
20	15	10	200	199 177 233	2.178
25	20	10	470	199 177 234	2.408
32	25	10	793	199 177 235	2.618
40	32	10	1290	199 177 236	3.053
50	40	10	1910	199 177 237	3.744
63	50	10	3100	199 177 238	5.468

d [mm]	D [mm]	H [mm]	H1 [mm]	H2 [mm]	H3 [mm]	H5 [mm]	H6 [mm]	L [mm]	L1 [mm]	L2 [mm]	L3 [mm]	L4 [mm]	L5 [mm]	L6 [mm]	L7 [mm]
16	46	197	29	31	93	166	8	119	182	70	36	25	99	83	122
20	46	197	29	31	93	166	8	133	182	70	36	25	99	83	122
25	56	205	33	39	93	166	8	155	182	86	43	25	99	83	122
32	67	210	38	44	93	166	8	170	182	96	48	25	99	83	122
40	82	216	44	50	93	166	9	201	182	114	58	45	99	83	122
50	98	229	50	63	93	166	9	236	182	137	69	45	99	83	122
63	121	242	61	76	93	166	9	286	182	179	90	45	99	83	122

d [mm]	L8 [mm]	M
16	33	6
20	33	6
25	33	6
32	33	6
40	33	8
50	33	8
63	33	8

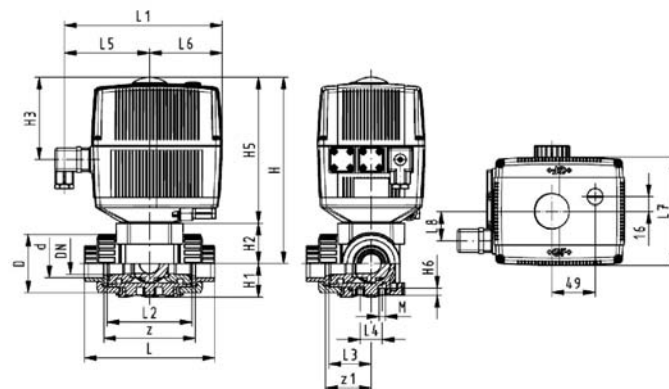

PF 3 39 749



SYGEF® standard
3-Way ball valve type 177
Horizontal/T-port 24V
With manual emergency override
With socket fusion spigots

Model:

- Assignment of actuators EA21 (DN10/15-50), EA31 (DN65-100 if available)
- Voltage 24 V AC/DC
- Control range 90°<
- Control time 5 s/90°<
- For easy installation and removal
- Integrated stainless steel mounting inserts

d [mm]	DN [mm]	PN	kv-value ($\Delta p=1$ bar) [l/min]	FPM Code	kg
16	10	10	140	199 177 152	2.178
20	15	10	200	199 177 153	2.178
25	20	10	470	199 177 154	2.408
32	25	10	793	199 177 155	2.618
40	32	10	1290	199 177 156	3.053
50	40	10	1910	199 177 157	3.744
63	50	10	3100	199 177 158	5.468

d [mm]	D [mm]	H [mm]	H1 [mm]	H2 [mm]	H3 [mm]	H5 [mm]	H6 [mm]	L [mm]	L1 [mm]	L2 [mm]	L3 [mm]	L4 [mm]	L5 [mm]	L6 [mm]	L7 [mm]
16	46	197	29	31	93	166	8	119	182	70	36	25	99	83	122
20	46	197	29	31	93	166	8	133	182	70	36	25	99	83	122
25	56	205	33	39	93	166	8	155	182	86	43	25	99	83	122
32	67	210	38	44	93	166	8	170	182	96	48	25	99	83	122
40	82	216	44	50	93	166	9	201	182	114	58	45	99	83	122
50	98	229	50	63	93	166	9	236	182	137	69	45	99	83	122
63	121	242	61	76	93	166	9	286	182	179	90	45	99	83	122

d [mm]	L8 [mm]	M
16	33	6
20	33	6
25	33	6
32	33	6
40	33	8
50	33	8
63	33	8

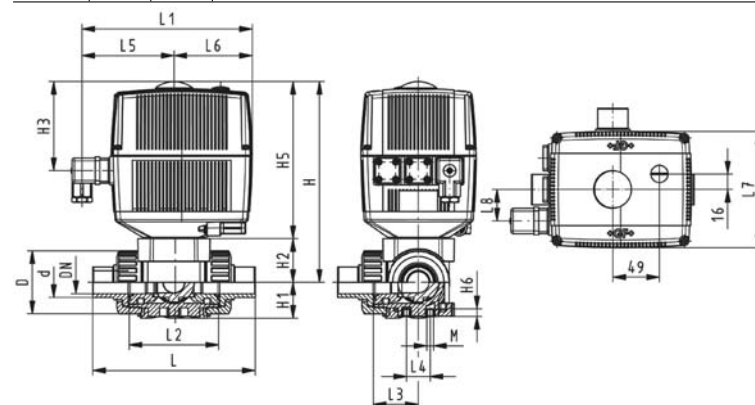

PF 3 39 749

Ball valves pneumatic

SYGEF® standard Ball valve type 232 Function FC (Fail safe to close) With manual override With butt fusion spigots metric

E



DN10/15 - 50

Model:

- Built on with pneumatic actuator PA11/21
- For easy installation and removal
- Integrated stainless steel mounting inserts
- Control time $90^\circ \leq 1-2$ s

Option:

- Individual configuration of the valve (see form)

d [mm]	DN [mm]	PN	kv-value ($\Delta p=1$ bar) [l/min]	FPM Code
20	15	10	185	199 232 713
25	20	10	350	199 232 714
32	25	10	700	199 232 715
40	32	10	1000	199 232 716
50	40	10	1600	199 232 717
63	50	10	3100	199 232 718

d [mm]	D [mm]	H [mm]	H1 [mm]	H2 [mm]	H3 [mm]	H4 [mm]	H5 [mm]	L [mm]	L1 [mm]	L2 [mm]	L4 [mm]	L5 [mm]	L6 [mm]	L7 [mm]
20	50	230	27	62	168	40	97	130	194	56	25	261	76	48
25	58	239	30	71	168	40	97	130	194	65	25	261	76	48
32	68	239	36	71	168	40	97	130	194	71	25	261	76	48
40	84	271	44	84	187	51	115	130	224	85	45	305	95	59
50	97	271	51	84	187	51	115	130	224	89	45	305	95	59
63	124	293	64	106	187	51	115	130	224	101	45	305	95	59

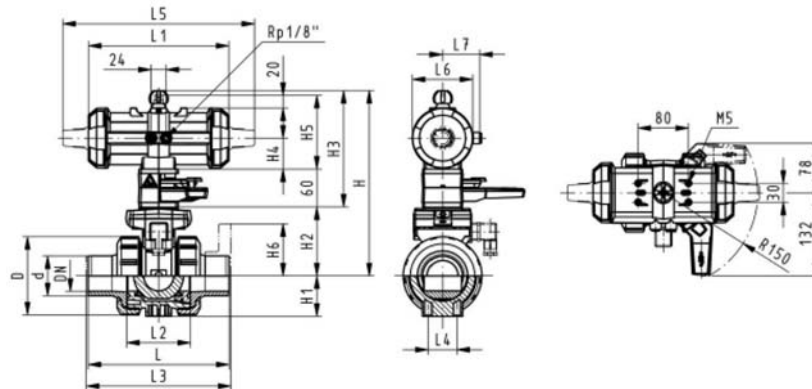

PF 3 39 696



DN10/15 - 50

SYGEF® standard
Ball valve type 232
Function FC (Fail safe to close)
With manual override
With fusion Sockets metric

E

Model:

- Built on with pneumatic actuator PA11/21
- For easy installation and removal
- Integrated stainless steel mounting inserts
- Control time 90°<) 1-2 s

Option:

- Individual configuration of the valve (see form)

d [mm]	DN [mm]	PN	kv-value ($\Delta p=1$ bar) [l/min]	FPM Code	kg
16	10	10	70	199 232 012	1.500
20	15	10	185	199 232 013	1.500
25	20	10	350	199 232 014	1.600
32	25	10	700	199 232 015	1.700
40	32	10	1000	199 232 016	2.800
50	40	10	1600	199 232 017	3.100
63	50	10	3100	199 232 018	4.000

d [mm]	D [mm]	H [mm]	H1 [mm]	H2 [mm]	H3 [mm]	H4 [mm]	H5 [mm]	L [mm]	L1 [mm]	L2 [mm]	L4 [mm]	L5 [mm]	L6 [mm]	L7 [mm]	z [mm]
16	50	230	27	62	168	40	97	92	194	56	25	261	76	48	64
20	50	230	27	62	168	40	97	95	194	56	25	261	76	48	64
25	58	239	30	71	168	40	97	110	194	65	25	261	76	48	72
32	68	239	36	71	168	40	97	123	194	71	25	261	76	48	79
40	84	271	44	84	187	51	115	146	224	85	45	305	95	59	94
50	97	271	51	84	187	51	115	157	224	89	45	305	95	59	95
63	124	293	64	106	187	51	115	183	224	101	45	305	95	59	107

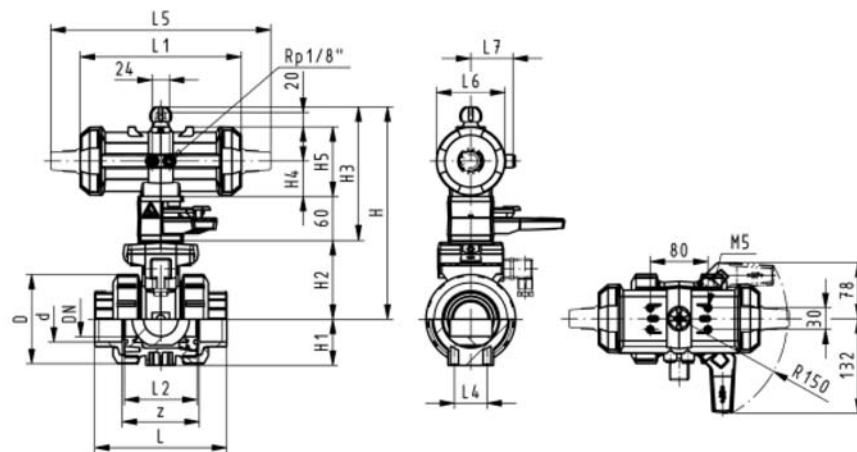

PF 3 39 696



DN10/15 - 50

SYGEF® standard
Ball valve type 232
Function FC (Fail safe to close)
With manual override
With fusion spigots metric

E

Model:

- Built on with pneumatic actuator PA11/21
- For easy installation and removal
- Integrated stainless steel mounting inserts
- Control time 90°<) 1-2 s

Option:

- Individual configuration of the valve (see form)

d [mm]	DN [mm]	PN	kv-value ($\Delta p=1$ bar) [l/min]	FPM Code	kg
16	10	10	70	199 232 032	1.500
20	15	10	185	199 232 033	1.500
25	20	10	350	199 232 034	1.600
32	25	10	700	199 232 035	1.700
40	32	10	1000	199 232 036	2.800
50	40	10	1600	199 232 037	3.100
63	50	10	3100	199 232 038	4.000

d [mm]	D [mm]	H [mm]	H1 [mm]	H2 [mm]	H3 [mm]	H4 [mm]	H5 [mm]	L [mm]	L1 [mm]	L2 [mm]	L3 [mm]	L4 [mm]	L5 [mm]	L6 [mm]	L7 [mm]
16	50	230	27	62	168	40	97	92	194	56	130	25	261	76	48
20	50	230	27	62	168	40	97	95	194	56	130	25	261	76	48
25	58	239	30	71	168	40	97	110	194	65	150	25	261	76	48
32	68	239	36	71	168	40	97	123	194	71	160	25	261	76	48
40	84	271	44	84	187	51	115	146	224	85	180	45	305	95	59
50	97	271	51	84	187	51	115	157	224	89	200	45	305	95	59
63	124	293	64	106	187	51	115	183	224	101	230	45	305	95	59

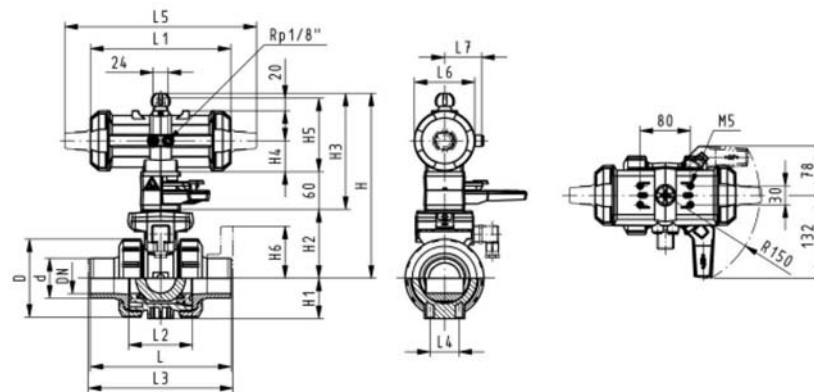

PF 3 39 696



DN10/15 - 50

SYGEF® standard
Ball valve type 232
Function FC (Fail safe to close)
With manual override
With fixed flanges PVDF serrated metric

E

Model:

- Built on with pneumatic actuator PA11/21
- For easy installation and removal
- Integrated stainless steel mounting inserts
- Control time 90°<) 1-2 s
- Connecting dimensions: ISO 7005 / EN 1092 / DIN 2501 PN10 / BS4504

Option:

- Individual configuration of the valve (see form)

d [mm]	DN [mm]	Inch	PN	kv-value ($\Delta p=1$ bar) [l/min]	FPM Code	kg
20	15	½	10	185	199 232 003	1.700
25	20	¾	10	350	199 232 004	1.900
32	25	1	10	700	199 232 005	2.100
40	32	1 ¼	10	1000	199 232 006	3.400
50	40	1 ½	10	1600	199 232 007	3.900
63	50	2	10	3100	199 232 008	5.000

d [mm]	D [mm]	H [mm]	H1 [mm]	H2 [mm]	H3 [mm]	H4 [mm]	H5 [mm]	H6 [mm]	L [mm]	L1 [mm]	L2 [mm]	L3 [mm]	L4 [mm]	L5 [mm]	L6 [mm]
20	50	230	27	62	168	40	97	48	124	194	56	130	25	261	76
25	58	239	30	71	168	40	97	53	144	194	65	150	25	261	76
32	68	239	36	71	168	40	97	58	154	194	71	160	25	261	76
40	84	271	44	84	187	51	115	70	174	224	85	180	45	305	95
50	97	271	51	84	187	51	115	75	194	224	89	200	45	305	95
63	124	293	64	106	187	51	115	83	224	224	101	230	45	305	95

d [mm]	L7 [mm]
20	48
25	48
32	48
40	59
50	59
63	59

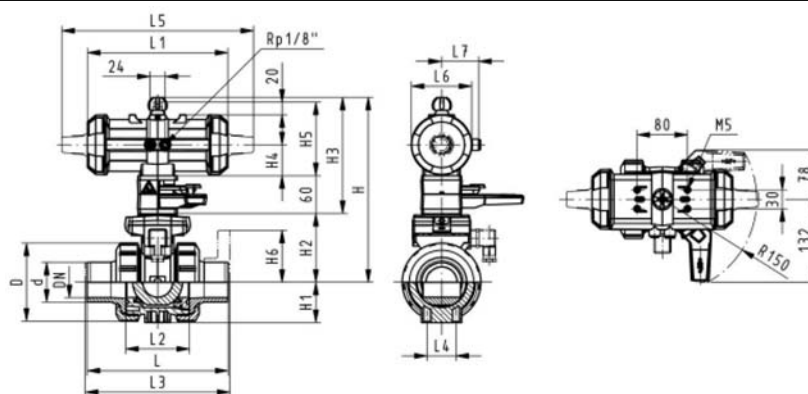

PF 3 39 696



DN10/15 - 50

SYGEF® standard
Ball valve type 232
Function FO (Fail safe to open)
With manual override
With butt fusion spigots metric

E

Model:

- Built on with pneumatic actuator PA11/21
- For easy installation and removal
- Integrated stainless steel mounting inserts
- Control time 90°<) 1-2 s

Option:

- Individual configuration of the valve (see form)

d [mm]	DN [mm]	PN	kv-value ($\Delta p=1$ bar) [l/min]	FPM Code
20	15	10	185	199 232 753
25	20	10	350	199 232 754
32	25	10	700	199 232 755
40	32	10	1000	199 232 756
50	40	10	1600	199 232 757
63	50	10	3100	199 232 758

d [mm]	D [mm]	H [mm]	H1 [mm]	H2 [mm]	H3 [mm]	H4 [mm]	H5 [mm]	L [mm]	L1 [mm]	L2 [mm]	L4 [mm]	L5 [mm]	L6 [mm]	L7 [mm]
20	50	230	27	62	168	40	97	130	194	56	25	261	76	48
25	58	239	30	71	168	40	97	130	194	65	25	261	76	48
32	68	239	36	71	168	40	97	130	194	71	25	261	76	48
40	84	271	44	84	187	51	115	130	224	85	45	305	95	59
50	97	271	51	84	187	51	115	130	224	89	45	305	95	59
63	124	293	64	106	187	51	115	130	224	101	45	305	95	59

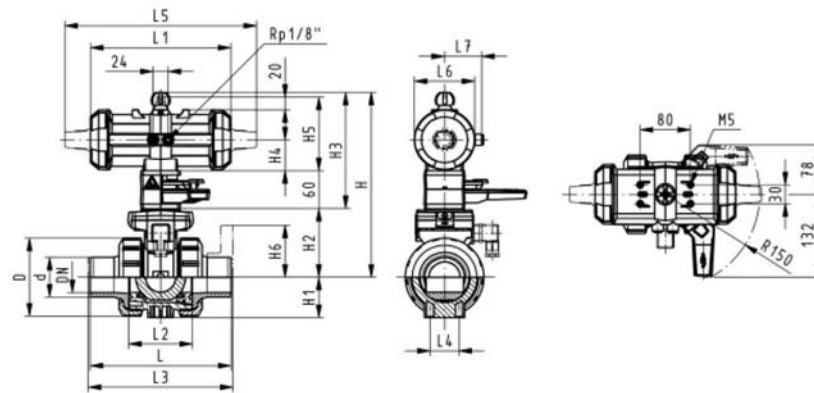

PF 3 39 696



DN10/15 - 50

SYGEF® standard
Ball valve type 232
Function FO (Fail safe to open)
With manual override
With fusion sockets metric

E

Model:

- Built on with pneumatic actuator PA11/21
- For easy installation and removal
- Integrated stainless steel mounting inserts
- Control time 90°<) 1-2 s

Option:

- Individual configuration of the valve (see form)

d [mm]	DN [mm]	PN	kv-value ($\Delta p=1$ bar) [l/min]	FPM Code	kg
16	10	10	70	199 232 052	1.500
20	15	10	185	199 232 053	1.500
25	20	10	350	199 232 054	1.600
32	25	10	700	199 232 055	1.700
40	32	10	1000	199 232 056	2.800
50	40	10	1600	199 232 057	3.100
63	50	10	3100	199 232 058	4.000

d [mm]	D [mm]	H [mm]	H1 [mm]	H2 [mm]	H3 [mm]	H4 [mm]	H5 [mm]	L [mm]	L1 [mm]	L2 [mm]	L4 [mm]	L5 [mm]	L6 [mm]	L7 [mm]	z [mm]
16	50	230	27	62	168	40	97	92	194	56	25	261	76	48	64
20	50	230	27	62	168	40	97	95	194	56	25	261	76	48	64
25	58	239	30	71	168	40	97	110	194	65	25	261	76	48	72
32	68	239	36	71	168	40	97	123	194	71	25	261	76	48	79
40	84	271	44	84	187	51	115	146	224	85	45	305	95	59	94
50	97	271	51	84	187	51	115	157	224	89	45	305	95	59	95
63	124	293	64	106	187	51	115	183	224	101	45	305	95	59	107

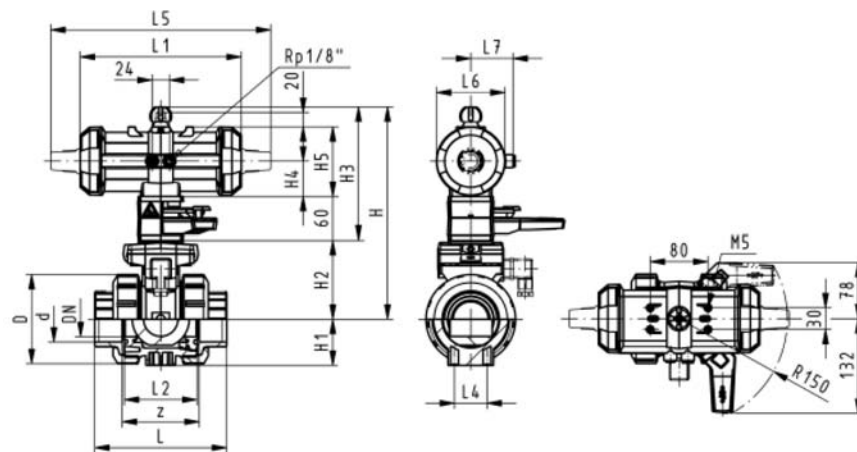

PF 3 39 696



DN10/15 - 50

SYGEF® standard
Ball valve type 232
Function FO (Fail safe to open)
With manual override
With fusion spigots metric

E

Model:

- Built on with pneumatic actuator PA11/21
- For easy installation and removal
- Integrated stainless steel mounting inserts
- Control time 90°<) 1-2 s

Option:

- Individual configuration of the valve (see form)

d [mm]	DN [mm]	PN	kv-value ($\Delta p=1$ bar) [l/min]	FPM Code	kg
16	10	10	70	199 232 072	1.500
20	15	10	185	199 232 073	1.500
25	20	10	350	199 232 074	1.600
32	25	10	700	199 232 075	1.700
40	32	10	1000	199 232 076	2.800
50	40	10	1600	199 232 077	3.100
63	50	10	3100	199 232 078	4.000

d [mm]	D [mm]	H [mm]	H1 [mm]	H2 [mm]	H3 [mm]	H4 [mm]	H5 [mm]	L [mm]	L1 [mm]	L2 [mm]	L3 [mm]	L4 [mm]	L5 [mm]	L6 [mm]	L7 [mm]
16	50	230	27	62	168	40	97	92	194	56	130	25	261	76	48
20	50	230	27	62	168	40	97	95	194	56	130	25	261	76	48
25	58	239	30	71	168	40	97	110	194	65	150	25	261	76	48
32	68	239	36	71	168	40	97	123	194	71	160	25	261	76	48
40	84	271	44	84	187	51	115	146	224	85	180	45	305	95	59
50	97	271	51	84	187	51	115	157	224	89	200	45	305	95	59
63	124	293	64	106	187	51	115	183	224	101	230	45	305	95	59

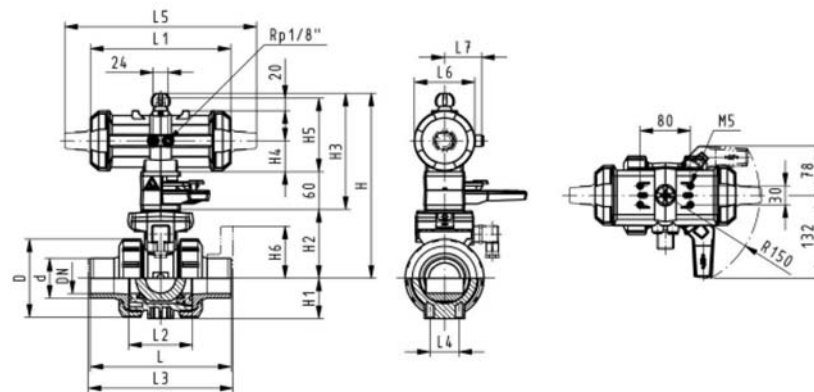

PF 3 39 696



SYGEF® standard
Ball valve type 232
Function FO (Fail safe to open)
With manual override
With fixed flanges PVDF serrated metric

E

Model:

- Built on with pneumatic actuator PA11/21
- For easy installation and removal
- Integrated stainless steel mounting inserts
- Control time 90°<) 1-2 s
- Overall length EN 558-1
- Connecting dimensions: ISO 7005 / EN 1092 / DIN 2501 PN10 / BS4504

Option:

- Individual configuration of the valve (see form)

d [mm]	DN [mm]	Inch	PN	kv-value ($\Delta p=1$ bar) [l/min]	FPM Code	kg
20	15	½	10	185	199 232 023	1.700
25	20	¾	10	350	199 232 024	1.900
32	25	1	10	700	199 232 025	2.100
40	32	1 ¼	10	1000	199 232 026	3.400
50	40	1 ½	10	1600	199 232 027	3.900
63	50	2	10	3100	199 232 028	5.000

d [mm]	D [mm]	H [mm]	H1 [mm]	H2 [mm]	H3 [mm]	H4 [mm]	H5 [mm]	H6 [mm]	L [mm]	L1 [mm]	L2 [mm]	L3 [mm]	L4 [mm]	L5 [mm]	L6 [mm]
20	50	230	27	62	168	40	97	48	124	194	56	130	25	261	76
25	58	239	30	71	168	40	97	53	144	194	65	150	25	261	76
32	68	239	36	71	168	40	97	58	154	194	71	160	25	261	76
40	84	271	44	84	187	51	115	70	174	224	85	180	45	305	95
50	97	271	51	84	187	51	115	75	194	224	89	200	45	305	95
63	124	293	64	106	187	51	115	83	224	224	101	230	45	305	95

d [mm]	L7 [mm]
20	48
25	48
32	48
40	59
50	59
63	59

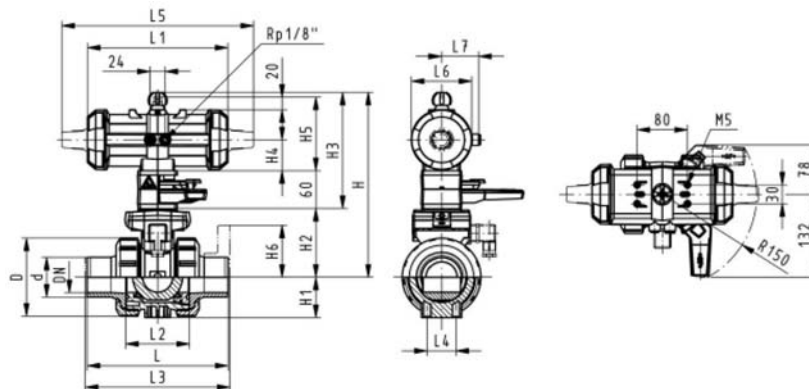

PF 3 39 696



DN10/15 - 50

SYGEF® standard
Ball valve type 232
Function DA (Double acting)
With manual override
With butt fusion spigots metric

E

Model:

- Built on with pneumatic actuator PA11/21
- For easy installation and removal
- Integrated stainless steel mounting inserts
- Control time 90°<) 1-2 s

Option:

- Individual configuration of the valve (see form)

d [mm]	DN [mm]	PN	kv-value ($\Delta p=1$ bar) [l/min]	FPM Code
20	15	10	185	199 232 793
25	20	10	350	199 232 794
32	25	10	700	199 232 795
40	32	10	1000	199 232 796
50	40	10	1600	199 232 797
63	50	10	3100	199 232 798

d [mm]	D [mm]	H [mm]	H1 [mm]	H2 [mm]	H3 [mm]	H4 [mm]	H5 [mm]	L [mm]	L1 [mm]	L2 [mm]	L4 [mm]	L5 [mm]	L6 [mm]	L7 [mm]
20	50	230	27	62	168	40	97	130	194	56	25	261	76	48
25	58	239	30	71	168	40	97	130	194	65	25	261	76	48
32	68	239	36	71	168	40	97	130	194	71	25	261	76	48
40	84	271	44	84	187	51	115	130	224	85	45	305	95	59
50	97	271	51	84	187	51	115	130	224	89	45	305	95	59
63	124	293	64	106	187	51	115	130	224	101	45	305	95	59

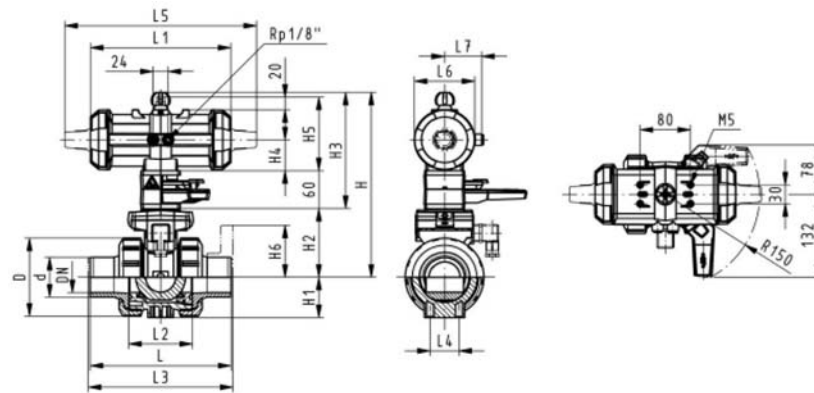

PF 3 39 696



DN10/15 - 50

SYGEF® standard
Ball valve type 232
Function DA (Double acting)
With manual override
With fusion sockets metric

E

Model:

- Built on with pneumatic actuator PA11/21
- For easy installation and removal
- Integrated stainless steel mounting inserts
- Control time 90°<) 1-2 s

Option:

- Individual configuration of the valve (see form)

d [mm]	DN [mm]	PN	kv-value ($\Delta p=1$ bar) [l/min]	FPM Code	kg
16	10	10	70	199 232 092	1.500
20	15	10	185	199 232 093	1.500
25	20	10	350	199 232 094	1.600
32	25	10	700	199 232 095	1.700
40	32	10	1000	199 232 096	2.800
50	40	10	1600	199 232 097	3.100
63	50	10	3100	199 232 098	4.000

d [mm]	D [mm]	H [mm]	H1 [mm]	H2 [mm]	H3 [mm]	H4 [mm]	H5 [mm]	L [mm]	L1 [mm]	L2 [mm]	L4 [mm]	L5 [mm]	L6 [mm]	L7 [mm]	z [mm]
16	50	230	27	62	168	40	97	92	194	56	25	261	76	48	64
20	50	230	27	62	168	40	97	95	194	56	25	261	76	48	64
25	58	239	30	71	168	40	97	110	194	65	25	261	76	48	72
32	68	239	36	71	168	40	97	123	194	71	25	261	76	48	79
40	84	271	44	84	187	51	115	146	224	85	45	305	95	59	94
50	97	271	51	84	187	51	115	157	224	89	45	305	95	59	95
63	124	293	64	106	187	51	115	183	224	101	45	305	95	59	107

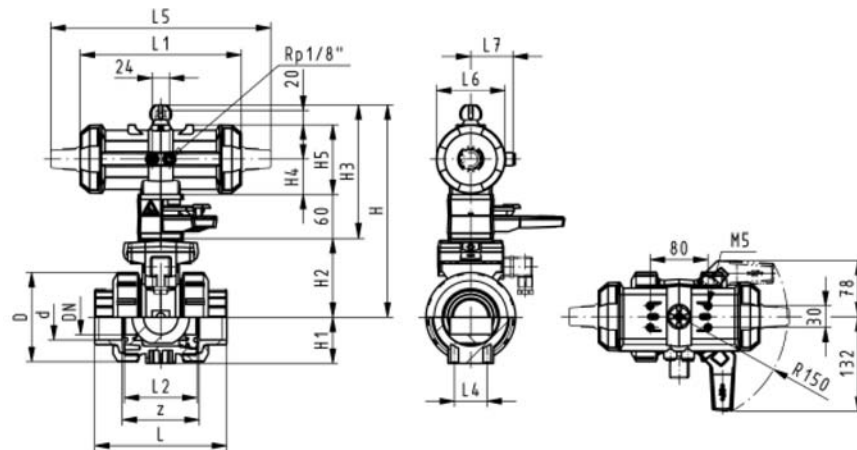

PF 3 39 696



DN10/15 - 50

SYGEF® standard Ball valve type 232 Function DA (Double acting) With manual override With fusion spigots metric

E

Model:

- Built on with pneumatic actuator PA11/21
- For easy installation and removal
- Integrated stainless steel mounting inserts
- Control time 90°<) 1-2 s

Option:

- Individual configuration of the valve (see form)

d [mm]	DN [mm]	PN	kv-value ($\Delta p=1$ bar) [l/min]	FPM Code	kg
16	10	10	70	199 232 112	1.500
20	15	10	185	199 232 113	1.500
25	20	10	350	199 232 114	1.600
32	25	10	700	199 232 115	1.700
40	32	10	1000	199 232 116	2.800
50	40	10	1600	199 232 117	3.100
63	50	10	3100	199 232 118	4.000

d [mm]	D [mm]	H [mm]	H1 [mm]	H2 [mm]	H3 [mm]	H4 [mm]	H5 [mm]	L [mm]	L1 [mm]	L2 [mm]	L3 [mm]	L4 [mm]	L5 [mm]	L6 [mm]	L7 [mm]
16	50	230	27	62	168	40	97	92	194	56	130	25	261	76	48
20	50	230	27	62	168	40	97	95	194	56	130	25	261	76	48
25	58	239	30	71	168	40	97	110	194	65	150	25	261	76	48
32	68	239	36	71	168	40	97	123	194	71	160	25	261	76	48
40	84	271	44	84	187	51	115	146	224	85	180	45	305	95	59
50	97	271	51	84	187	51	115	157	224	89	200	45	305	95	59
63	124	293	64	106	187	51	115	183	224	101	230	45	305	95	59

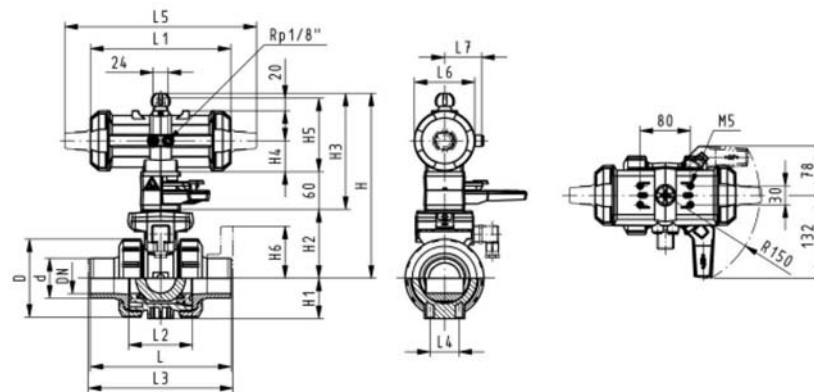

PF 3 39 696



DN10/15 - 50

SYGEF® standard
Ball valve type 232
Function DA (Double acting)
With manual override
With fixed flanges PVDF serrated metric

E

Model:

- Built on with pneumatic actuator PA11/21
- For easy installation and removal
- Integrated stainless steel mounting inserts
- Control time 90°<) 1-2 s
- Overall length EN 558-1
- Connecting dimensions: ISO 7005 / EN 1092 / DIN 2501 PN10 / BS4504

Option:

- Individual configuration of the valve (see form)

d [mm]	DN [mm]	Inch	PN	kv-value ($\Delta p=1$ bar) [l/min]	FPM Code	kg
20	15	½	10	185	199 232 043	1.700
25	20	¾	10	350	199 232 044	1.900
32	25	1	10	700	199 232 045	2.100
40	32	1 ¼	10	1000	199 232 046	3.400
50	40	1 ½	10	1600	199 232 047	3.900
63	50	2	10	3100	199 232 048	5.000

d [mm]	D [mm]	H [mm]	H1 [mm]	H2 [mm]	H3 [mm]	H4 [mm]	H5 [mm]	H6 [mm]	L [mm]	L1 [mm]	L2 [mm]	L3 [mm]	L4 [mm]	L5 [mm]	L6 [mm]
20	50	230	27	62	168	40	97	48	124	194	56	130	25	261	76
25	58	239	30	71	168	40	97	53	144	194	65	150	25	261	76
32	68	239	36	71	168	40	97	58	154	194	71	160	25	261	76
40	84	271	44	84	187	51	115	70	174	224	85	180	45	305	95
50	97	271	51	84	187	51	115	75	194	224	89	200	45	305	95
63	124	293	64	106	187	51	115	83	224	224	101	230	45	305	95

d [mm]	L7 [mm]
20	48
25	48
32	48
40	59
50	59
63	59

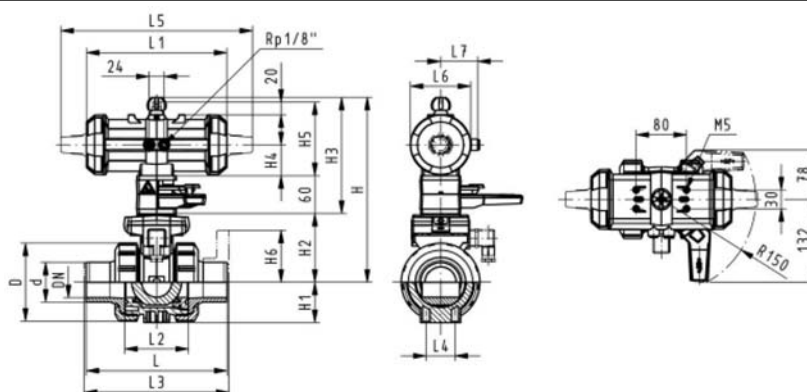

PF 3 39 696



DN10/15 - 50

SYGEF® standard
Ball valve type 232
Function FC (Fail safe to close)
Without manual override
With butt fusion spigots metric

E

Model:

- Built on with pneumatic actuator PA11/21
- For easy installation and removal
- Integrated stainless steel mounting inserts
- Control time 90°<) 1-2 s

Option:

- Individual configuration of the valve (see form)

d [mm]	DN [mm]	PN	kv-value ($\Delta p=1$ bar) [l/min]	FPM Code
20	15	10	185	199 232 833
25	20	10	350	199 232 834
32	25	10	700	199 232 835
40	32	10	1000	199 232 836
50	40	10	1600	199 232 837
63	50	10	3100	199 232 838

d [mm]	D [mm]	H [mm]	H1 [mm]	H2 [mm]	H4 [mm]	H5 [mm]	L [mm]	L1 [mm]	L2 [mm]	L4 [mm]	L5 [mm]	L6 [mm]	L7 [mm]
20	50	167	27	62	40	97	130	194	56	25	261	76	48
25	58	176	30	71	40	97	130	194	65	25	261	76	48
32	68	176	36	71	40	97	130	194	71	25	261	76	48
40	84	210	44	84	51	115	130	224	85	45	305	95	59
50	97	210	51	84	51	115	130	224	89	45	305	95	59
63	124	232	64	106	51	115	130	224	101	45	305	95	59

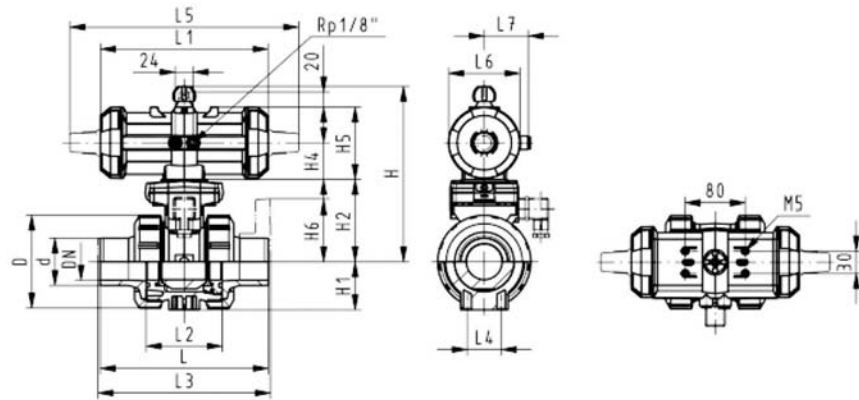

PF 3 39 696



DN10/15 - 50

SYGEF® standard
Ball valve type 232
Function FC (Fail safe to close)
Without manual override
With fusion sockets metric

E

Model:

- Built on with pneumatic actuator PA11/21
- For easy installation and removal
- Integrated stainless steel mounting inserts
- Control time 90°<) 1-2 s

Option:

- Individual configuration of the valve (see form)

d [mm]	DN [mm]	PN	kv-value ($\Delta p=1$ bar) [l/min]	FPM Code	kg
16	10	10	70	199 232 132	1.200
20	15	10	185	199 232 133	1.200
25	20	10	350	199 232 134	1.300
32	25	10	700	199 232 135	1.400
40	32	10	1000	199 232 136	2.500
50	40	10	1600	199 232 137	2.800
63	50	10	3100	199 232 138	3.700

d [mm]	D [mm]	H [mm]	H1 [mm]	H2 [mm]	H4 [mm]	H5 [mm]	L [mm]	L1 [mm]	L2 [mm]	L4 [mm]	L5 [mm]	L6 [mm]	L7 [mm]	z [mm]
16	50	167	27	62	40	97	92	194	56	25	261	76	48	64
20	50	167	27	62	40	97	95	194	56	25	261	76	48	64
25	58	176	30	71	40	97	110	194	65	25	261	76	48	72
32	68	176	36	71	40	97	123	194	71	25	261	76	48	79
40	84	210	44	84	51	115	146	224	85	45	305	95	59	94
50	97	210	51	84	51	115	157	224	89	45	305	95	59	95
63	124	232	64	106	51	115	183	224	101	45	305	95	59	107

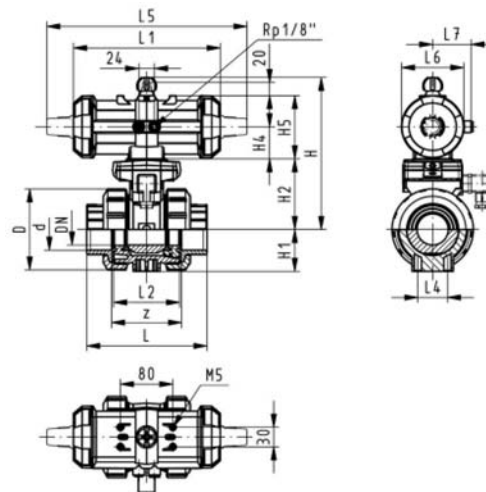

PF 3 39 696



DN10/15 - 50

SYGEF® standard
Ball valve type 232
Function FC (Fail safe to close)
Without manual override
With fusion spigots metric

E

Model:

- Built on with pneumatic actuator PA11/21
- For easy installation and removal
- Integrated stainless steel mounting inserts
- Control time 90°<) 1-2 s

Option:

- Individual configuration of the valve (see form)

d [mm]	DN [mm]	PN	kv-value ($\Delta p=1$ bar) [l/min]	FPM Code	kg
16	10	10	70	199 232 152	1.200
20	15	10	185	199 232 153	1.200
25	20	10	350	199 232 154	1.300
32	25	10	700	199 232 155	1.400
40	32	10	1000	199 232 156	2.500
50	40	10	1600	199 232 157	2.800
63	50	10	3100	199 232 158	3.700

d [mm]	D [mm]	H [mm]	H1 [mm]	H2 [mm]	H4 [mm]	H5 [mm]	L [mm]	L1 [mm]	L2 [mm]	L3 [mm]	L4 [mm]	L5 [mm]	L6 [mm]	L7 [mm]
16	50	167	27	62	40	97	114	194	56	130	25	261	76	48
20	50	167	27	62	40	97	124	194	56	130	25	261	76	48
25	58	176	30	71	40	97	144	194	65	150	25	261	76	48
32	68	176	36	71	40	97	154	194	71	160	25	261	76	48
40	84	210	44	84	51	115	174	224	85	180	45	305	95	59
50	97	210	51	84	51	115	194	224	89	200	45	305	95	59
63	124	232	64	106	51	115	224	224	101	230	45	305	95	59

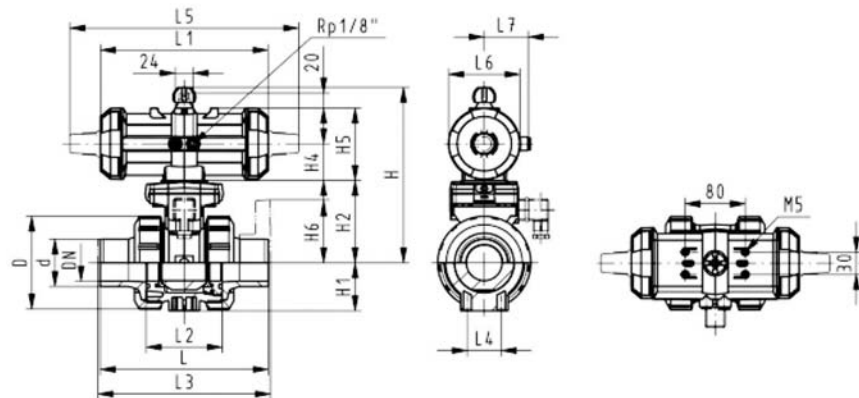

PF 3 39 696



DN10/15 - 50

SYGEF® standard
Ball valve type 232
Function FC (Fail safe to close)
Without manual override
With fixed flanges PVDF serrated metric

E

Model:

- Built on with pneumatic actuator PA11/21
- For easy installation and removal
- Integrated stainless steel mounting inserts
- Control time 90°<) 1-2 s
- Overall length EN 558-1
- Connecting dimensions: ISO 7005 / EN 1092 / DIN 2501 PN10 / BS4504

Option:

- Individual configuration of the valve (see form)

d [mm]	DN [mm]	Inch	PN	kv-value ($\Delta p=1$ bar) [l/min]	FPM Code	kg
20	15	½	10	185	199 232 063	1.400
25	20	¾	10	350	199 232 064	1.600
32	25	1	10	700	199 232 065	1.800
40	32	1 ¼	10	1000	199 232 066	3.100
50	40	1 ½	10	1600	199 232 067	3.600
63	50	2	10	3100	199 232 068	4.700

d [mm]	D [mm]	H [mm]	H1 [mm]	H2 [mm]	H4 [mm]	H5 [mm]	H6 [mm]	L [mm]	L1 [mm]	L2 [mm]	L3 [mm]	L4 [mm]	L5 [mm]	L6 [mm]	L7 [mm]
20	50	167	27	62	40	97	48	124	194	56	130	25	261	76	48
25	58	176	30	71	40	97	53	144	194	65	150	25	261	76	48
32	68	176	36	71	40	97	58	154	194	71	160	25	261	76	48
40	84	210	44	84	51	115	70	174	224	85	180	45	305	95	59
50	97	210	51	84	51	115	75	194	224	89	200	45	305	95	59
63	124	232	64	106	51	115	83	224	224	101	230	45	305	95	59

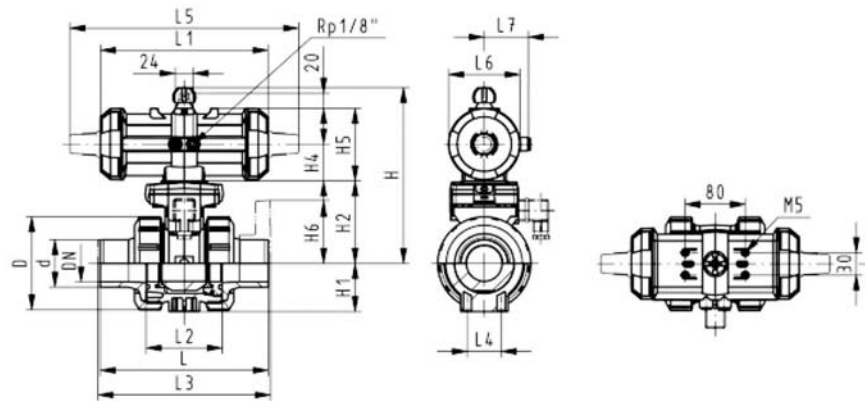

PF 3 39 696



DN10/15 - 50

SYGEF® standard
Ball valve type 232
Function FO (Fail safe to open)
Without manual override
With butt fusion spigots metric

E

Model:

- Built on with pneumatic actuator PA11/21
- For easy installation and removal
- Integrated stainless steel mounting inserts
- Control time 90°<) 1-2 s

Option:

- Individual configuration of the valve (see form)

d [mm]	DN [mm]	PN	kv-value ($\Delta p=1$ bar) [l/min]	FPM Code
20	15	10	185	199 232 873
25	20	10	350	199 232 874
32	25	10	700	199 232 875
40	32	10	1000	199 232 876
50	40	10	1600	199 232 877
63	50	10	3100	199 232 878

d [mm]	D [mm]	H [mm]	H1 [mm]	H2 [mm]	H4 [mm]	H5 [mm]	L [mm]	L1 [mm]	L2 [mm]	L4 [mm]	L5 [mm]	L6 [mm]	L7 [mm]
20	50	167	27	62	40	97	130	194	56	25	261	76	48
25	58	176	30	71	40	97	130	194	65	25	261	76	48
32	68	176	36	71	40	97	130	194	71	25	261	76	48
40	84	210	44	84	51	115	130	224	85	45	305	95	59
50	97	210	51	84	51	115	130	224	89	45	305	95	59
63	124	232	64	106	51	115	130	224	101	45	305	95	59

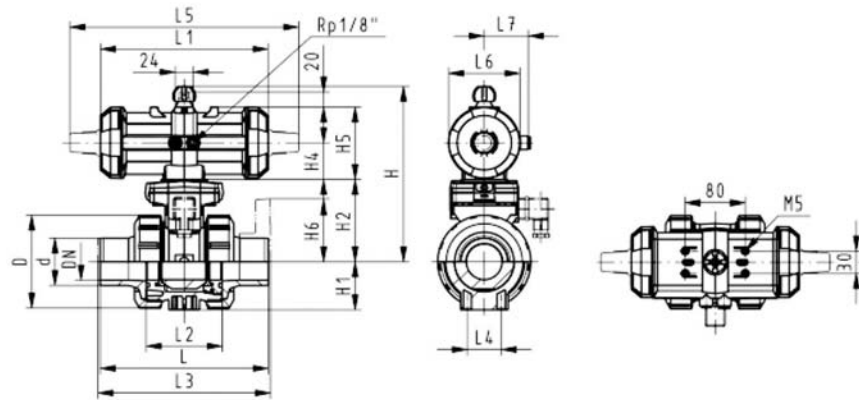

PF 3 39 696



DN10/15 - 50

SYGEF® standard
Ball valve type 232
Function FO (Fail safe to open)
Without manual override
With fusion sockets metric

E

Model:

- Built on with pneumatic actuator PA11/21
- For easy installation and removal
- Integrated stainless steel mounting inserts
- Control time 90°<) 1-2 s

Option:

- Individual configuration of the valve (see form)

d [mm]	DN [mm]	PN	kv-value ($\Delta p=1$ bar) [l/min]	FPM Code	kg
16	10	10	70	199 232 172	1.200
20	15	10	185	199 232 173	1.200
25	20	10	350	199 232 174	1.300
32	25	10	700	199 232 175	1.400
40	32	10	1000	199 232 176	2.500
50	40	10	1600	199 232 177	2.800
63	50	10	3100	199 232 178	3.700

d [mm]	D [mm]	H [mm]	H1 [mm]	H2 [mm]	H4 [mm]	H5 [mm]	L [mm]	L1 [mm]	L2 [mm]	L4 [mm]	L5 [mm]	L6 [mm]	L7 [mm]	z [mm]
16	50	167	27	62	40	97	92	194	56	25	261	76	48	64
20	50	167	27	62	40	97	95	194	56	25	261	76	48	64
25	58	176	30	71	40	97	110	194	65	25	261	76	48	72
32	68	176	36	71	40	97	123	194	71	25	261	76	48	79
40	84	210	44	84	51	115	146	224	85	45	305	95	59	94
50	97	210	51	84	51	115	157	224	89	45	305	95	59	95
63	124	232	64	106	51	115	183	224	101	45	305	95	59	107

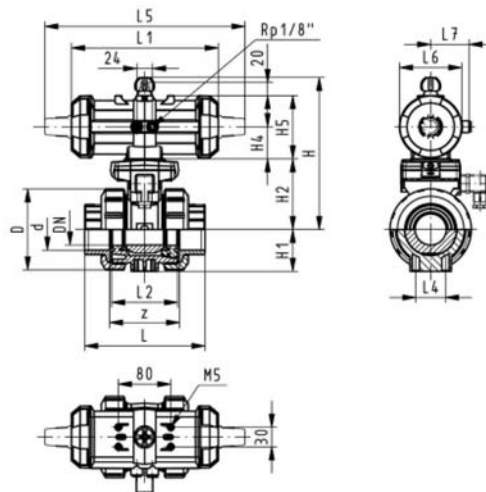

PF 3 39 696



DN10/15 - 50

SYGEF® standard
Ball valve type 232
Function FO (Fail safe to open)
Without manual override
With fusion spigots metric

E

Model:

- Built on with pneumatic actuator PA11/21
- For easy installation and removal
- Integrated stainless steel mounting inserts
- Control time 90°<) 1-2 s

Option:

- Individual configuration of the valve (see form)

d [mm]	DN [mm]	PN	kv-value ($\Delta p=1$ bar) [l/min]	FPM Code	kg
16	10	10	70	199 232 192	1.200
20	15	10	185	199 232 193	1.200
25	20	10	350	199 232 194	1.300
32	25	10	700	199 232 195	1.400
40	32	10	1000	199 232 196	2.500
50	40	10	1600	199 232 197	2.800
63	50	10	3100	199 232 198	3.700

d [mm]	D [mm]	H [mm]	H1 [mm]	H2 [mm]	H4 [mm]	H5 [mm]	L [mm]	L1 [mm]	L2 [mm]	L3 [mm]	L4 [mm]	L5 [mm]	L6 [mm]	L7 [mm]
16	50	167	27	62	40	97	114	194	56	130	25	261	76	48
20	50	167	27	62	40	97	124	194	56	130	25	261	76	48
25	58	176	30	71	40	97	144	194	65	150	25	261	76	48
32	68	176	36	71	40	97	154	194	71	160	25	261	76	48
40	84	210	44	84	51	115	174	224	85	180	45	305	95	59
50	97	210	51	84	51	115	194	224	89	200	45	305	95	59
63	124	232	64	106	51	115	224	224	101	230	45	305	95	59

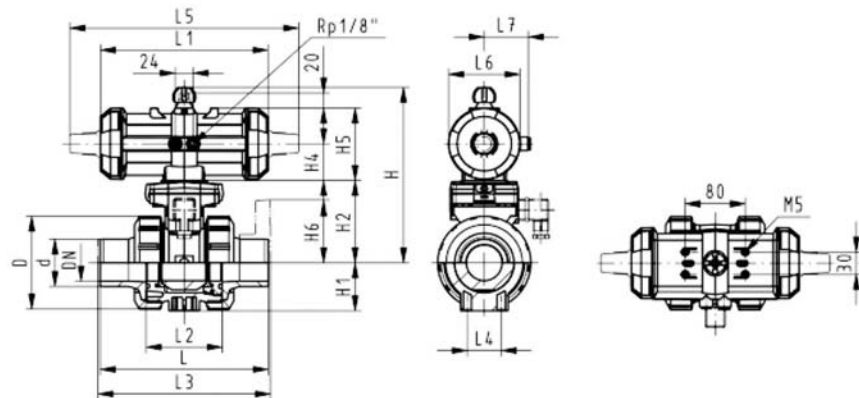

PF 3 39 696



DN10/15 - 50

SYGEF® standard
Ball valve type 232
Function FO (Fail safe to open)
Without manual override
With fixed flanges PVDF serrated metric

E

Model:

- Built on with pneumatic actuator PA11/21
- For easy installation and removal
- Integrated stainless steel mounting inserts
- Control time 90°<) 1-2 s
- Overall length EN 558-1
- Connecting dimensions: ISO 7005 / EN 1092 / DIN 2501 PN10 / BS4504

Option:

- Individual configuration of the valve (see form)

d [mm]	DN [mm]	Inch	PN	kv-value ($\Delta p=1$ bar) [l/min]	FPM Code	kg
20	15	½	10	185	199 232 083	1.400
25	20	¾	10	350	199 232 084	1.600
32	25	1	10	700	199 232 085	1.800
40	32	1 ¼	10	1000	199 232 086	3.100
50	40	1 ½	10	1600	199 232 087	3.600
63	50	2	10	3100	199 232 088	4.700

d [mm]	D [mm]	H [mm]	H1 [mm]	H2 [mm]	H4 [mm]	H5 [mm]	H6 [mm]	L [mm]	L1 [mm]	L2 [mm]	L3 [mm]	L4 [mm]	L5 [mm]	L6 [mm]	L7 [mm]
20	50	167	27	62	40	97	48	124	194	56	130	25	261	76	48
25	58	176	30	71	40	97	53	144	194	65	150	25	261	76	48
32	68	176	36	71	40	97	58	154	194	71	160	25	261	76	48
40	84	210	44	84	51	115	70	174	224	85	180	45	305	95	59
50	97	210	51	84	51	115	75	194	224	89	200	45	305	95	59
63	124	232	64	106	51	115	83	224	224	101	230	45	305	95	59

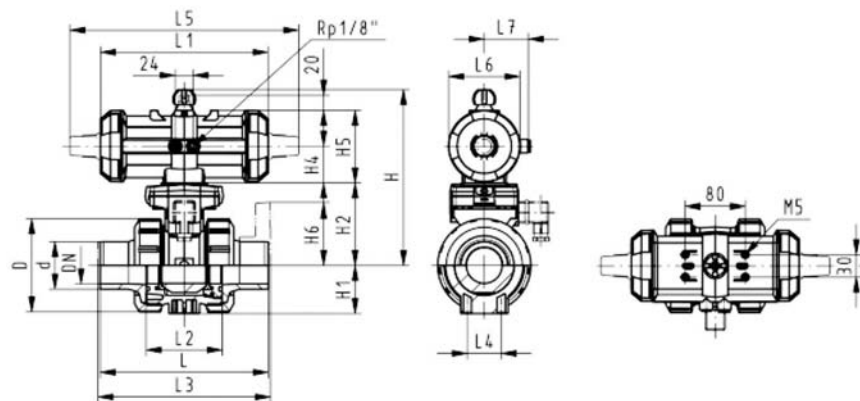

PF 3 39 696



DN10/15 - 50

SYGEF® standard
Ball valve type 232
Function DA (Double acting)
Without manual override
With butt fusion spigots metric

E

Model:

- Built on with pneumatic actuator PA11/21
- For easy installation and removal
- Integrated stainless steel mounting inserts
- Control time 90°<) 1-2 s

Option:

- Individual configuration of the valve (see form)

d [mm]	DN [mm]	PN	kv-value ($\Delta p=1$ bar) [l/min]	FPM Code
20	15	10	185	199 232 913
25	20	10	350	199 232 914
32	25	10	700	199 232 915
40	32	10	1000	199 232 916
50	40	10	1600	199 232 917
63	50	10	3100	199 232 918

d [mm]	D [mm]	H [mm]	H1 [mm]	H2 [mm]	H4 [mm]	H5 [mm]	L [mm]	L1 [mm]	L2 [mm]	L4 [mm]	L5 [mm]	L6 [mm]	L7 [mm]
20	50	167	27	62	40	97	130	194	56	25	261	76	48
25	58	176	30	71	40	97	130	194	65	25	261	76	48
32	68	176	36	71	40	97	130	194	71	25	261	76	48
40	84	210	44	84	51	115	130	224	85	45	305	95	59
50	97	210	51	84	51	115	130	224	89	45	305	95	59
63	124	232	64	106	51	115	130	224	101	45	305	95	59

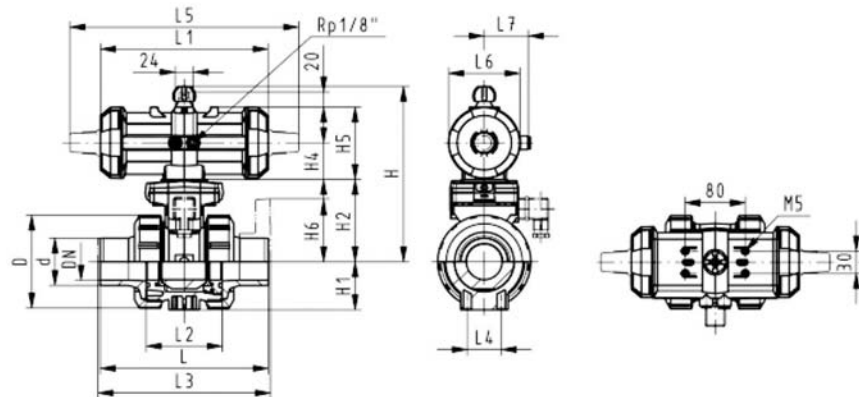

PF 3 39 696



DN10/15 - 50

SYGEF® standard
Ball valve type 232
Function DA (Double acting)
Without manual override
With fusion sockets metric

E

Model:

- Built on with pneumatic actuator PA11/21
- For easy installation and removal
- Integrated stainless steel mounting inserts
- Control time 90°<) 1-2 s

Option:

- Individual configuration of the valve (see form)

d [mm]	DN [mm]	PN	kv-value ($\Delta p=1$ bar) [l/min]	FPM Code	kg
16	10	10	70	199 232 212	1.200
20	15	10	185	199 232 213	1.200
25	20	10	350	199 232 214	1.300
32	25	10	700	199 232 215	1.400
40	32	10	1000	199 232 216	2.500
50	40	10	1600	199 232 217	2.800
63	50	10	3100	199 232 218	3.700

d [mm]	D [mm]	H [mm]	H1 [mm]	H2 [mm]	H4 [mm]	H5 [mm]	L [mm]	L1 [mm]	L2 [mm]	L4 [mm]	L5 [mm]	L6 [mm]	L7 [mm]	z [mm]
16	50	167	27	62	40	97	92	194	56	25	261	76	48	64
20	50	167	27	62	40	97	95	194	56	25	261	76	48	64
25	58	176	30	71	40	97	110	194	65	25	261	76	48	72
32	68	176	36	71	40	97	123	194	71	25	261	76	48	79
40	84	210	44	84	51	115	146	224	85	45	305	95	59	94
50	97	210	51	84	51	115	157	224	89	45	305	95	59	95
63	124	232	64	106	51	115	183	224	101	45	305	95	59	107

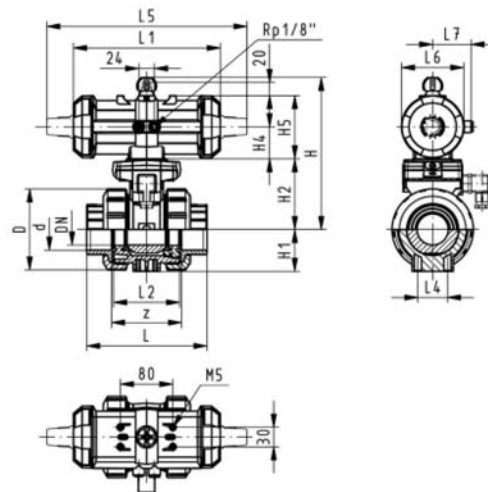

PF 3 39 696



DN10/15 - 50

SYGEF® standard
Ball valve type 232
Function DA (Double acting)
Without manual override
With fusion spigots metric

E

Model:

- Built on with pneumatic actuator PA11/21
- For easy installation and removal
- Integrated stainless steel mounting inserts
- Control time 90°<) 1-2 s

Option:

- Individual configuration of the valve (see form)

d [mm]	DN [mm]	PN	kv-value ($\Delta p=1$ bar) [l/min]	FPM Code	kg
16	10	10	70	199 232 232	1.200
20	15	10	185	199 232 233	1.200
25	20	10	350	199 232 234	1.300
32	25	10	700	199 232 235	1.400
40	32	10	1000	199 232 236	2.500
50	40	10	1600	199 232 237	2.800
63	50	10	3100	199 232 238	3.700

d [mm]	D [mm]	H [mm]	H1 [mm]	H2 [mm]	H4 [mm]	H5 [mm]	L [mm]	L1 [mm]	L2 [mm]	L3 [mm]	L4 [mm]	L5 [mm]	L6 [mm]	L7 [mm]
16	50	167	27	62	40	97	114	194	56	130	25	261	76	48
20	50	167	27	62	40	97	124	194	56	130	25	261	76	48
25	58	176	30	71	40	97	144	194	65	150	25	261	76	48
32	68	176	36	71	40	97	154	194	71	160	25	261	76	48
40	84	210	44	84	51	115	174	224	85	180	45	305	95	59
50	97	210	51	84	51	115	194	224	89	200	45	305	95	59
63	124	232	64	106	51	115	224	224	101	230	45	305	95	59

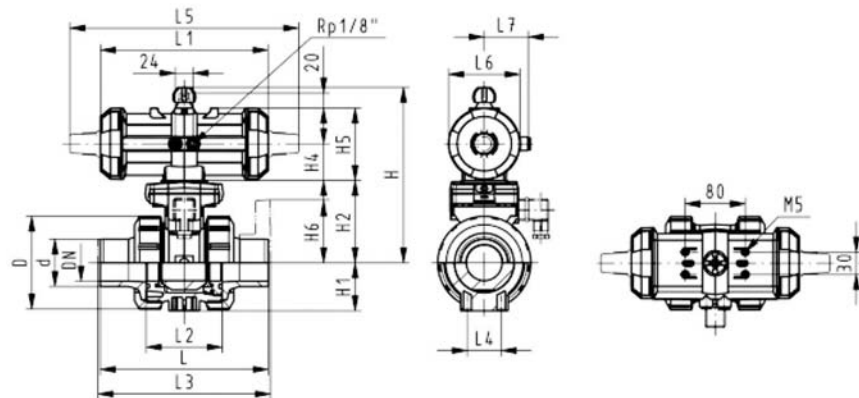

PF 3 39 696



DN10/15 - 50

SYGEF® standard
Ball valve type 232
Function DA (Double acting)
Without manual override
With fixed flanges PVDF serrated metric

E

Model:

- Built on with pneumatic actuator PA11/21
- For easy installation and removal
- Integrated stainless steel mounting inserts
- Control time 90°<) 1-2 s
- Overall length EN 558-1
- Connecting dimensions: ISO 7005 / EN 1092 / DIN 2501 PN10 / BS4504

Option:

- Individual configuration of the valve (see form)

d [mm]	DN [mm]	Inch	PN	kv-value ($\Delta p=1$ bar) [l/min]	FPM Code	kg
20	15	½	10	185	199 232 103	1.400
25	20	¾	10	350	199 232 104	1.600
32	25	1	10	700	199 232 105	1.800
40	32	1 ¼	10	1000	199 232 106	3.100
50	40	1 ½	10	1600	199 232 107	3.600
63	50	2	10	3100	199 232 108	4.700

d [mm]	D [mm]	H [mm]	H1 [mm]	H2 [mm]	H4 [mm]	H5 [mm]	H6 [mm]	L [mm]	L1 [mm]	L2 [mm]	L3 [mm]	L4 [mm]	L5 [mm]	L6 [mm]	L7 [mm]
20	50	167	27	62	40	97	48	124	194	56	130	25	261	76	48
25	58	176	30	71	40	97	53	144	194	65	150	25	261	76	48
32	68	176	36	71	40	97	58	154	194	71	160	25	261	76	48
40	84	210	44	84	51	115	70	174	224	85	180	45	305	95	59
50	97	210	51	84	51	115	75	194	224	89	200	45	305	95	59
63	124	232	64	106	51	115	83	224	224	101	230	45	305	95	59

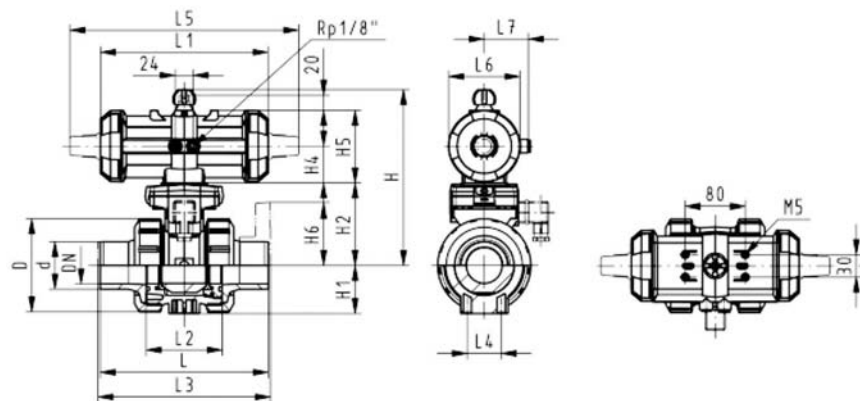

PF 3 39 696

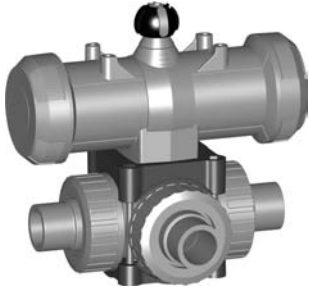

SYGEF® standard
3-Way ball valve type 277
Horizontal/L-port
Without manual override
With butt fusion spigots IR metric

Model:

- Built on with pneumatic actuator PA11/21
- Actuator fails safe to the closed position FC
- For easy installation and removal
- Integrated stainless steel mounting inserts
- Control time 90°<) 1-3 s

d [mm]	DN [mm]	PN	kv-value ($\Delta p=1$ bar) [l/min]	FPM Code	kg
16	10	10	50	199 277 052	1.171
20	15	10	75	199 277 053	1.170
25	20	10	150	199 277 054	1.167
32	25	10	280	199 277 055	1.677
40	32	10	480	199 277 056	2.722
50	40	10	620	199 277 057	2.555
63	50	10	1230	199 277 058	3.487

d [mm]	D [mm]	H [mm]	H1 [mm]	H2 [mm]	H3 [mm]	H4 [mm]	H5 [mm]	H6 [mm]	L [mm]	L1 [mm]	L2 [mm]	L3 [mm]	L4 [mm]	L5 [mm]	L6 [mm]
16	46	136	29	31	105	40	77	8	119	194	70	36	25	261	73
20	46	136	29	31	105	40	77	8	133	194	70	36	25	261	73
25	56	144	33	39	105	40	77	8	155	194	86	43	25	261	73
32	67	149	38	44	105	40	77	8	170	194	96	48	25	261	73
40	82	177	44	50	127	51	99	9	201	224	114	58	45	305	94
50	98	190	50	63	127	51	99	9	236	224	137	69	45	305	94
63	121	203	61	76	127	51	99	9	286	224	179	90	45	305	94

d [mm]	L7 [mm]	M
16	48	6
20	48	6
25	48	6
32	48	6
40	59	8
50	59	8
63	59	8

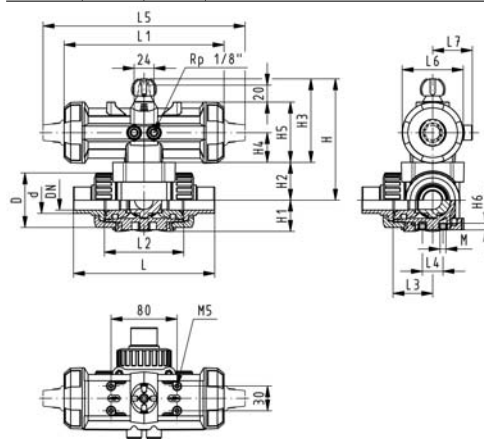

PF 3 39 750

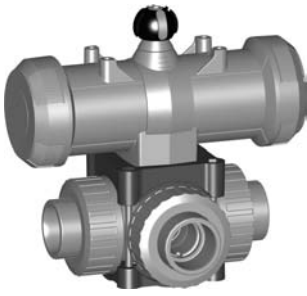

SYGEF® standard
3-Way ball valve type 277
Horizontal/L-port
Without manual override
With fusion sockets

Model:

- Built on with pneumatic actuator PA11/21
- Actuator fails safe to the closed position FC
- For easy installation and removal
- Integrated stainless steel mounting inserts
- Control time 90°<) 1-3 s

d [mm]	DN [mm]	PN	kv-value ($\Delta p=1$ bar) [l/min]	FPM Code	kg
16	10	10	50	199 277 092	1.171
20	15	10	75	199 277 093	1.171
25	20	10	150	199 277 094	1.401
32	25	10	280	199 277 095	1.290
40	32	10	480	199 277 096	2.191
50	40	10	620	199 277 097	2.555
63	50	10	1230	199 277 098	3.487

d [mm]	D [mm]	H [mm]	H1 [mm]	H2 [mm]	H3 [mm]	H4 [mm]	H5 [mm]	H6 [mm]	L [mm]	L1 [mm]	L2 [mm]	L3 [mm]	L4 [mm]	L5 [mm]	L6 [mm]
16	46	136	29	31	105	40	77	8	119	194	70	36	25	261	73
20	46	136	29	31	105	40	77	8	133	194	70	36	25	261	73
25	56	144	33	39	105	40	77	8	155	194	86	43	25	261	73
32	67	149	38	44	105	40	77	8	170	194	96	48	25	261	73
40	82	177	44	50	127	51	99	9	201	224	114	58	45	305	94
50	98	190	50	63	127	51	99	9	236	224	137	69	45	305	94
63	121	203	61	76	127	51	99	9	286	224	179	90	45	305	94

d [mm]	L7 [mm]	M
16	48	6
20	48	6
25	48	6
32	48	6
40	59	8
50	59	8
63	59	8

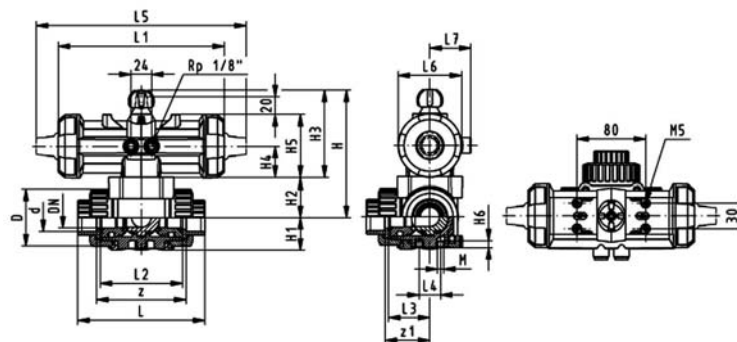

PF 3 39 750

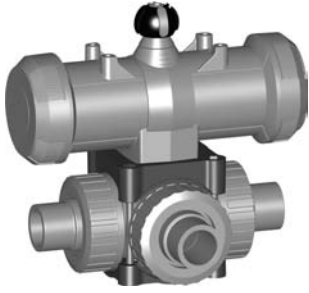

SYGEF® standard
3-Way ball valve type 277
Horizontal/L-port
Without manual override
With socket fusion spigots

Model:

- Built on with pneumatic actuator PA11/21
- Actuator fails safe to the closed position FC
- For easy installation and removal
- Integrated stainless steel mounting inserts
- Control time 90°<) 1-3 s

d [mm]	DN [mm]	PN	kv-value ($\Delta p=1$ bar) [l/min]	FPM Code	kg
16	10	10	50	199 277 012	1.171
20	15	10	75	199 277 013	1.171
25	20	10	150	199 277 014	1.401
32	25	10	280	199 277 015	1.611
40	32	10	480	199 277 016	2.722
50	40	10	620	199 277 017	3.413
63	50	10	1230	199 277 018	5.137

d [mm]	D [mm]	H [mm]	H1 [mm]	H2 [mm]	H3 [mm]	H4 [mm]	H5 [mm]	H6 [mm]	L [mm]	L1 [mm]	L2 [mm]	L3 [mm]	L4 [mm]	L5 [mm]	L6 [mm]
16	46	136	29	31	105	40	77	8	119	194	70	36	25	261	73
20	46	136	29	31	105	40	77	8	133	194	70	36	25	261	73
25	56	144	33	39	105	40	77	8	155	194	86	43	25	261	73
32	67	149	38	44	105	40	77	8	170	194	96	48	25	261	73
40	82	177	44	50	127	51	99	9	201	224	114	58	45	305	94
50	98	190	50	63	127	51	99	9	236	224	137	69	45	305	94
63	121	203	61	76	127	51	99	9	286	224	179	90	45	305	94

d [mm]	L7 [mm]	M
16	48	6
20	48	6
25	48	6
32	48	6
40	59	8
50	59	8
63	59	8

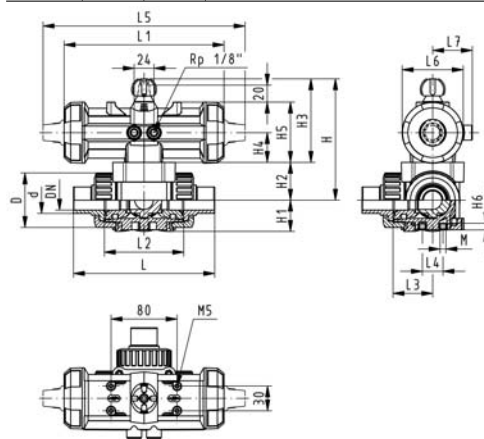

PF 3 39 750

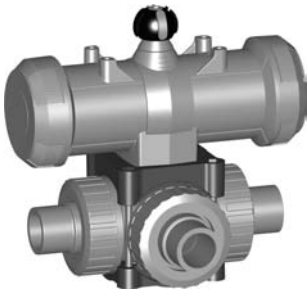

SYGEF® standard
3-Way ball valve type 277
Horizontal/L-port DA (Double acting)
Without manual override
With butt fusion spigots IR metric

E

Model:

- Built on with pneumatic actuator PA11/21
- For easy installation and removal
- Integrated stainless steel mounting inserts
- Control time 90°<) 1-3 s

d [mm]	DN [mm]	PN	kv-value ($\Delta p=1$ bar) [l/min]	FPM Code	kg
16	10	10	50	199 277 172	0.981
20	15	10	75	199 277 173	0.981
25	20	10	150	199 277 174	1.211
32	25	10	280	199 277 175	1.100
40	32	10	480	199 277 176	2.131
50	40	10	620	199 277 177	2.989
63	50	10	1230	199 277 178	4.700

d [mm]	D [mm]	H [mm]	H1 [mm]	H2 [mm]	H3 [mm]	H4 [mm]	H5 [mm]	H6 [mm]	L [mm]	L1 [mm]	L2 [mm]	L3 [mm]	L4 [mm]	L5 [mm]	L6 [mm]
16	46	136	29	31	105	40	77	8	119	194	70	36	25	261	73
20	46	136	29	31	105	40	77	8	133	194	70	36	25	261	73
25	56	144	33	39	105	40	77	8	155	194	86	43	25	261	73
32	67	149	38	44	105	40	77	8	170	194	96	48	25	261	73
40	82	177	44	50	127	51	99	9	201	224	114	58	45	305	94
50	98	190	50	63	127	51	99	9	236	224	137	69	45	305	94
63	121	203	61	76	127	51	99	9	286	224	179	90	45	305	94

d [mm]	L7 [mm]	M
16	48	6
20	48	6
25	48	6
32	48	6
40	59	8
50	59	8
63	59	8

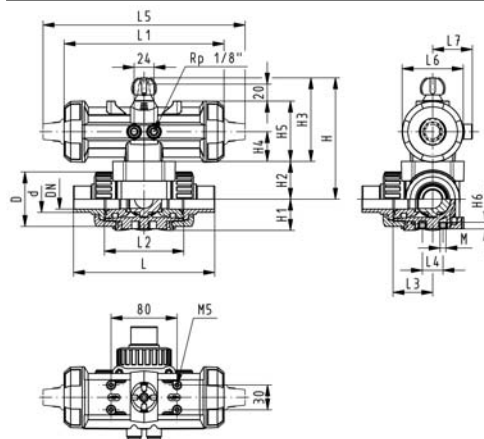

PF 3 39 750

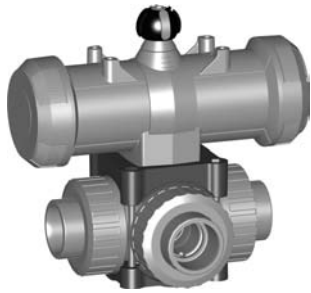

SYGEF® standard
3-Way ball valve type 277
Horizontal/L-port DA (Double acting)
Without manual override
With fusion sockets

E

Model:

- Built on with pneumatic actuator PA11/21
- For easy installation and removal
- Integrated stainless steel mounting inserts
- Control time $90^\circ <$ 1-3 s

d [mm]	DN [mm]	PN	kv-value ($\Delta p=1$ bar) [l/min]	FPM Code	kg
16	10	10	50	199 277 212	0.981
20	15	10	75	199 277 213	0.981
25	20	10	150	199 277 214	1.211
32	25	10	280	199 277 215	1.421
40	32	10	480	199 277 216	2.298
50	40	10	620	199 277 217	2.989
63	50	10	1230	199 277 218	5.052

d [mm]	D [mm]	H [mm]	H1 [mm]	H2 [mm]	H3 [mm]	H4 [mm]	H5 [mm]	H6 [mm]	L [mm]	L1 [mm]	L2 [mm]	L3 [mm]	L4 [mm]	L5 [mm]	L6 [mm]
16	46	136	29	31	105	40	77	8	119	194	70	36	25	261	73
20	46	136	29	31	105	40	77	8	133	194	70	36	25	261	73
25	56	144	33	39	105	40	77	8	155	194	86	43	25	261	73
32	67	149	38	44	105	40	77	8	170	194	96	48	25	261	73
40	82	177	44	50	127	51	99	9	201	224	114	58	45	305	94
50	98	190	50	63	127	51	99	9	236	224	137	69	45	305	94
63	121	203	61	76	127	51	99	9	286	224	179	90	45	305	94

d [mm]	L7 [mm]	M
16	48	6
20	48	6
25	48	6
32	48	6
40	59	8
50	59	8
63	59	8

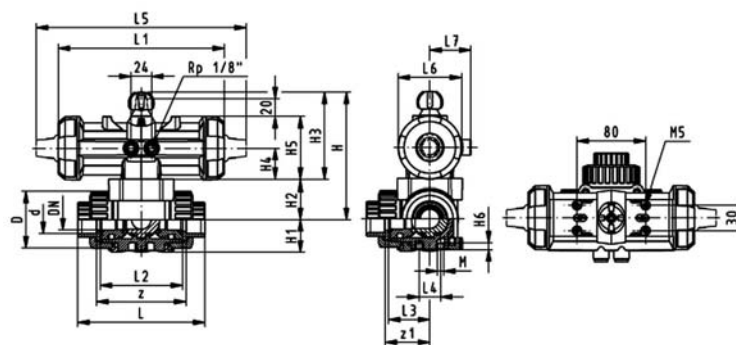

PF 3 39 750

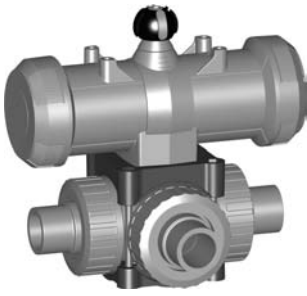

SYGEF® standard
3-Way ball valve type 277
Horizontal/L-port DA (Double acting)
Without manual override
With socket fusion spigots

E

Model:

- Built on with pneumatic actuator PA11/21
- For easy installation and removal
- Integrated stainless steel mounting inserts
- Control time 90°<) 1-3 s

d [mm]	DN [mm]	PN	kv-value ($\Delta p=1$ bar) [l/min]	FPM Code	kg
16	10	10	50	199 277 132	0.924
20	15	10	75	199 277 133	0.981
25	20	10	150	199 277 134	1.211
32	25	10	280	199 277 135	1.421
40	32	10	480	199 277 136	2.298
50	40	10	620	199 277 137	2.989
63	50	10	1230	199 277 138	4.713

d [mm]	D [mm]	H [mm]	H1 [mm]	H2 [mm]	H3 [mm]	H4 [mm]	H5 [mm]	H6 [mm]	L [mm]	L1 [mm]	L2 [mm]	L3 [mm]	L4 [mm]	L5 [mm]	L6 [mm]
16	46	136	29	31	105	40	77	8	119	194	70	36	25	261	73
20	46	136	29	31	105	40	77	8	133	194	70	36	25	261	73
25	56	144	33	39	105	40	77	8	155	194	86	43	25	261	73
32	67	149	38	44	105	40	77	8	170	194	96	48	25	261	73
40	82	177	44	50	127	51	99	9	201	224	114	58	45	305	94
50	98	190	50	63	127	51	99	9	236	224	137	69	45	305	94
63	121	203	61	76	127	51	99	9	286	224	179	90	45	305	94

d [mm]	L7 [mm]	M
16	48	6
20	48	6
25	48	6
32	48	6
40	59	8
50	59	8
63	59	8

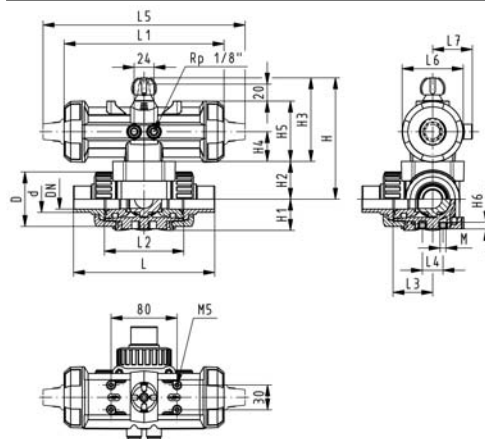

PF 3 39 750

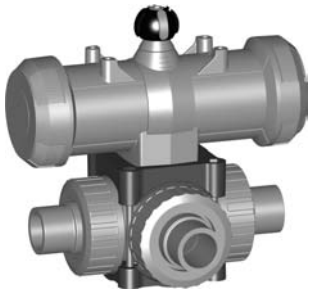

SYGEF® standard
3-Way ball valve type 277
Horizontal/T-port
Without manual override
With butt fusion spigots IR metric

Model:

- Built on with pneumatic actuator PA11/21
- Actuator fails safe to the closed position FC
- For easy installation and removal
- Integrated stainless steel mounting inserts
- Control time 90°<) 1-3 s

d [mm]	DN [mm]	PN	kv-value ($\Delta p=1$ bar) [l/min]	FPM Code	kg
16	10	10	140	199 277 072	1.171
20	15	10	200	199 277 073	1.044
25	20	10	470	199 277 074	1.401
32	25	10	793	199 277 075	1.611
40	32	10	1290	199 277 076	2.722
50	40	10	1910	199 277 077	3.410
63	50	10	3100	199 277 078	3.487

d [mm]	D [mm]	H [mm]	H1 [mm]	H2 [mm]	H3 [mm]	H4 [mm]	H5 [mm]	H6 [mm]	L [mm]	L1 [mm]	L2 [mm]	L3 [mm]	L4 [mm]	L5 [mm]	L6 [mm]
16	46	136	29	31	105	40	77	8	119	194	70	36	25	261	73
20	46	136	29	31	105	40	77	8	133	194	70	36	25	261	73
25	56	144	33	39	105	40	77	8	155	194	86	43	25	261	73
32	67	149	38	44	105	40	77	8	170	194	96	48	25	261	73
40	82	177	44	50	127	51	99	9	201	224	114	58	45	305	94
50	98	190	50	63	127	51	99	9	236	224	137	69	45	305	94
63	121	203	61	76	127	51	99	9	286	224	179	90	45	305	94

d [mm]	L7 [mm]	M
16	48	6
20	48	6
25	48	6
32	48	6
40	59	8
50	59	8
63	59	8

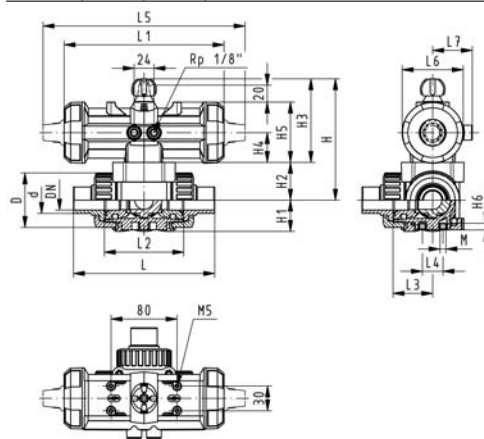

PF 3 39 750

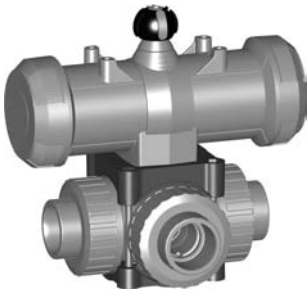

SYGEF® standard
3-Way ball valve type 277
Horizontal/T-port
Without manual override
With fusion sockets

Model:

- Built on with pneumatic actuator PA11/21
- Actuator fails safe to the closed position FC
- For easy installation and removal
- Integrated stainless steel mounting inserts
- Control time 90°<) 1-3 s

d [mm]	DN [mm]	PN	kv-value ($\Delta p=1$ bar) [l/min]	FPM Code	kg
16	10	10	140	199 277 112	1.171
20	15	10	200	199 277 113	1.337
25	20	10	470	199 277 114	1.401
32	25	10	793	199 277 115	1.611
40	32	10	1290	199 277 116	2.722
50	40	10	1910	199 277 117	3.413
63	50	10	3100	199 277 118	5.137

d [mm]	D [mm]	H [mm]	H1 [mm]	H2 [mm]	H3 [mm]	H4 [mm]	H5 [mm]	H6 [mm]	L [mm]	L1 [mm]	L2 [mm]	L3 [mm]	L4 [mm]	L5 [mm]	L6 [mm]
16	46	136	29	31	105	40	77	8	119	194	70	36	25	261	73
20	46	136	29	31	105	40	77	8	133	194	70	36	25	261	73
25	56	144	33	39	105	40	77	8	155	194	86	43	25	261	73
32	67	149	38	44	105	40	77	8	170	194	96	48	25	261	73
40	82	177	44	50	127	51	99	9	201	224	114	58	45	305	94
50	98	190	50	63	127	51	99	9	236	224	137	69	45	305	94
63	121	203	61	76	127	51	99	9	286	224	179	90	45	305	94

d [mm]	L7 [mm]	M
16	48	6
20	48	6
25	48	6
32	48	6
40	59	8
50	59	8
63	59	8

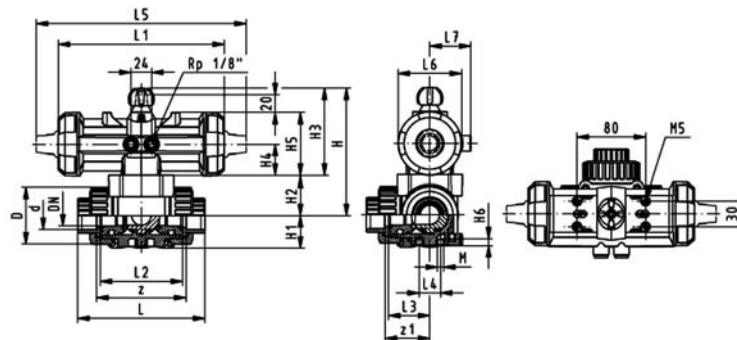

PF 3 39 750

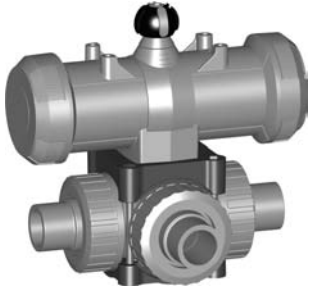

SYGEF® standard
3-Way ball valve type 277
Horizontal/T-port
Without manual override
With socket fusion spigots

Model:

- Built on with pneumatic actuator PA11/21
- Actuator fails safe to the closed position FC
- For easy installation and removal
- Integrated stainless steel mounting inserts
- Control time 90°<) 1-3 s

d [mm]	DN [mm]	PN	kv-value ($\Delta p=1$ bar) [l/min]	FPM Code	kg
16	10	10	140	199 277 032	1.171
20	15	10	200	199 277 033	1.171
25	20	10	470	199 277 034	1.401
32	25	10	793	199 277 035	1.611
40	32	10	1290	199 277 036	2.722
50	40	10	1910	199 277 037	2.555
63	50	10	3100	199 277 038	5.137

d [mm]	D [mm]	H [mm]	H1 [mm]	H2 [mm]	H3 [mm]	H4 [mm]	H5 [mm]	H6 [mm]	L [mm]	L1 [mm]	L2 [mm]	L3 [mm]	L4 [mm]	L5 [mm]	L6 [mm]
16	46	136	29	31	105	40	77	8	119	194	70	36	25	261	73
20	46	136	29	31	105	40	77	8	133	194	70	36	25	261	73
25	56	144	33	39	105	40	77	8	155	194	86	43	25	261	73
32	67	149	38	44	105	40	77	8	170	194	96	48	25	261	73
40	82	177	44	50	127	51	99	9	201	224	114	58	45	305	94
50	98	190	50	63	127	51	99	9	236	224	137	69	45	305	94
63	121	203	61	76	127	51	99	9	286	224	179	90	45	305	94

d [mm]	L7 [mm]	M
16	48	6
20	48	6
25	48	6
32	48	6
40	59	8
50	59	8
63	59	8

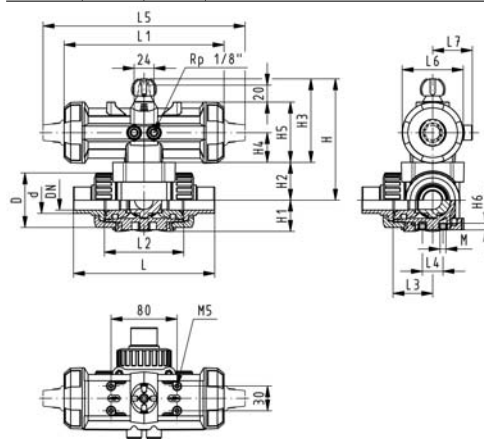

PF 3 39 750

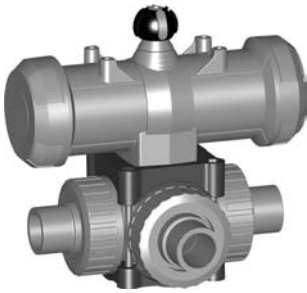

SYGEF® standard
3-Way ball valve type 277
Horizontal/T-port DA (Double acting)
Without manual override
With butt fusion spigots IR metric

Model:

- Built on with pneumatic actuator PA11/21
- For easy installation and removal
- Integrated stainless steel mounting inserts
- Control time 90°<) 1-3 s

d [mm]	DN [mm]	PN	kv-value ($\Delta p=1$ bar) [l/min]	FPM Code	kg
16	10	10	140	199 277 192	0.981
20	15	10	200	199 277 193	0.981
25	20	10	470	199 277 194	1.211
32	25	10	793	199 277 195	1.421
40	32	10	1290	199 277 196	2.298
50	40	10	1910	199 277 197	2.989
63	50	10	3100	199 277 198	3.297

d [mm]	D [mm]	H [mm]	H1 [mm]	H2 [mm]	H3 [mm]	H4 [mm]	H5 [mm]	H6 [mm]	L [mm]	L1 [mm]	L2 [mm]	L3 [mm]	L4 [mm]	L5 [mm]	L6 [mm]
16	46	136	29	31	105	40	77	8	119	194	70	36	25	261	73
20	46	136	29	31	105	40	77	8	133	194	70	36	25	261	73
25	56	144	33	39	105	40	77	8	155	194	86	43	25	261	73
32	67	149	38	44	105	40	77	8	170	194	96	48	25	261	73
40	82	177	44	50	127	51	99	9	201	224	114	58	45	305	94
50	98	190	50	63	127	51	99	9	236	224	137	69	45	305	94
63	121	203	61	76	127	51	99	9	286	224	179	90	45	305	94

d [mm]	L7 [mm]	M
16	48	6
20	48	6
25	48	6
32	48	6
40	59	8
50	59	8
63	59	8

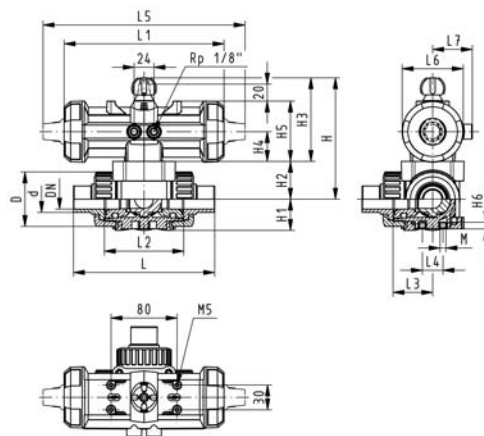

PF 3 39 750

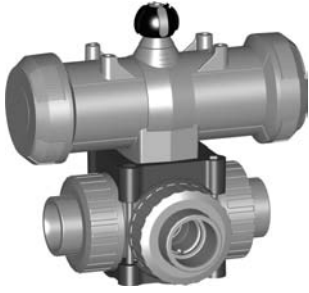

SYGEF® standard
3-Way ball valve type 277
Horizontal/T-port DA (Double acting)
Without manual override
With fusion sockets

Model:

- Built on with pneumatic actuator PA11/21
- For easy installation and removal
- Integrated stainless steel mounting inserts
- Control time 90°< 1-3 s

d [mm]	DN [mm]	PN	kv-value ($\Delta p=1$ bar) [l/min]	FPM Code	kg
16	10	10	140	199 277 232	0.981
20	15	10	200	199 277 233	0.981
25	20	10	470	199 277 234	1.211
32	25	10	793	199 277 235	1.277
40	32	10	1290	199 277 236	2.298
50	40	10	1910	199 277 237	2.989
63	50	10	3100	199 277 238	4.713

d [mm]	D [mm]	H [mm]	H1 [mm]	H2 [mm]	H3 [mm]	H4 [mm]	H5 [mm]	H6 [mm]	L [mm]	L1 [mm]	L2 [mm]	L3 [mm]	L4 [mm]	L5 [mm]	L6 [mm]
16	46	136	29	31	105	40	77	8	119	194	70	36	25	261	73
20	46	136	29	31	105	40	77	8	133	194	70	36	25	261	73
25	56	144	33	39	105	40	77	8	155	194	86	43	25	261	73
32	67	149	38	44	105	40	77	8	170	194	96	48	25	261	73
40	82	177	44	50	127	51	99	9	201	224	114	58	45	305	94
50	98	190	50	63	127	51	99	9	236	224	137	69	45	305	94
63	121	203	61	76	127	51	99	9	286	224	179	90	45	305	94

d [mm]	L7 [mm]	M
16	48	6
20	48	6
25	48	6
32	48	6
40	59	8
50	59	8
63	59	8

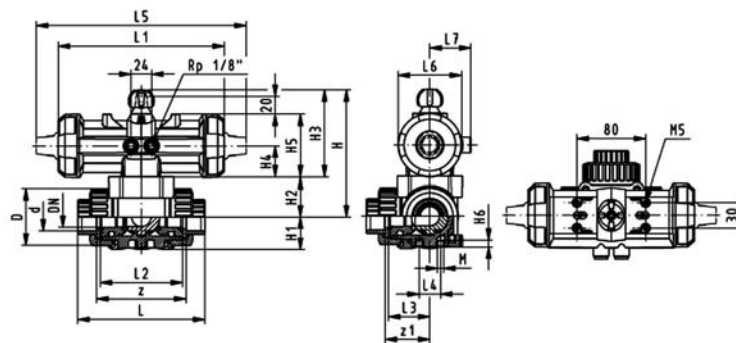

PF 3 39 750

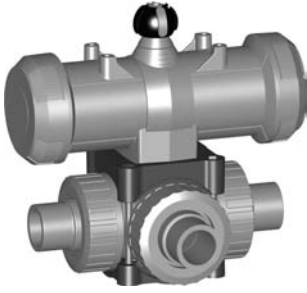

SYGEF® standard
3-Way ball valve type 277
Horizontal/T-port DA (Double acting)
Without manual override
With socket fusion spigots

Model:

- Built on with pneumatic actuator PA11/21
- For easy installation and removal
- Integrated stainless steel mounting inserts
- Control time 90°<) 1-3 s

d [mm]	DN [mm]	PN	kv-value ($\Delta p=1$ bar) [l/min]	FPM Code	kg
16	10	10	140	199 277 152	0.981
20	15	10	200	199 277 153	0.981
25	20	10	470	199 277 154	1.211
32	25	10	793	199 277 155	1.421
40	32	10	1290	199 277 156	2.298
50	40	10	1910	199 277 157	2.989
63	50	10	3100	199 277 158	4.713

d [mm]	D [mm]	H [mm]	H1 [mm]	H2 [mm]	H3 [mm]	H4 [mm]	H5 [mm]	H6 [mm]	L [mm]	L1 [mm]	L2 [mm]	L3 [mm]	L4 [mm]	L5 [mm]	L6 [mm]
16	46	136	29	31	105	40	77	8	119	194	70	36	25	261	73
20	46	136	29	31	105	40	77	8	133	194	70	36	25	261	73
25	56	144	33	39	105	40	77	8	155	194	86	43	25	261	73
32	67	149	38	44	105	40	77	8	170	194	96	48	25	261	73
40	82	177	44	50	127	51	99	9	201	224	114	58	45	305	94
50	98	190	50	63	127	51	99	9	236	224	137	69	45	305	94
63	121	203	61	76	127	51	99	9	286	224	179	90	45	305	94

d [mm]	L7 [mm]	M
16	48	6
20	48	6
25	48	6
32	48	6
40	59	8
50	59	8
63	59	8

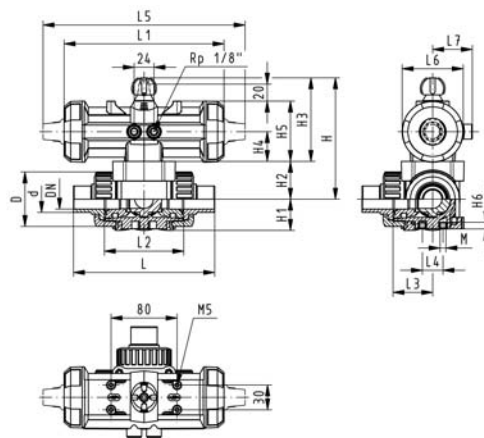

PF 3 39 750

Diaphragm valves pneumatic

SYGEF® standard

Diaphragm valve type DIASTAR 028

Function FC (Fail safe to close)

With butt fusion spigots IR metric

E



- With position indicator / Working pressure: **one side**

d [mm]	DN [mm]	PN	kv-value ($\Delta p=1$ bar) [l/min]	PTFE/EPDM Code	kg
20	15	5	72	199 028 961	0.520
25	20	7	120	199 028 962	0.950
32	25	7	238	199 028 963	1.500
40	32	7	341	199 028 964	1.810
50	40	7	460	199 028 965	3.350
63	50	7	685	199 028 966	6.270

d [mm]	D [mm]	D1_G [inch]	D3[M] [mm]	L [mm]	L1 [mm]	L2 [mm]	H [mm]	H1 [mm]	H2 [mm]	H3 [mm]	H4 [mm]	H5 [mm]	H6 [mm]	H7 [mm]	H8 [mm]
20	68	1/8	6	124	60	25	98	59	24	23	44	100	155	44	76
25	96	1/8	6	144	60	25	127	71	25	23	44	100	155	56	88
32	96	1/8	6	154	60	25	141	85	25	23	44	100	155	56	88
40	120	1/8	8	174	60	45	167	97	26	36	64	100	160	68	100
50	150	1/4	8	194	60	45	198	108	36	36	64	100	170	85	117
63	150	1/4	8	224	60	45	216	126	36	36	64	100	170	85	117

d [mm]	H9 [mm]	H10 [mm]	Lift = Hx [mm]
20	14	12	8
25	18	12	10
32	21	12	12
40	26	15	14
50	33	15	18
63	39	15	22

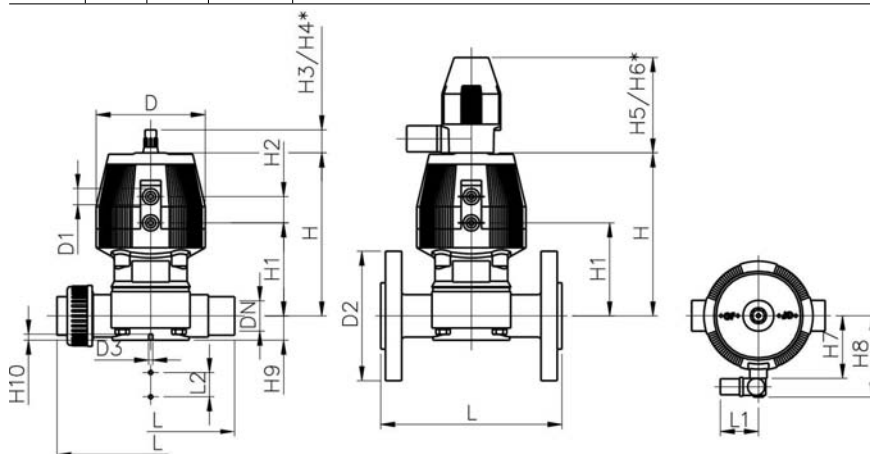

PF 3 39 212



SYGEF® standard
Diaphragm valve type DIASTAR 028
Function FC (Fail safe to close)
Unions with butt fusion spigots IR metric

E

- With position indicator / Working pressure: **one side**

d [mm]	DN [mm]	PN	kv-value ($\Delta p=1$ bar) [l/min]	PTFE/EPDM Code	kg
20	15	5	72	199 028 491	0.530
25	20	7	120	199 028 492	1.000
32	25	7	238	199 028 493	1.390
40	32	7	341	199 028 494	1.870
50	40	7	460	199 028 495	3.030
63	50	7	685	199 028 496	3.880

d [mm]	D [mm]	D1_G [inch]	D3[M] [mm]	L [mm]	L1 [mm]	L2 [mm]	H [mm]	H1 [mm]	H2 [mm]	H3 [mm]	H4 [mm]	H5 [mm]	H6 [mm]	H7 [mm]	H8 [mm]
20	68	1/8	6	196	60	25	98	59	24	23	44	100	155	44	76
25	96	1/8	6	220	60	25	127	71	25	23	44	100	155	56	88
32	96	1/8	6	234	60	25	141	85	25	23	44	100	155	56	88
40	120	1/8	8	258	60	45	167	97	26	36	64	100	160	68	100
50	150	1/4	8	284	60	45	198	108	36	36	64	100	170	85	117
63	150	1/4	8	320	60	45	216	126	36	36	64	100	170	85	117

d [mm]	H9 [mm]	H10 [mm]	Lift = Hx [mm]
20	14	12	8
25	18	12	10
32	21	12	12
40	26	15	14
50	33	15	18
63	39	15	22

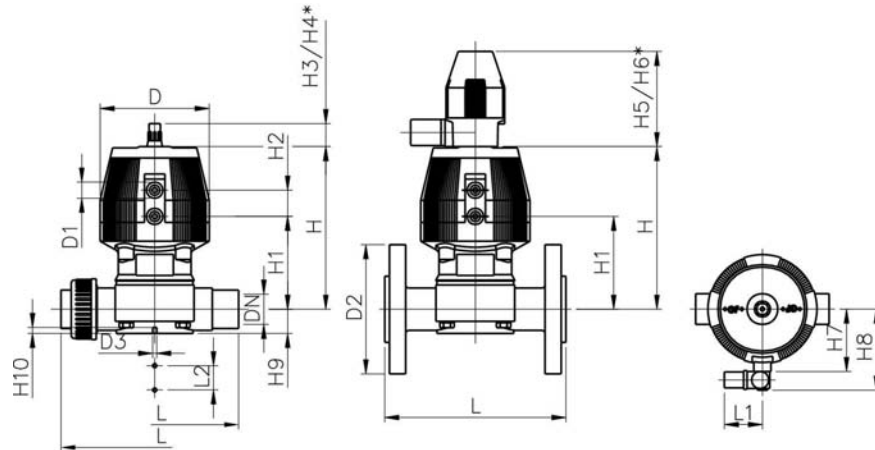

PF 3 39 212



SYGEF® standard
Diaphragm valve type DIASTAR 028
Function FC (Fail safe to close)
With fusion spigots metric

E

- With position indicator / Working pressure: **one side**

d [mm]	DN [mm]	PN	kv-value ($\Delta p=1$ bar) [l/min]	PTFE/EPDM Code	kg
20	15	5	72	199 028 321	0.520
25	20	7	120	199 028 322	0.950
32	25	7	238	199 028 323	1.370
40	32	7	341	199 028 324	1.810
50	40	7	460	199 028 325	3.350
63	50	7	685	199 028 326	6.270

d [mm]	D [mm]	D1_G [inch]	D3[M] [mm]	L [mm]	L1 [mm]	L2 [mm]	H [mm]	H1 [mm]	H2 [mm]	H3 [mm]	H4 [mm]	H5 [mm]	H6 [mm]	H7 [mm]	H8 [mm]
20	68	1/8	6	124	60	25	98	59	24	23	44	100	155	44	76
25	96	1/8	6	144	60	25	127	71	25	23	44	100	155	56	88
32	96	1/8	6	154	60	25	141	85	25	23	44	100	155	56	88
40	120	1/8	8	174	60	45	167	97	26	36	64	100	160	68	100
50	150	1/4	8	194	60	45	198	108	36	36	64	100	170	85	117
63	150	1/4	8	224	60	45	216	126	36	36	64	100	170	85	117

d [mm]	H9 [mm]	H10 [mm]	Lift = Hx [mm]
20	14	12	8
25	18	12	10
32	21	12	12
40	26	15	14
50	33	15	18
63	39	15	22

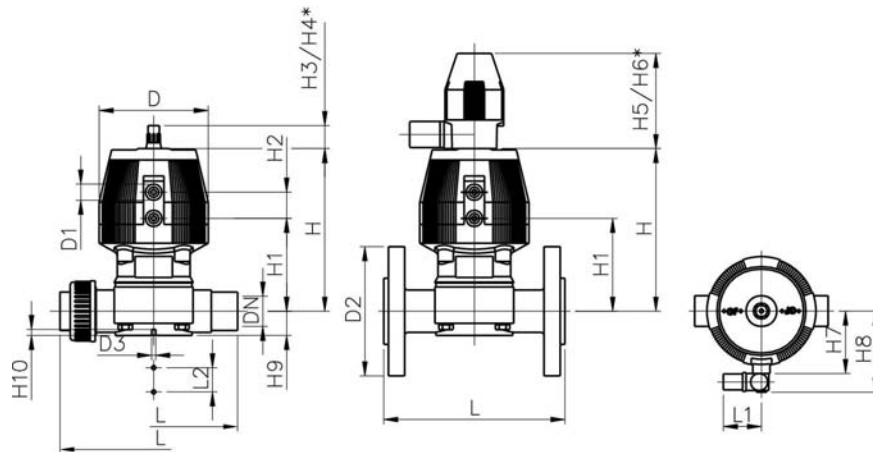

PF 3 39 212



SYGEF® standard
Diaphragm valve type DIASTAR 028
Function FC (Fail safe to close)
Unions with fusion sockets metric

E

- With position indicator / Working pressure: **one side**

d [mm]	DN [mm]	PN	kv-value ($\Delta p=1$ bar) [l/min]	PTFE/EPDM Code	kg
20	15	5	72	199 028 193	0.836
25	20	7	120	199 028 194	0.870
32	25	7	238	199 028 195	1.505
40	32	7	341	199 028 196	2.604
50	40	7	460	199 028 197	2.250
63	50	7	685	199 028 198	3.500

d [mm]	D [mm]	D1_G [inch]	D3[M] [mm]	L [mm]	L1 [mm]	L2 [mm]	H [mm]	H1 [mm]	H2 [mm]	H3 [mm]	H4 [mm]	H5 [mm]	H6 [mm]	H7 [mm]	H8 [mm]
20	68	1/8	6	128	60	25	98	59	24	23	44	100	155	44	76
25	96	1/8	6	150	60	25	127	71	25	23	44	100	155	56	88
32	96	1/8	6	162	60	25	141	85	25	23	44	100	155	56	88
40	120	1/8	8	184	60	45	167	97	26	36	64	100	160	68	100
50	150	1/4	8	210	60	45	198	108	36	36	64	100	170	85	117
63	150	1/4	8	248	60	45	216	126	36	36	64	100	170	85	117

d [mm]	H9 [mm]	H10 [mm]	Lift = Hx [mm]
20	14	12	8
25	18	12	10
32	21	12	12
40	26	15	14
50	33	15	18
63	39	15	22

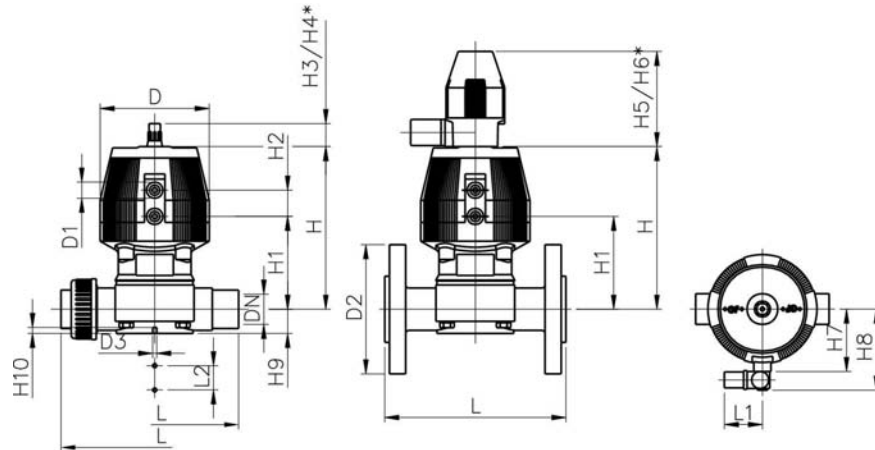

PF 3 39 212



SYGEF® standard
Diaphragm valve type DIASTAR 028
Function FC (Fail safe to close)
With backing flanges PP-V metric

E

Model:

- Connecting dimensions: ISO 7005 / EN 1092 / DIN 2501 PN10 / BS4504
- With position indicator / Working pressure: **one side**

d [mm]	DN [mm]	Inch	PN	kv-value ($\Delta p=1$ bar) [l/min]	PTFE/EPDM Code	kg
20	15	1/2	5	72	199 028 351	0.520
25	20	3/4	7	120	199 028 352	0.950
32	25	1	7	238	199 028 353	1.370
40	32	1 1/4	7	341	199 028 354	1.810
50	40	1 1/2	7	460	199 028 355	3.350
63	50	2	7	685	199 028 356	6.270

d [mm]	D [mm]	D1_G [inch]	D2 [mm]	D3[M] [mm]	L [mm]	L1 [mm]	L2 [mm]	H [mm]	H1 [mm]	H2 [mm]	H3 [mm]	H4 [mm]	H5 [mm]	H6 [mm]	H7 [mm]
20	68	1/8	95	6	130	60	25	98	59	24	23	44	100	155	44
25	96	1/8	105	6	150	60	25	127	71	25	23	44	100	155	56
32	96	1/8	115	6	160	60	25	141	85	25	23	44	100	155	56
40	120	1/8	140	8	180	60	45	167	97	26	36	64	100	160	68
50	150	1/4	150	8	200	60	45	198	108	36	36	64	100	170	85
63	150	1/4	165	8	230	60	45	216	126	36	36	64	100	170	85

d [mm]	H8 [mm]	H9 [mm]	H10 [mm]	Lift = Hx [mm]
20	76	14	12	8
25	88	18	12	10
32	88	21	12	12
40	100	26	15	14
50	117	33	15	18
63	117	39	15	22

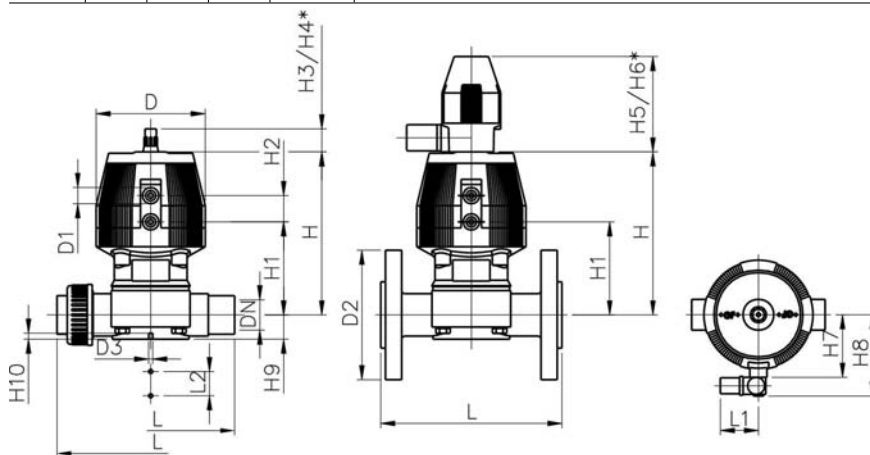

PF 3 39 212



SYGEF® standard
Diaphragm valve type DIASTAR 028
Function FC (Fail safe to close)
With backing flanges PP-V ANSI

E

Model:

- Overall length according to EN 558-1
- Connecting dimension: ANSI B 16.5 class 150 (ASTM D 4024), BS EN 1759

- With position indicator / Working pressure: **one side**

Inch	DN [mm]	PN	kv-value ($\Delta p=1$ bar) [l/min]	PTFE/EPDM Code	kg
1/2	15	5	72	199 028 361	1.370
3/4	20	7	120	199 028 362	
1	25	7	238	199 028 363	
1 1/4	32	7	341	199 028 364	3.350
1 1/2	40	7	460	199 028 365	
2	50	7	685	199 028 366	

Inch	D [mm]	D1_G [inch]	D2 [mm]	D3[M] [mm]	L [mm]	L1 [mm]	L2 [mm]	H [mm]	H1 [mm]	H2 [mm]	H3 [mm]	H4 [mm]	H5 [mm]	H6 [mm]
1/2	68	1/8	95	6	130	60	25	98	59	24	23	44	100	155
3/4	96	1/8	105	6	150	60	25	127	71	25	23	44	100	155
1	96	1/8	115	6	160	60	25	141	85	25	23	44	100	155
1 1/4	120	1/8	140	8	180	60	45	167	97	26	36	64	100	160
1 1/2	150	1/4	150	8	200	60	45	198	108	36	36	64	100	170
2	150	1/4	165	8	230	60	45	216	126	36	36	64	100	170

Inch	H7 [mm]	H8 [mm]	H9 [mm]	H10 [mm]	Lift = Hx [mm]
1/2	44	76	14	12	8
3/4	56	88	18	12	10
1	56	88	21	12	12
1 1/4	68	100	26	15	14
1 1/2	85	117	33	15	18
2	85	117	39	15	22

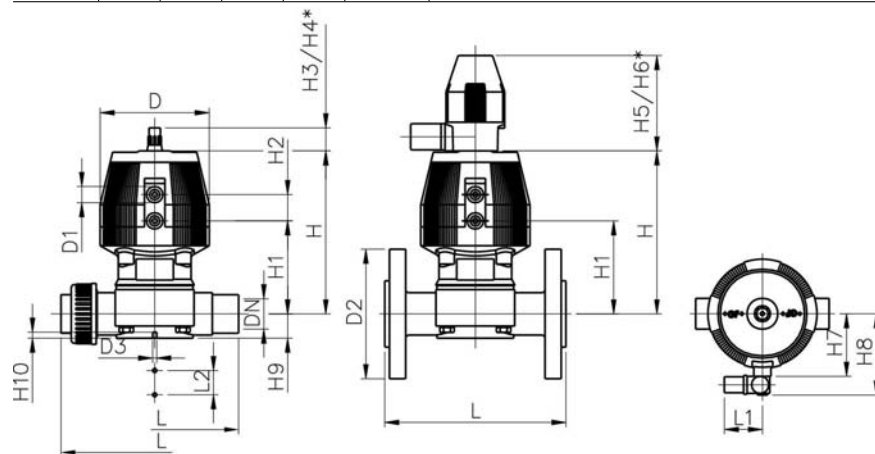

PF 3 39 212



SYGEF® standard
Diaphragm valve type DIASTAR 025
Function FC (Fail safe to close)
With butt fusion spigots IR metric

E

- With position indicator / Working pressure: both sides

d [mm]	DN [mm]	PN	kv-value ($\Delta p=1$ bar) [l/min]	PTFE/EPDM Code	kg
20	15	10	72	199 027 971	0.805
25	20	10	120	199 027 972	0.882
32	25	10	238	199 027 973	1.597
40	32	10	341	199 027 974	2.496
50	40	10	460	199 027 975	4.240
63	50	10	685	199 027 976	4.806

d [mm]	D [mm]	D1_G [inch]	D3[M] [mm]	L [mm]	L1 [mm]	L2 [mm]	H [mm]	H1 [mm]	H2 [mm]	H3 [mm]	H4 [mm]	H5 [mm]	H6 [mm]	H7 [mm]	H8 [mm]
20	96	1/8	6	124	60	25	125	69	25	23	44	100	155	56	86
25	96	1/8	6	144	60	25	127	71	25	23	44	100	155	56	88
32	120	1/8	6	154	60	25	163	93	26	36	64	100	155	68	100
40	150	1/4	8	174	60	45	196	106	36	36	64	100	160	85	117
50	180	1/4	8	194	60	45	227	119	37	36	64	100	170	101	133
63	180	1/4	8	224	60	45	241	133	37	36	64	100	170	101	133

d [mm]	H9 [mm]	H10 [mm]	Lift = Hx [mm]
20	14	12	8
25	18	12	10
32	21	12	12
40	26	15	14
50	33	15	18
63	39	15	22

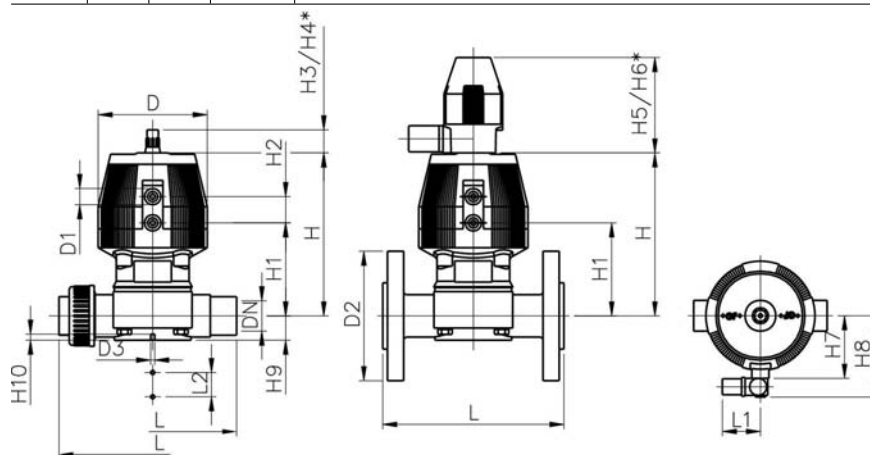

PF 3 39 212



SYGEF® standard
Diaphragm valve type DIASTAR 025
Function FC (Fail safe to close)
Unions with butt fusion spigots IR metric

E

- With position indicator / Working pressure: both sides

d [mm]	DN [mm]	PN	kv-value ($\Delta p=1$ bar) [l/min]	PTFE/EPDM Code	kg
20	15	10	72	199 027 491	0.836
25	20	10	120	199 027 492	0.836
32	25	10	238	199 027 493	1.505
40	32	10	341	199 027 494	2.604
50	40	10	460	199 027 495	2.604
63	50	10	685	199 027 496	2.604

d [mm]	D [mm]	D1_G [inch]	D3[M] [mm]	L [mm]	L1 [mm]	L2 [mm]	H [mm]	H1 [mm]	H2 [mm]	H3 [mm]	H4 [mm]	H5 [mm]	H6 [mm]	H7 [mm]	H8 [mm]
20	96	1/8	6	196	60	25	125	69	25	23	44	100	155	56	86
25	96	1/8	6	220	60	25	127	71	25	23	44	100	155	56	88
32	120	1/8	6	234	60	25	163	93	26	36	64	100	155	68	100
40	150	1/4	8	258	60	45	196	106	36	36	64	100	160	85	117
50	180	1/4	8	284	60	45	227	119	37	36	64	100	170	101	133
63	180	1/4	8	320	60	45	241	133	37	36	64	100	170	101	133

d [mm]	H9 [mm]	H10 [mm]	Lift = Hx [mm]
20	14	12	8
25	18	12	10
32	21	12	12
40	26	15	14
50	33	15	18
63	39	15	22

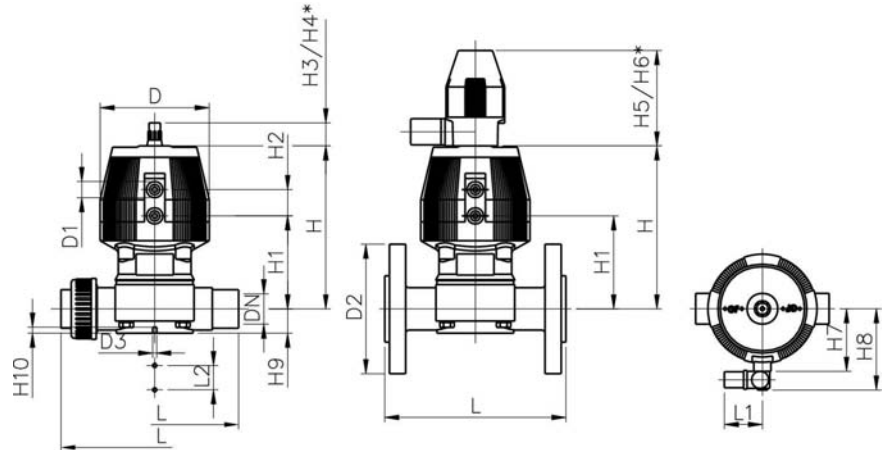

PF 3 39 212



SYGEF® standard
Diaphragm valve type DIASTAR 025
Function FC (Fail safe to close)
With fusion spigots metric

E

- With position indicator / Working pressure: both sides

d [mm]	DN [mm]	PN	kv-value ($\Delta p=1$ bar) [l/min]	PTFE/EPDM Code	kg
20	15	10	72	199 025 321	0.805
25	20	10	120	199 025 322	0.882
32	25	10	238	199 025 323	1.597
40	32	10	341	199 025 324	2.496
50	40	10	460	199 025 325	4.240
63	50	10	685	199 025 326	4.806

d [mm]	D [mm]	D1_G [inch]	D3[M] [mm]	L [mm]	L1 [mm]	L2 [mm]	H [mm]	H1 [mm]	H2 [mm]	H3 [mm]	H4 [mm]	H5 [mm]	H6 [mm]	H7 [mm]	H8 [mm]
20	96	1/8	6	124	60	25	125	69	25	23	44	100	155	56	86
25	96	1/8	6	144	60	25	127	71	25	23	44	100	155	56	88
32	120	1/8	6	154	60	25	163	93	26	36	64	100	155	68	100
40	150	1/4	8	174	60	45	196	106	36	36	64	100	160	85	117
50	180	1/4	8	194	60	45	227	119	37	36	64	100	170	101	133
63	180	1/4	8	224	60	45	241	133	37	36	64	100	170	101	133

d [mm]	H9 [mm]	H10 [mm]	Lift = Hx [mm]
20	14	12	8
25	18	12	10
32	21	12	12
40	26	15	14
50	33	15	18
63	39	15	22

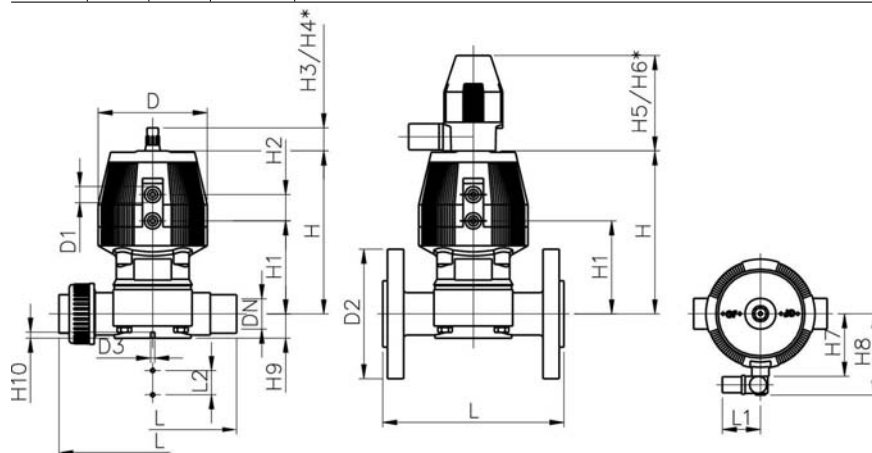

PF 3 39 212



SYGEF® standard
Diaphragm valve type DIASTAR 025
Function FC (Fail safe to close)
Unions with fusion sockets metric

E

- With position indicator / Working pressure: both sides

d [mm]	DN [mm]	PN	kv-value ($\Delta p=1$ bar) [l/min]	PTFE/EPDM Code	kg
20	15	10	72	199 027 321	0.836
25	20	10	120	199 027 322	0.836
32	25	10	238	199 027 323	2.400
40	32	10	341	199 027 324	3.500
50	40	10	460	199 027 325	2.604
63	50	10	685	199 027 326	2.604

d [mm]	D [mm]	D1_G [inch]	D3[M] [mm]	L [mm]	L1 [mm]	L2 [mm]	H [mm]	H1 [mm]	H2 [mm]	H3 [mm]	H4 [mm]	H5 [mm]	H6 [mm]	H7 [mm]	H8 [mm]
20	96	1/8	6	128	60	25	125	69	25	23	44	100	155	56	86
25	96	1/8	6	150	60	25	127	71	25	23	44	100	155	56	88
32	120	1/8	6	162	60	25	163	93	26	36	64	100	155	68	100
40	150	1/4	8	184	60	45	196	106	36	36	64	100	160	85	117
50	180	1/4	8	210	60	45	227	119	37	36	64	100	170	101	133
63	180	1/4	8	248	60	45	241	133	37	36	64	100	170	101	133

d [mm]	H9 [mm]	H10 [mm]	Lift = Hx [mm]
20	14	12	8
25	18	12	10
32	21	12	12
40	26	15	14
50	33	15	18
63	39	15	22

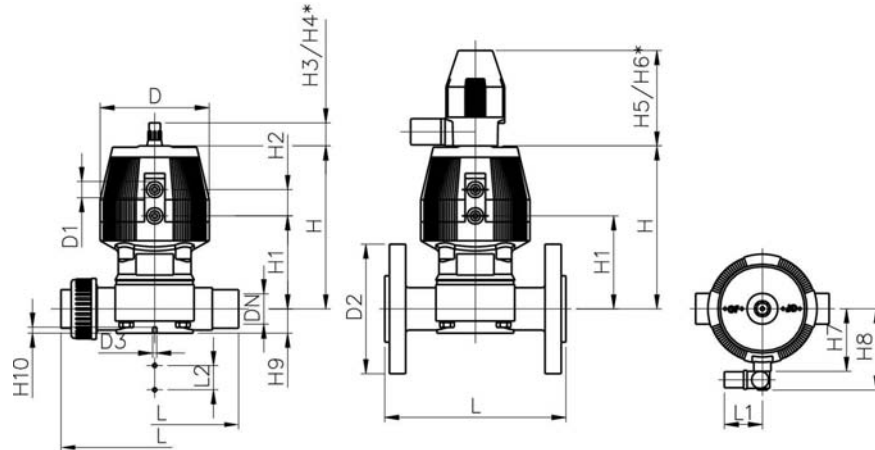

PF 3 39 212



SYGEF® standard
Diaphragm valve type DIASTAR 025
Function FC (Fail safe to close)
With backing flanges PP-V metric

E

Model:

- Connecting dimensions: ISO 7005 / EN 1092 / DIN 2501 PN10 / BS4504
- With position indicator / Working pressure: both sides

d [mm]	DN [mm]	Inch	PN	kv-value ($\Delta p=1$ bar) [l/min]	PTFE/EPDM Code	kg
20	15	1/2	10	72	199 025 351	0.839
25	20	3/4	10	120	199 025 352	0.936
32	25	1	10	238	199 025 353	2.700
40	32	1 1/4	10	341	199 025 354	3.800
50	40	1 1/2	10	460	199 025 355	4.665
63	50	2	10	685	199 025 356	5.353

d [mm]	D [mm]	D1_G [inch]	D3[M] [mm]	D2 [mm]	L [mm]	L1 [mm]	L2 [mm]	H [mm]	H1 [mm]	H2 [mm]	H3 [mm]	H4 [mm]	H5 [mm]	H6 [mm]	H7 [mm]
20	96	1/8	6	95	130	60	25	125	69	25	23	44	100	155	56
25	96	1/8	6	105	150	60	25	127	71	25	23	44	100	155	56
32	120	1/8	6	115	160	60	25	163	93	26	36	64	100	155	68
40	150	1/4	8	140	180	60	45	196	106	36	36	64	100	160	85
50	180	1/4	8	150	200	60	45	227	119	37	36	64	100	170	101
63	180	1/4	8	165	230	60	45	241	133	37	36	64	100	170	101

d [mm]	H8 [mm]	H9 [mm]	H10 [mm]	Lift = Hx [mm]
20	86	14	12	8
25	88	18	12	10
32	100	21	12	12
40	117	26	15	14
50	133	33	15	18
63	133	39	15	22

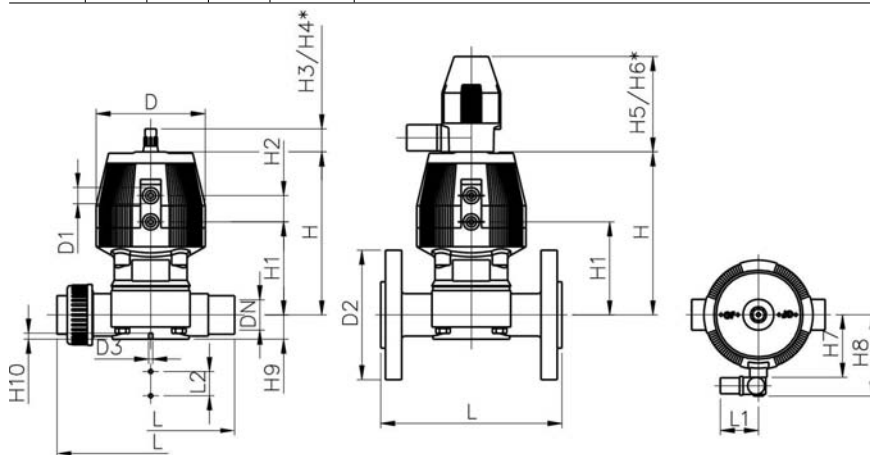

PF 3 39 212



SYGEF® standard
Diaphragm valve type DIASTAR 025
Function FC (Fail safe to close)
With fixed flanges PVDF metric

E

Model:

- Connecting dimensions: ISO 7005 / EN 1092 / DIN 2501 PN10 / BS4504
- With position indicator / Working pressure: on one side

* With backing flanges PP-V

** Connecting dimensions DN80 and DN150 metric and Inch ANSI B16.5

d [mm]	DN [mm]	Inch	PN	kv-value ($\Delta p=1$ bar) [l/min]	PTFE/EPDM Code	kg
*75	65	2 ½	10	992	199 025 357	13.600
**90	80	3	10	1700	199 025 358	17.400
110	100	4	8	2700	199 025 359	24.700

d [mm]	D [mm]	D1_G [inch]	D2 [mm]	D3[M] [mm]	D4 [mm]	L [mm]	L2 [mm]	H [mm]	H1 [mm]	H2 [mm]	H3 [mm]	H4 [mm]
*75	280	¼	185	8	145	290	70	344	148	24	46	100
**90	280	¼	200	12	160	310	120	348	150	24	46	100
110	335	¼	225	12	180	350	120	395	176	24	46	100

d [mm]	H5 [mm]	H6 [mm]	H7 [mm]	H9 [mm]	H10 [mm]
*75	129	195	298	46	15
**90	129	195	302	57	15
110	129	195	349	69	20

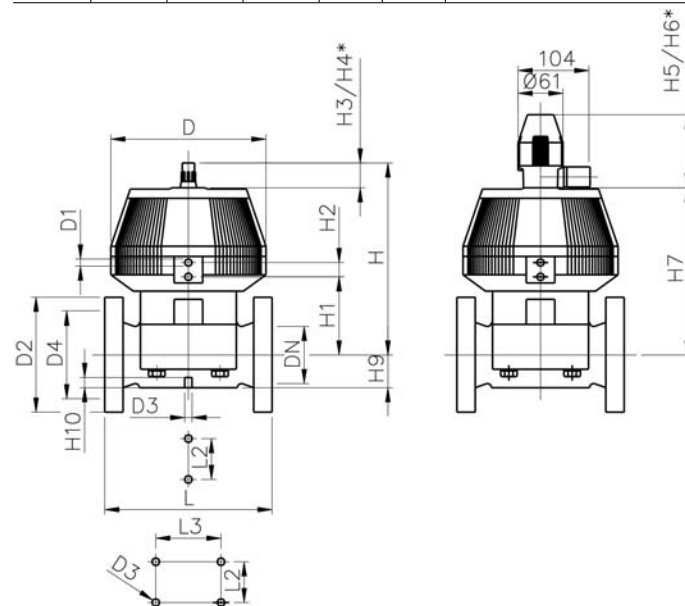

PF 3 39 212



SYGEF® standard
Diaphragm valve type DIASTAR 025
Function FC (Fail safe to close)
With backing flanges PP-V ANSI

E

Model:

- Overall length according to EN 558-1
- Connecting dimension: ANSI B 16.5 class 150 (ASTM D 4024), BS EN 1759
- With position indicator / Working pressure: both sides

Inch	DN [mm]	PN	kv-value ($\Delta p=1$ bar) [l/min]	PTFE/EPDM Code	kg
½	15	10	72	199 025 601	0.839
¾	20	10	120	199 025 602	0.936
1	25	10	238	199 025 603	1.705
1 ¼	32	10	341	199 025 604	2.904
1 ½	40	10	460	199 025 605	4.665
2	50	10	685	199 025 606	5.353

Inch	D [mm]	D1_G [inch]	D3[M] [mm]	D2 [mm]	L [mm]	L1 [mm]	L2 [mm]	H [mm]	H1 [mm]	H2 [mm]	H3 [mm]	H4 [mm]	H5 [mm]	H6 [mm]
½	96	⅝	6	95	130	60	25	125	69	25	23	44	100	155
¾	96	⅝	6	105	150	60	25	127	71	25	23	44	100	155
1	120	⅝	6	115	160	60	25	163	93	26	36	64	100	155
1 ¼	150	¾	8	140	180	60	45	196	106	36	36	64	100	160
1 ½	180	¾	8	150	200	60	45	227	119	37	36	64	100	170
2	180	¾	8	165	230	60	45	241	133	37	36	64	100	170

Inch	H7 [mm]	H8 [mm]	H9 [mm]	H10 [mm]	Lift = Hx [mm]
½	56	86	14	12	8
¾	56	88	18	12	10
1	68	100	21	12	12
1 ¼	85	117	26	15	14
1 ½	101	133	33	15	18
2	101	133	39	15	22

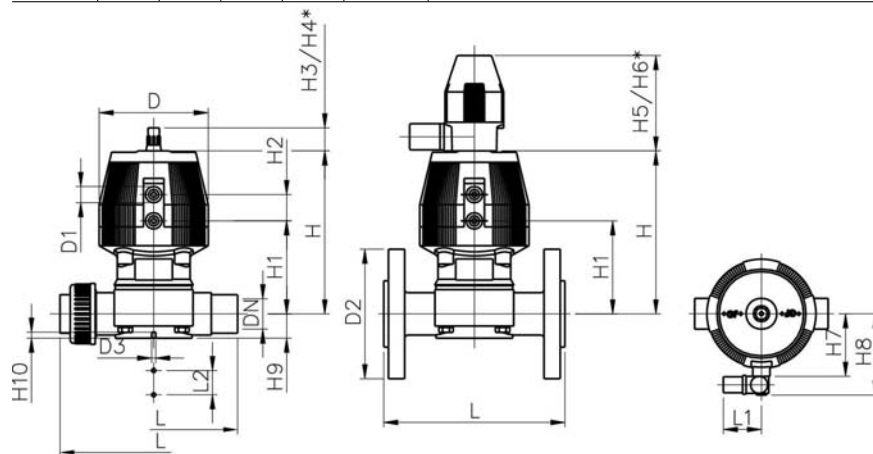

PF 3 39 212



SYGEF® standard
Diaphragm valve type DIASTAR 025
Function FC (Fail safe to close)
With fixed flanges PVDF ANSI

E

Model:

- Overall length according to EN 558-1
- Connecting dimension: ANSI B 16.5 class 150 (ASTM D 4024), BS EN 1759
- With position indicator / Working pressure: on one side

* With backing flanges PP-V

** Connecting dimensions DN80 and DN150 metric and Inch ANSI B16.5

Inch	DN [mm]	PN	kv-value ($\Delta p=1$ bar) [l/min]	PTFE/EPDM Code	kg
*2 ½	65	10	992	199 025 327	14.200
**3	80	10	1700	199 025 358	17.400
4	100	8	2700	199 025 329	26.500

Inch	D [mm]	D1_G [inch]	D2 [mm]	D3[M] [mm]	D4 [mm]	L [mm]	L2 [mm]	H [mm]	H1 [mm]	H2 [mm]	H3 [mm]	H4 [mm]
*2 ½	280	¼	185	8	145	290	70	344	148	24	46	100
**3	280	¼	200	12	160	310	120	348	150	24	46	100
4	335	¼	225	12	180	350	120	395	176	24	46	100

Inch	H5 [mm]	H6 [mm]	H7 [mm]	H9 [mm]	H10 [mm]
*2 ½	129	195	298	46	15
**3	129	195	302	57	15
4	129	195	349	69	20

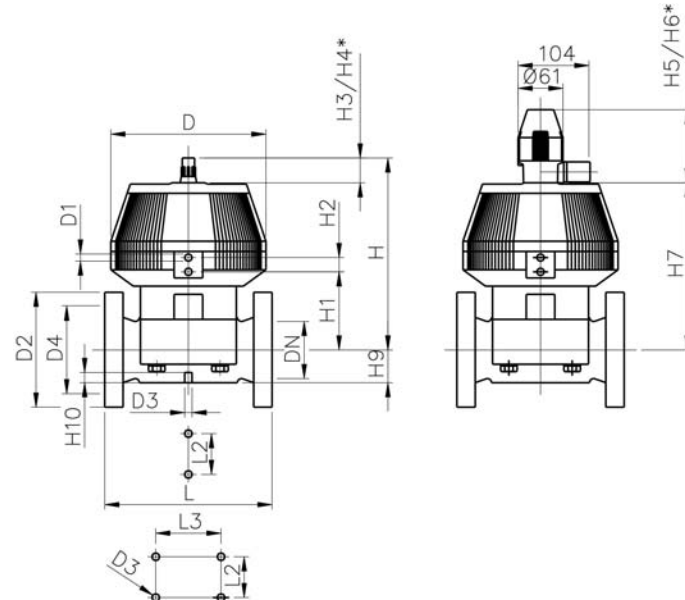

PF 3 39 212



SYGEF® standard
Diaphragm valve type DIASTAR 025
Function FO (Fail safe to open)
With butt fusion spigots IR metric

E

- With position indicator / Working pressure: both sides

d [mm]	DN [mm]	PN	kv-value ($\Delta p=1$ bar) [l/min]	PTFE/EPDM Code	kg
20	15	10	72	199 027 977	0.454
25	20	10	120	199 027 978	0.740
32	25	10	238	199 027 979	1.160
40	32	10	341	199 027 980	1.390
50	40	10	460	199 027 981	2.510
63	50	10	685	199 027 982	5.430

d [mm]	D [mm]	D1_G [inch]	D3[M] [mm]	L [mm]	L1 [mm]	L2 [mm]	H [mm]	H1 [mm]	H2 [mm]	H3 [mm]	H4 [mm]	H5 [mm]	H6 [mm]	H7 [mm]	H8 [mm]
20	68	1/8	6	124	60	25	98	59	24	23	44	100	155	44	76
25	96	1/8	6	144	60	25	127	71	25	23	44	100	155	56	88
32	96	1/8	6	154	60	25	141	85	25	23	44	100	155	56	88
40	120	1/8	8	174	60	45	167	97	26	36	64	100	160	68	100
50	150	1/4	8	194	60	45	198	108	36	36	64	100	170	85	117
63	150	1/4	8	224	60	45	216	126	36	36	64	100	170	85	117

d [mm]	H9 [mm]	H10 [mm]	Lift = Hx [mm]
20	14	12	8
25	18	12	10
32	21	12	12
40	26	15	14
50	33	15	18
63	39	15	22

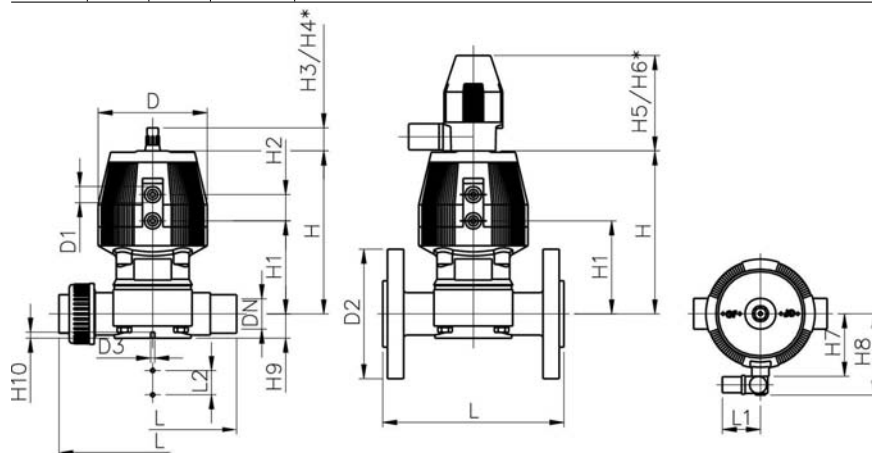

PF 3 39 212



SYGEF® standard
Diaphragm valve type DIASTAR 025
Function FO (Fail safe to open)
Unions with butt fusion spigots IR metric

E

- With position indicator / Working pressure: both sides

d [mm]	DN [mm]	PN	kv-value ($\Delta p=1$ bar) [l/min]	PTFE/EPDM Code	kg
20	15	10	72	199 027 501	0.836
25	20	10	120	199 027 502	0.836
32	25	10	238	199 027 503	0.624
40	32	10	341	199 027 504	2.604
50	40	10	460	199 027 505	4.165
63	50	10	685	199 027 506	4.553

d [mm]	D [mm]	D1_G [inch]	D3[M] [mm]	L [mm]	L1 [mm]	L2 [mm]	H [mm]	H1 [mm]	H2 [mm]	H3 [mm]	H4 [mm]	H5 [mm]	H6 [mm]	H7 [mm]	H8 [mm]
20	68	1/8	6	196	60	25	98	59	24	23	44	100	155	44	76
25	96	1/8	6	220	60	25	127	71	25	23	44	100	155	56	88
32	96	1/8	6	234	60	25	141	85	25	23	44	100	155	56	88
40	120	1/8	8	258	60	45	167	97	26	36	64	100	160	68	100
50	150	1/4	8	284	60	45	198	108	36	36	64	100	170	85	117
63	150	1/4	8	320	60	45	216	126	36	36	64	100	170	85	117

d [mm]	H9 [mm]	H10 [mm]	Lift = Hx [mm]
20	14	12	8
25	18	12	10
32	21	12	12
40	26	15	14
50	33	15	18
63	39	15	22

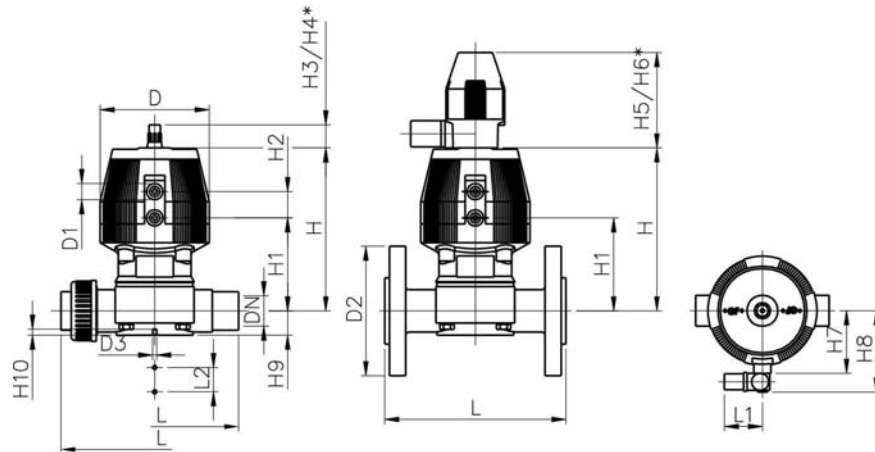

PF 3 39 212



SYGEF® standard
Diaphragm valve type DIASTAR 025
Function FO (Fail safe to open)
With fusion spigots metric

E

- With position indicator / Working pressure: both sides

d [mm]	DN [mm]	PN	kv-value ($\Delta p=1$ bar) [l/min]	PTFE/EPDM Code	kg
20	15	10	72	199 025 331	0.454
25	20	10	120	199 025 332	0.740
32	25	10	238	199 025 333	1.160
40	32	10	341	199 025 334	1.390
50	40	10	460	199 025 335	2.510
63	50	10	685	199 025 336	5.430

d [mm]	D [mm]	D1_G [inch]	D3[M] [mm]	L [mm]	L1 [mm]	L2 [mm]	H [mm]	H1 [mm]	H2 [mm]	H3 [mm]	H4 [mm]	H5 [mm]	H6 [mm]	H7 [mm]	H8 [mm]
20	68	1/8	6	124	60	25	98	59	24	23	44	100	155	44	76
25	96	1/8	6	144	60	25	127	71	25	23	44	100	155	56	88
32	96	1/8	6	154	60	25	141	85	25	23	44	100	155	56	88
40	120	1/8	8	174	60	45	167	97	26	36	64	100	160	68	100
50	150	1/4	8	194	60	45	198	108	36	36	64	100	170	85	117
63	150	1/4	8	224	60	45	216	126	36	36	64	100	170	85	117

d [mm]	H9 [mm]	H10 [mm]	Lift = Hx [mm]
20	14	12	8
25	18	12	10
32	21	12	12
40	26	15	14
50	33	15	18
63	39	15	22

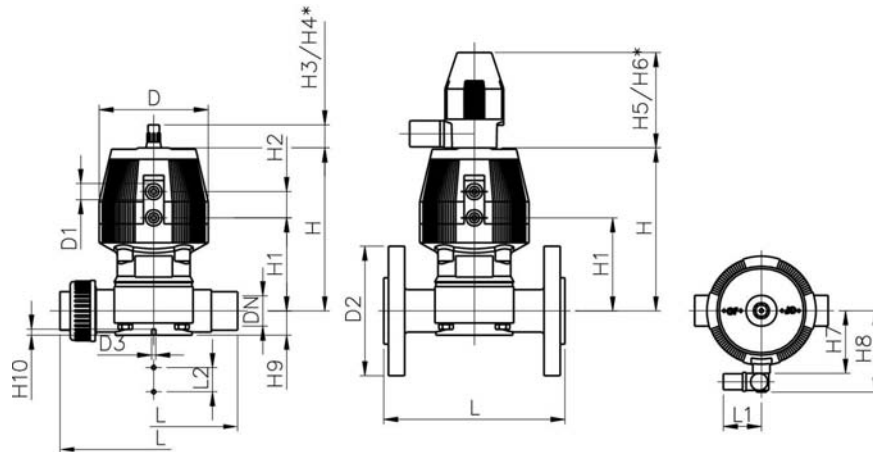

PF 3 39 212



SYGEF® standard
Diaphragm valve type DIASTAR 025
Function FO (Fail safe to open)
Unions with fusion sockets metric

E

- With position indicator / Working pressure: both sides

d [mm]	DN [mm]	PN	kv-value ($\Delta p=1$ bar) [l/min]	PTFE/EPDM Code	kg
20	15	10	72	199 027 331	0.624
25	20	10	120	199 027 332	0.950
32	25	10	238	199 027 333	1.360
40	32	10	341	199 027 334	1.580
50	40	10	460	199 027 335	2.910
63	50	10	685	199 027 336	5.310

d [mm]	D [mm]	D1_G [inch]	D3[M] [mm]	L [mm]	L1 [mm]	L2 [mm]	H [mm]	H1 [mm]	H2 [mm]	H3 [mm]	H4 [mm]	H5 [mm]	H6 [mm]	H7 [mm]	H8 [mm]
20	68	1/8	6	128	60	25	98	59	24	23	44	100	155	44	76
25	96	1/8	6	150	60	25	127	71	25	23	44	100	155	56	88
32	96	1/8	6	162	60	25	141	85	25	23	44	100	155	56	88
40	120	1/8	8	184	60	45	167	97	26	36	64	100	160	68	100
50	150	1/4	8	210	60	45	198	108	36	36	64	100	170	85	117
63	150	1/4	8	248	60	45	216	126	36	36	64	100	170	85	117

d [mm]	H9 [mm]	H10 [mm]	Lift = Hx [mm]
20	14	12	8
25	18	12	10
32	21	12	12
40	26	15	14
50	33	15	18
63	39	15	22

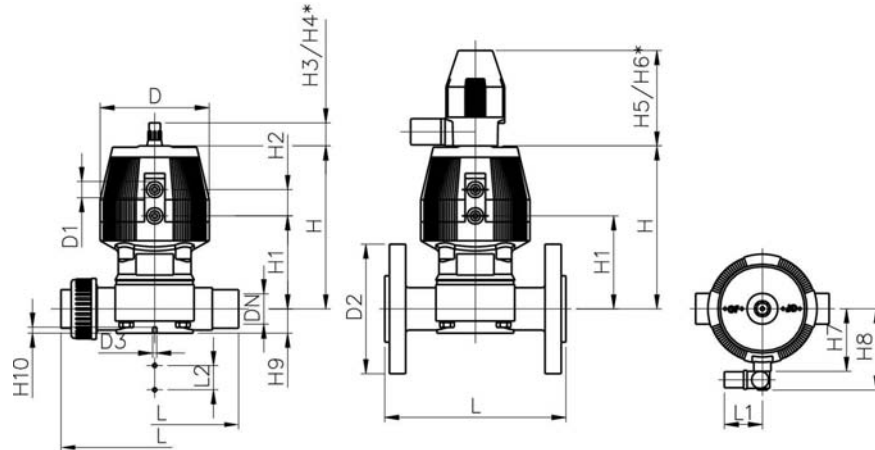

PF 3 39 212



SYGEF® standard
Diaphragm valve type DIASTAR 025
Function FO (Fail safe to open)
With backing flanges PP-V metric

E

Model:

- Connecting dimensions: ISO 7005 / EN 1092 / DIN 2501 PN10 / BS4504
- With position indicator / Working pressure: both sides

d [mm]	DN [mm]	Inch	PN	kv-value ($\Delta p=1$ bar) [l/min]	PTFE/EPDM Code	kg
20	15	1/2	10	72	199 025 361	0.824
25	20	3/4	10	120	199 025 362	1.090
32	25	1	10	238	199 025 363	1.610
40	32	1 1/4	10	341	199 025 364	1.950
50	40	1 1/2	10	460	199 025 365	3.010
63	50	2	10	685	199 025 366	5.510

d [mm]	D [mm]	D1_G [inch]	D2 [mm]	D3[M] [mm]	L [mm]	L1 [mm]	L2 [mm]	H [mm]	H1 [mm]	H2 [mm]	H3 [mm]	H4 [mm]	H5 [mm]	H6 [mm]	H7 [mm]
20	68	1/8	95	6	130	60	25	98	59	24	23	44	100	155	44
25	96	1/8	105	6	150	60	25	127	71	25	23	44	100	155	56
32	96	1/8	115	6	160	60	25	141	85	25	23	44	100	155	56
40	120	1/8	140	8	180	60	45	167	97	26	36	64	100	160	68
50	150	1/4	150	8	200	60	45	198	108	36	36	64	100	170	85
63	150	1/4	165	8	230	60	45	216	126	36	36	64	100	170	85

d [mm]	H8 [mm]	H9 [mm]	H10 [mm]	Lift = Hx [mm]
20	76	14	12	8
25	88	18	12	10
32	88	21	12	12
40	100	26	15	14
50	117	33	15	18
63	117	39	15	22

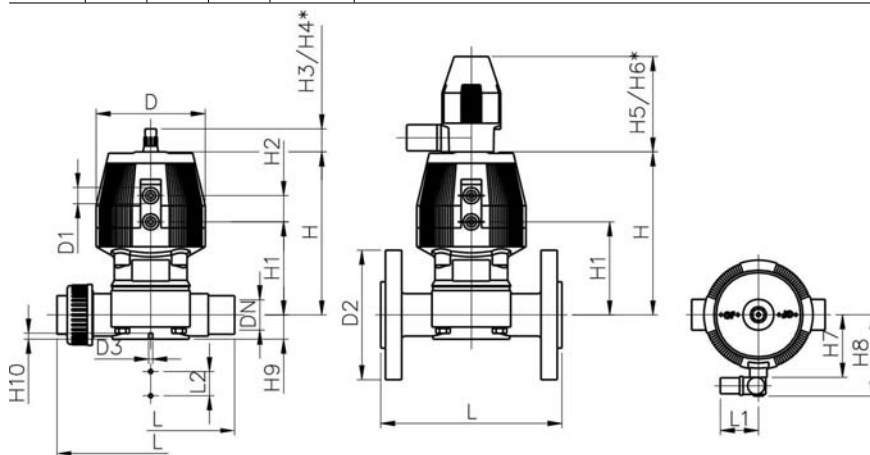

PF 3 39 212



SYGEF® standard
Diaphragm valve type DIASTAR 025
Function FO (Fail safe to open)
With fixed flanges PVDF metric

E

Model:

- Connecting dimensions: ISO 7005 / EN 1092 / DIN 2501 PN10 / BS4504
- With position indicator / Working pressure: on one side

* With backing flanges PP-V

** Connecting dimensions DN80 and DN150 metric and Inch ANSI B16.5

d [mm]	DN [mm]	Inch	PN	kv-value ($\Delta p=1$ bar) [l/min]	PTFE/EPDM Code	kg
*75	65	2 ½	10	992	199 025 367	13.600
**90	80	3	10	1700	199 025 368	17.400
110	100	4	8	2700	199 025 369	24.700
**160	150	6	6	6033	199 025 370	35.000

d [mm]	D [mm]	D1_G [inch]	D2 [mm]	D3[M] [mm]	D4 [mm]	L [mm]	L2 [mm]	L3 [mm]	H [mm]	H1 [mm]	H2 [mm]	H3 [mm]
*75	280	¼	185	8	145	290	70		344	148	24	46
**90	280	¼	200	12	160	310	120		348	150	24	46
110	335	¼	225	12	180	350	120		395	176	24	46
**160	335	¼	285	12	240	480	100	200	455	237	24	46

d [mm]	H4 [mm]	H5 [mm]	H6 [mm]	H7 [mm]	H9 [mm]	H10 [mm]
*75	100	129	195	298	46	15
**90	100	129	195	302	57	15
110	100	129	195	349	69	20
**160	100	129	195	409	108	20

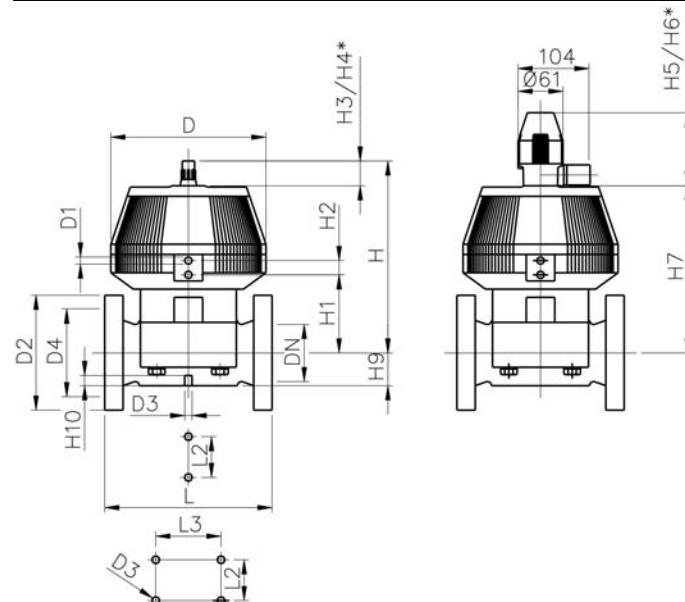

PF 3 39 212



SYGEF® standard
Diaphragm valve type DIASTAR 025
Function FO (Fail safe to open)
With backing flanges PP-V ANSI

E

Model:

- Overall length according to EN 558-1
- Connecting dimension: ANSI B 16.5 class 150 (ASTM D 4024), BS EN 1759
- With position indicator / Working pressure: both sides

Inch	DN [mm]	PN	kv-value ($\Delta p=1$ bar) [l/min]	PTFE/EPDM Code	kg
½	15	10	72	199 025 611	0.824
¾	20	10	120	199 025 612	1.090
1	25	10	238	199 025 613	1.610
1 ¼	32	10	341	199 025 614	1.950
1 ½	40	10	460	199 025 615	3.010
2	50	10	685	199 025 616	5.510

Inch	D [mm]	D1_G [inch]	D2 [mm]	D3[M] [mm]	L [mm]	L1 [mm]	L2 [mm]	H [mm]	H1 [mm]	H2 [mm]	H3 [mm]	H4 [mm]	H5 [mm]	H6 [mm]
½	68	⅝	95	6	130	60	25	98	59	24	23	44	100	155
¾	96	⅝	105	6	150	60	25	127	71	25	23	44	100	155
1	96	⅝	115	6	160	60	25	141	85	25	23	44	100	155
1 ¼	120	⅝	140	8	180	60	45	167	97	26	36	64	100	160
1 ½	150	¾	150	8	200	60	45	198	108	36	36	64	100	170
2	150	¾	165	8	230	60	45	216	126	36	36	64	100	170

Inch	H7 [mm]	H8 [mm]	H9 [mm]	H10 [mm]	Lift = Hx [mm]
½	44	76	14	12	8
¾	56	88	18	12	10
1	56	88	21	12	12
1 ¼	68	100	26	15	14
1 ½	85	117	33	15	18
2	85	117	39	15	22

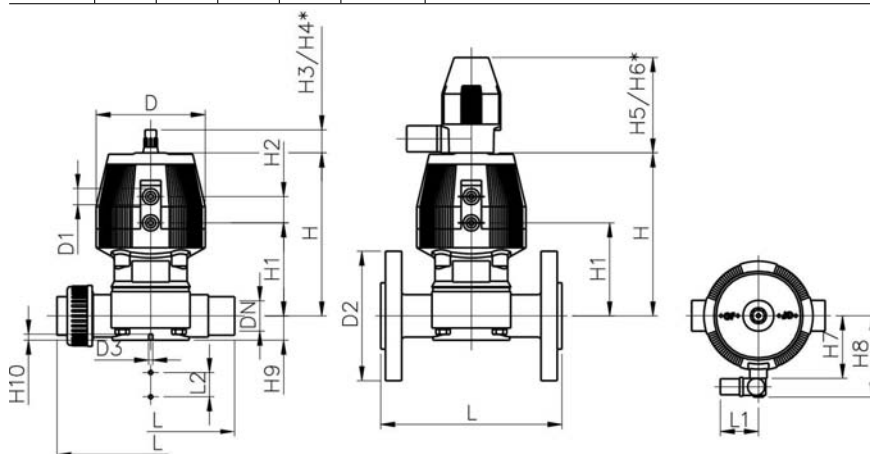

PF 3 39 212



SYGEF® standard
Diaphragm valve type DIASTAR 025
Function FO (Fail safe to open)
With fixed flanges PVDF ANSI

E

Model:

- Overall length according to EN 558-1
- Connecting dimension: ANSI B 16.5 class 150 (ASTM D 4024), BS EN 1759

- With position indicator / Working pressure: on one side

* With backing flanges PP-V

** Connecting dimensions DN80 and DN150 metric and Inch ANSI B16.5

Inch	DN [mm]	PN	kv-value ($\Delta p=1$ bar) [l/min]	PTFE/EPDM Code	kg
*2 1/2	65	10	992	199 025 337	12.200
**3	80	10	1700	199 025 368	17.400
4	100	8	2700	199 025 339	23.400
**6	150	6	6033	199 025 370	35.000

Inch	D [mm]	D1_G [inch]	D2 [mm]	D3[M] [mm]	D4 [mm]	L [mm]	L2 [mm]	L3 [mm]	H [mm]	H1 [mm]	H2 [mm]	H3 [mm]
*2 1/2	280	1/4	185	8	145	290	70		344	148	24	46
**3	280	1/4	200	12	160	310	120		348	150	24	46
4	335	1/4	225	12	180	350	120		395	176	24	46
**6	335	1/4	285	12	240	480	100	200	455	237	24	46

Inch	H4 [mm]	H5 [mm]	H6 [mm]	H7 [mm]	H9 [mm]	H10 [mm]
*2 1/2	100	129	195	298	46	15
**3	100	129	195	302	57	15
4	100	129	195	349	69	20
**6	100	129	195	409	108	20

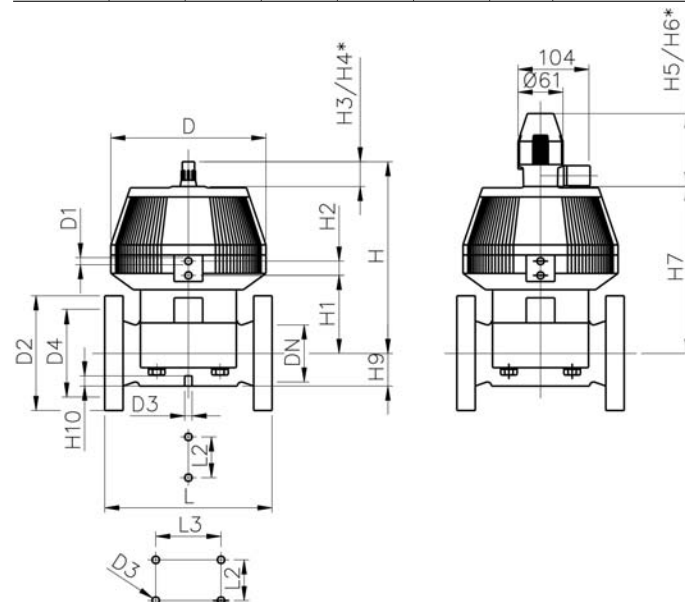

PF 3 39 212



SYGEF® standard
Diaphragm valve type DIASTAR 025
Function DA (Double acting)
With butt fusion spigots IR metric

E

- With position indicator / Working pressure: both sides

d [mm]	DN [mm]	PN	kv-value ($\Delta p=1$ bar) [l/min]	PTFE/EPDM Code	kg
20	15	10	72	199 027 983	0.454
25	20	10	120	199 027 984	0.740
32	25	10	238	199 027 985	1.160
40	32	10	341	199 027 986	1.390
50	40	10	460	199 027 987	2.510
63	50	10	685	199 027 988	5.430

d [mm]	D [mm]	D1_G [inch]	D3[M] [mm]	L [mm]	L1 [mm]	L2 [mm]	H [mm]	H1 [mm]	H2 [mm]	H3 [mm]	H4 [mm]	H5 [mm]	H6 [mm]	H7 [mm]	H8 [mm]
20	68	1/8	6	124	60	25	98	59	24	23	44	100	155	44	76
25	96	1/8	6	144	60	25	127	71	25	23	44	100	155	56	88
32	96	1/8	6	154	60	25	141	85	25	23	44	100	155	56	88
40	120	1/8	8	174	60	45	167	97	26	36	64	100	160	68	100
50	150	1/4	8	194	60	45	198	108	36	36	64	100	170	85	117
63	150	1/4	8	224	60	45	216	126	36	36	64	100	170	85	117

d [mm]	H9 [mm]	H10 [mm]	Lift = Hx [mm]
20	14	12	8
25	18	12	10
32	21	12	12
40	26	15	14
50	33	15	18
63	39	15	22

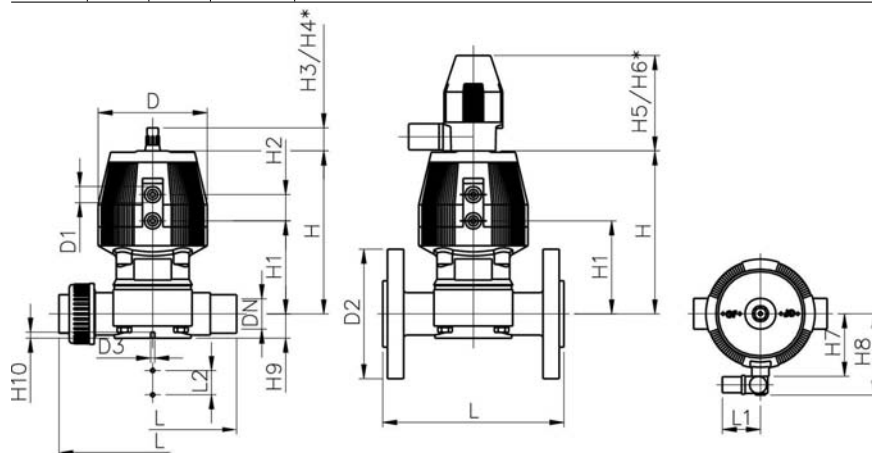

PF 3 39 212



SYGEF® standard
Diaphragm valve type DIASTAR 025
Function DA (Double acting)
Unions with butt fusion spigots IR metric

E

- With position indicator / Working pressure: both sides

d [mm]	DN [mm]	PN	kv-value ($\Delta p=1$ bar) [l/min]	PTFE/EPDM Code	kg
20	15	10	72	199 027 511	0.836
25	20	10	120	199 027 512	0.836
32	25	10	238	199 027 513	1.505
40	32	10	341	199 027 514	2.604
50	40	10	460	199 027 515	4.165
63	50	10	685	199 027 516	4.553

d [mm]	D [mm]	D1_G [inch]	D3[M] [mm]	L [mm]	L1 [mm]	L2 [mm]	H [mm]	H1 [mm]	H2 [mm]	H3 [mm]	H4 [mm]	H5 [mm]	H6 [mm]	H7 [mm]	H8 [mm]
20	68	1/8	6	196	60	25	98	59	24	23	44	100	155	44	76
25	96	1/8	6	220	60	25	127	71	25	23	44	100	155	56	88
32	96	1/8	6	234	60	25	141	85	25	23	44	100	155	56	88
40	120	1/8	8	258	60	45	167	97	26	36	64	100	160	68	100
50	150	1/4	8	284	60	45	198	108	36	36	64	100	170	85	117
63	150	1/4	8	320	60	45	216	126	36	36	64	100	170	85	117

d [mm]	H9 [mm]	H10 [mm]	Lift = Hx [mm]
20	14	12	8
25	18	12	10
32	21	12	12
40	26	15	14
50	33	15	18
63	39	15	22

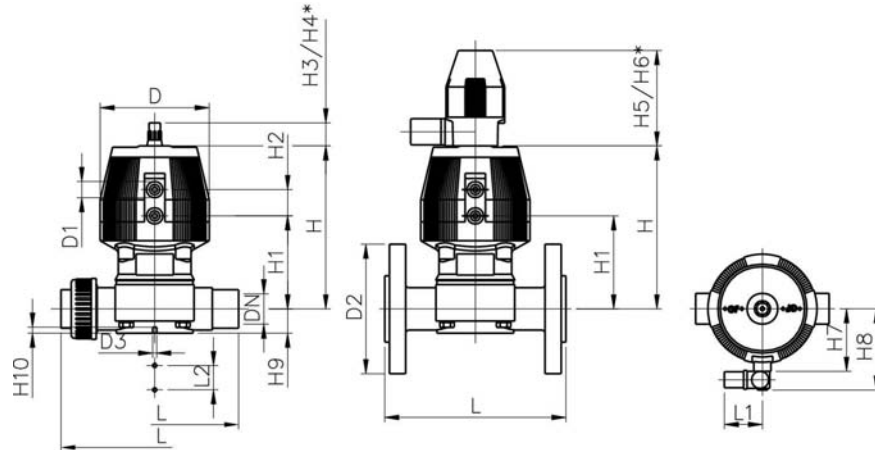

PF 3 39 212



SYGEF® standard
Diaphragm valve type DIASTAR 025
Function DA (Double acting)
With fusion spigots metric

E

- With position indicator / Working pressure: both sides

d [mm]	DN [mm]	PN	kv-value ($\Delta p=1$ bar) [l/min]	PTFE/EPDM Code	kg
20	15	10	72	199 025 341	0.454
25	20	10	120	199 025 342	0.740
32	25	10	238	199 025 343	1.160
40	32	10	341	199 025 344	1.390
50	40	10	460	199 025 345	2.510
63	50	10	685	199 025 346	5.430

d [mm]	D [mm]	D1_G [inch]	D3[M] [mm]	L [mm]	L1 [mm]	L2 [mm]	H [mm]	H1 [mm]	H2 [mm]	H3 [mm]	H4 [mm]	H5 [mm]	H6 [mm]	H7 [mm]	H8 [mm]
20	68	1/8	6	124	60	25	98	59	24	23	44	100	155	44	76
25	96	1/8	6	144	60	25	127	71	25	23	44	100	155	56	88
32	96	1/8	6	154	60	25	141	85	25	23	44	100	155	56	88
40	120	1/8	8	174	60	45	167	97	26	36	64	100	160	68	100
50	150	1/4	8	194	60	45	198	108	36	36	64	100	170	85	117
63	150	1/4	8	224	60	45	216	126	36	36	64	100	170	85	117

d [mm]	H9 [mm]	H10 [mm]	Lift = Hx [mm]
20	14	12	8
25	18	12	10
32	21	12	12
40	26	15	14
50	33	15	18
63	39	15	22

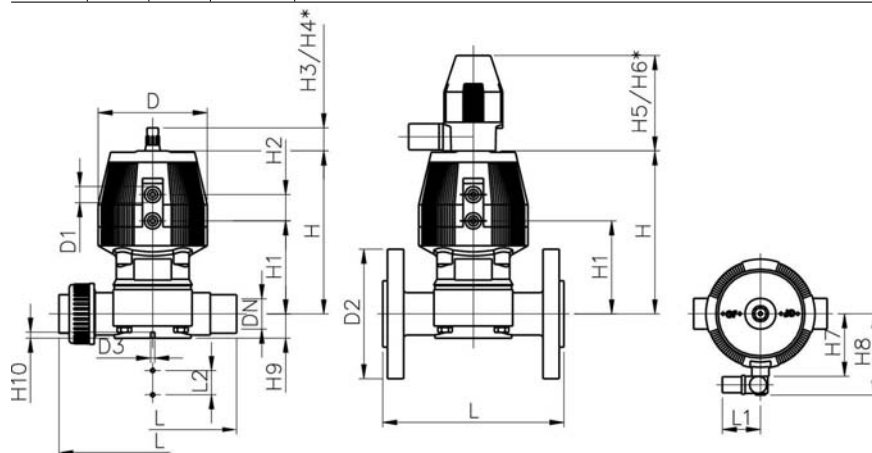

PF 3 39 212



SYGEF® standard
Diaphragm valve type DIASTAR 025
Function DA (Double acting)
Unions with fusion sockets metric

E

- With position indicator / Working pressure: both sides

d [mm]	DN [mm]	PN	kv-value ($\Delta p=1$ bar) [l/min]	PTFE/EPDM Code	kg
20	15	10	72	199 027 341	0.624
25	20	10	120	199 027 342	0.950
32	25	10	238	199 027 343	1.360
40	32	10	341	199 027 344	1.580
50	40	10	460	199 027 345	2.910
63	50	10	685	199 027 346	5.310

d [mm]	D [mm]	D1_G [inch]	D3[M] [mm]	L [mm]	L1 [mm]	L2 [mm]	H [mm]	H1 [mm]	H2 [mm]	H3 [mm]	H4 [mm]	H5 [mm]	H6 [mm]	H7 [mm]	H8 [mm]
20	68	1/8	6	128	60	25	98	59	24	23	44	100	155	44	76
25	96	1/8	6	150	60	25	127	71	25	23	44	100	155	56	88
32	96	1/8	6	162	60	25	141	85	25	23	44	100	155	56	88
40	120	1/8	8	184	60	45	167	97	26	36	64	100	160	68	100
50	150	1/4	8	210	60	45	198	108	36	36	64	100	170	85	117
63	150	1/4	8	248	60	45	216	126	36	36	64	100	170	85	117

d [mm]	H9 [mm]	H10 [mm]	Lift = Hx [mm]
20	14	12	8
25	18	12	10
32	21	12	12
40	26	15	14
50	33	15	18
63	39	15	22

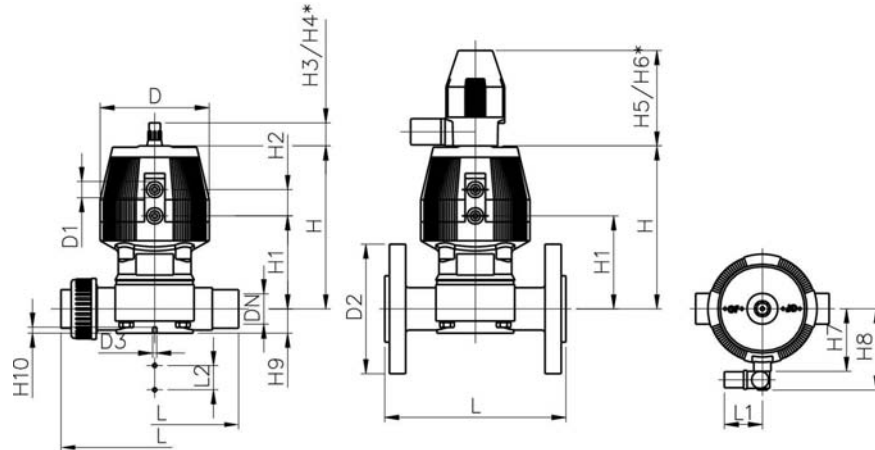

PF 3 39 212



SYGEF® standard
Diaphragm valve type DIASTAR 025
Function DA (Double acting)
With backing flanges PP-V metric

E

Model:

- Connecting dimensions: ISO 7005 / EN 1092 / DIN 2501 PN10 / BS4504
- With position indicator / Working pressure: both sides

d [mm]	DN [mm]	Inch	PN	kv-value ($\Delta p=1$ bar) [l/min]	PTFE/EPDM Code	kg
20	15	1/2	10	72	199 025 371	0.824
25	20	3/4	10	120	199 025 372	1.090
32	25	1	10	238	199 025 373	1.610
40	32	1 1/4	10	341	199 025 374	1.950
50	40	1 1/2	10	460	199 025 375	3.010
63	50	2	10	685	199 025 376	5.510

d [mm]	D [mm]	D1_G [inch]	D2 [mm]	D3[M] [mm]	L [mm]	L1 [mm]	L2 [mm]	H [mm]	H1 [mm]	H2 [mm]	H3 [mm]	H4 [mm]	H5 [mm]	H6 [mm]	H7 [mm]
20	68	1/8	95	6	130	60	25	98	59	24	23	44	100	155	44
25	96	1/8	105	6	150	60	25	127	71	25	23	44	100	155	56
32	96	1/8	115	6	160	60	25	141	85	25	23	44	100	155	56
40	120	1/8	140	8	180	60	45	167	97	26	36	64	100	160	68
50	150	1/4	150	8	200	60	45	198	108	36	36	64	100	170	85
63	150	1/4	165	8	230	60	45	216	126	36	36	64	100	170	85

d [mm]	H8 [mm]	H9 [mm]	H10 [mm]	Lift = Hx [mm]
20	76	14	12	8
25	88	18	12	10
32	88	21	12	12
40	100	26	15	14
50	117	33	15	18
63	117	39	15	22

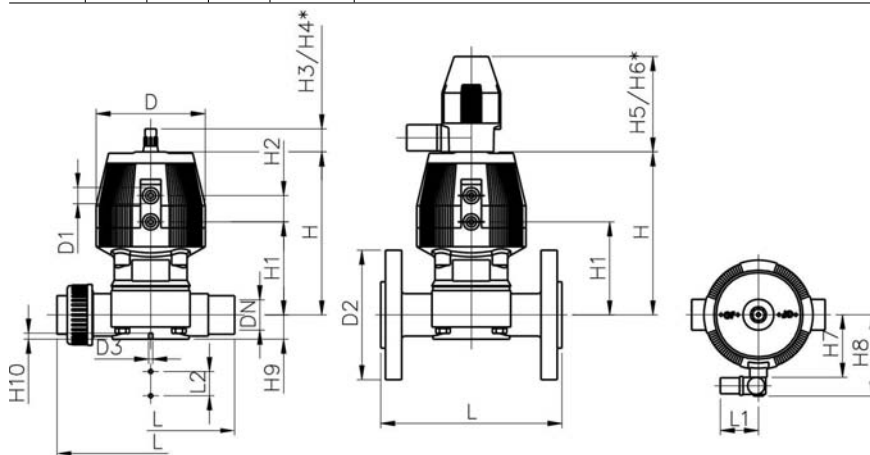

PF 3 39 212



SYGEF® standard
Diaphragm valve type DIASTAR 025
Function DA (Double acting)
With fixed flanges PVDF metric

E

Model:

- Connecting dimensions: ISO 7005 / EN 1092 / DIN 2501 PN10 / BS4504
- With position indicator / Working pressure: on one side

* With backing flanges PP-V

** Connecting dimensions DN80 and DN150 metric and Inch ANSI B16.5

d [mm]	DN [mm]	Inch	PN	kv-value ($\Delta p=1$ bar) [l/min]	PTFE/EPDM Code	kg
*75	65	2 ½	10	992	199 025 377	13.600
**90	80	3	10	1700	199 025 378	17.400
110	100	4	8	2700	199 025 379	24.700
**160	150	6	6	6033	199 025 380	35.000

d [mm]	D [mm]	D1_G [inch]	D2 [mm]	D3[M] [mm]	D4 [mm]	L [mm]	L2 [mm]	L3 [mm]	H [mm]	H1 [mm]	H2 [mm]	H3 [mm]
*75	280	¼	185	8	145	290	70		344	148	24	46
**90	280	¼	200	12	160	310	120		348	150	24	46
110	335	¼	225	12	180	350	120		395	176	24	46
**160	335	¼	285	12	240	480	100	200	455	237	24	46

d [mm]	H4 [mm]	H5 [mm]	H6 [mm]	H7 [mm]	H9 [mm]	H10 [mm]
*75	100	129	195	298	46	15
**90	100	129	195	302	57	15
110	100	129	195	349	69	20
**160	100	129	195	409	108	20

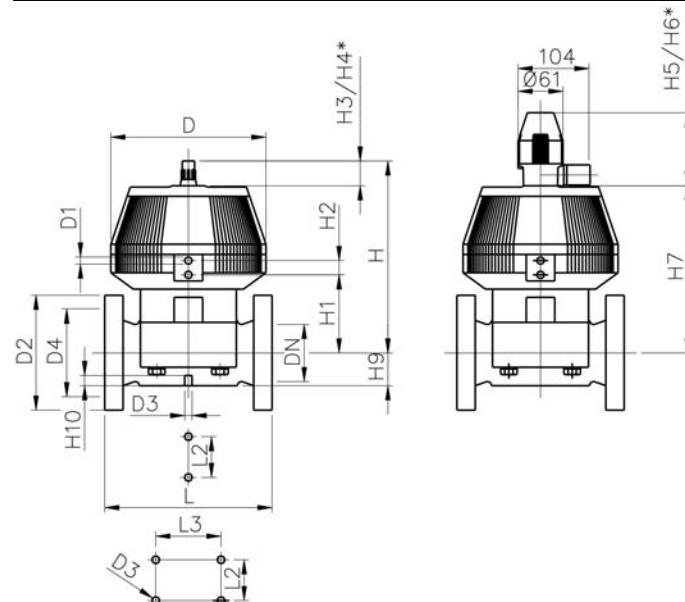

PF 3 39 212



SYGEF® standard
Diaphragm valve type DIASTAR 025
Function DA (Double acting)
With backing flanges PP-V ANSI

E

Model:

- Overall length according to EN 558-1
- Connecting dimension: ANSI B 16.5 class 150 (ASTM D 4024), BS EN 1759
- With position indicator / Working pressure: both sides

Inch	DN [mm]	PN	kv-value ($\Delta p=1$ bar) [l/min]	PTFE/EPDM Code	kg
½	15	10	72	199 025 621	0.824
¾	20	10	120	199 025 622	1.090
1	25	10	238	199 025 623	1.610
1 ¼	32	10	341	199 025 624	1.950
1 ½	40	10	460	199 025 625	3.010
2	50	10	685	199 025 626	5.510

Inch	D [mm]	D1_G [inch]	D2 [mm]	D3[M] [mm]	L [mm]	L1 [mm]	L2 [mm]	H [mm]	H1 [mm]	H2 [mm]	H3 [mm]	H4 [mm]	H5 [mm]	H6 [mm]
½	68	⅝	95	6	130	60	25	98	59	24	23	44	100	155
¾	96	⅝	105	6	150	60	25	127	71	25	23	44	100	155
1	96	⅝	115	6	160	60	25	141	85	25	23	44	100	155
1 ¼	120	⅝	140	8	180	60	45	167	97	26	36	64	100	160
1 ½	150	¼	150	8	200	60	45	198	108	36	36	64	100	170
2	150	¼	165	8	230	60	45	216	126	36	36	64	100	170

Inch	H7 [mm]	H8 [mm]	H9 [mm]	H10 [mm]	Lift = Hx [mm]
½	44	76	14	12	8
¾	56	88	18	12	10
1	56	88	21	12	12
1 ¼	68	100	26	15	14
1 ½	85	117	33	15	18
2	85	117	39	15	22

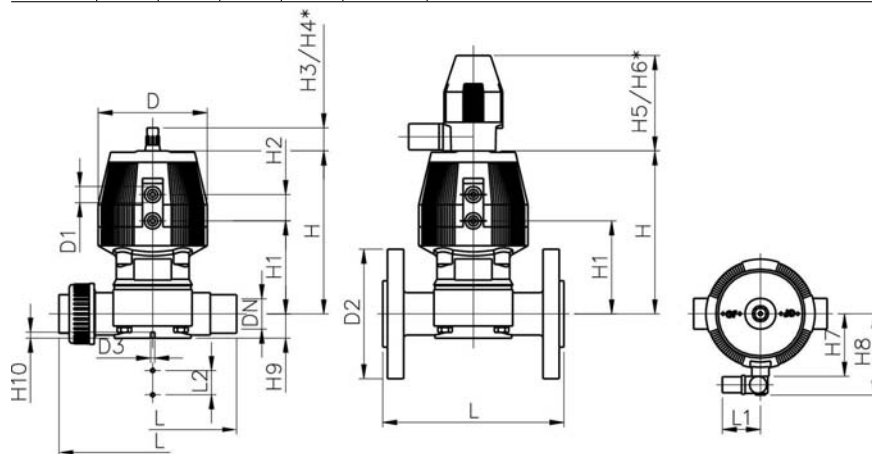

PF 3 39 212



SYGEF® standard
Diaphragm valve type DIASTAR 025
Function DA (Double acting)
With fixed flanges PVDF ANSI

E

Model:

- Overall length according to EN 558-1
- Connecting dimension: ANSI B 16.5 class 150 (ASTM D 4024), BS EN 1759

- With position indicator / Working pressure: on one side

* With backing flanges PP-V

** Connecting dimensions DN80 and DN150 metric and Inch ANSI B16.5

Inch	DN [mm]	PN	kv-value ($\Delta p=1$ bar) [l/min]	PTFE/EPDM Code	kg
*2 ½	65	10	992	199 025 347	13.000
**3	80	10	1700	199 025 378	17.400
4	100	8	2700	199 025 349	24.100
**6	150	6	6033	199 025 380	35.000

Inch	D [mm]	D1_G [inch]	D2 [mm]	D3[M] [mm]	D4 [mm]	L [mm]	L2 [mm]	L3 [mm]	H [mm]	H1 [mm]	H2 [mm]	H3 [mm]
*2 ½	280	¼	185	8	145	290	70		344	148	24	46
**3	280	¼	200	12	160	310	120		348	150	24	46
4	335	¼	225	12	180	350	120		395	176	24	46
**6	335	¼	285	12	240	480	100	200	455	237	24	46

Inch	H4 [mm]	H5 [mm]	H6 [mm]	H7 [mm]	H9 [mm]	H10 [mm]
*2 ½	100	129	195	298	46	15
**3	100	129	195	302	57	15
4	100	129	195	349	69	20
**6	100	129	195	409	108	20

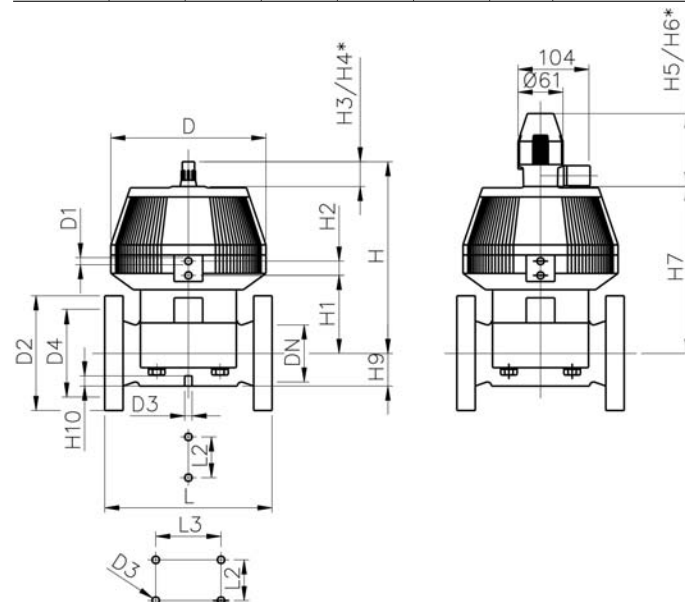

PF 3 39 212

Butterfly valves electric

SYGEF® standard Butterfly valve type 140 100-230V Without manual override

E



Model:

- Connecting dimension: ISO 7005 PN 10, EN 1092 PN 10, DIN 2501 PN 10, ANSI B 16.5 Class 150, BS 1560: 1989, BS 4504, JIS B 2220
- Overall length according to EN 558-1, ISO 5752
- Voltage 100-230 V, 50-60 Hz
- Control time 15 s/90°<) EA31
- Control time 25s/90°<) EA42
- Control range 90°<)
- Actuator with integrated emergency manual override standard

d [mm]	DN [mm]	Inch	PN	kv-value ($\Delta p=1$ bar) [l/min]	FPM Code	kg
63	50	2	10	1470	199 140 582	4.218
75	65	2 ½	10	2200	199 140 583	4.330
90	80	3	10	3000	199 140 584	4.510
110	100	4	10	6500	199 140 585	5.162
140	125	5	10	11500	199 140 586	5.757
160	150	6	10	16600	199 140 587	6.977
225	200	8	10	39600	199 140 588	13.638

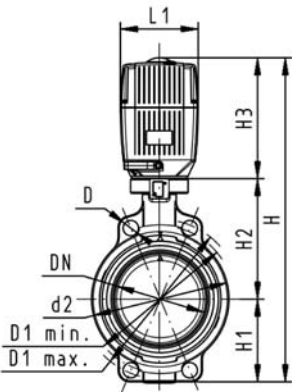

d [mm]	Actuator unit type	D [mm]	D1 min. [mm]	D1 max. [mm]	d2 [mm]	H [mm]	H1 [mm]	H2 [mm]	H3 [mm]	L [mm]	L1 [mm]	L2 [mm]	Q1 [mm]
63	EA-31	19	120.0	125.0	104	400	77	134	188	45	122	180	40
75	EA-31	19	139.7	145.0	115	413	83	140	188	46	122	180	54
90	EA-31	19	150.0	160.0	131	428	89	146	188	49	122	180	67
110	EA-31	19	175.0	190.5	161	460	104	167	188	56	122	180	88
140	EA-31	23	210.0	215.9	187	487	117	181	188	64	122	180	113
160	EA-31	24	241.3	241.3	215	508	130	189	188	72	122	180	139
225	EA-42	23	290.0	295.0	267	575	158	210	208	73	122	180	178

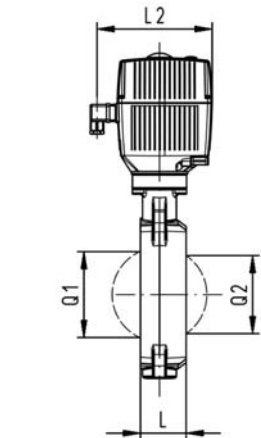

d [mm]	Q2 [mm]
63	
75	35
90	50
110	74
140	97
160	123
225	169

PF 3 39 643



SYGEF® standard Butterfly valve type 140 100-230V With manual override

E

Model:

- Connecting dimension: ISO 7005 PN 10, EN 1092 PN 10, DIN 2501 PN 10, ANSI B 16.5 Class 150, BS 1560: 1989, BS 4504, JIS B 2220
- Overall length according to EN 558-1, ISO 5752
- Voltage 100-230 V, 50-60 Hz
- Control time 15 s/90°<) EA31
- Control time 25s/90°<) EA42
- Control range 90°<)
- Actuator with integrated emergency manual override standard

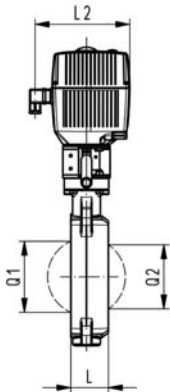
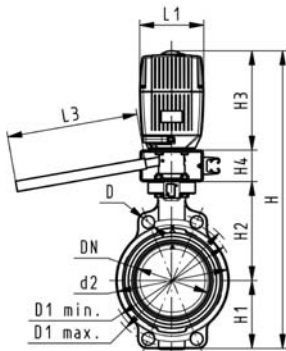

d [mm]	DN [mm]	Inch	PN	kv-value ($\Delta p=1$ bar) [l/min]	FPM Code	kg
63	50	2	10	1470	199 140 562	5.718
75	65	2 ½	10	2200	199 140 563	5.830
90	80	3	10	3000	199 140 564	6.010
110	100	4	10	6500	199 140 565	6.662
140	125	5	10	11500	199 140 566	7.257
160	150	6	10	16600	199 140 567	8.477
225	200	8	10	39600	199 140 568	15.138

d [mm]	Actuator unit type	D [mm]	D1 min. [mm]	D1 max. [mm]	d2 [mm]	H [mm]	H1 [mm]	H2 [mm]	H3 [mm]	H4 [mm]	L [mm]	L1 [mm]	L2 [mm]
63	EA-31	19	120.0	125.0	104	460	77	134	188	60	45	122	180
75	EA-31	19	139.7	145.0	115	473	83	140	188	60	46	122	180
90	EA-31	19	150.0	160.0	131	488	89	146	188	60	49	122	180
110	EA-31	19	175.0	190.5	161	520	104	167	188	60	56	122	180
140	EA-31	23	210.0	215.9	187	547	117	181	188	60	64	122	180
160	EA-31	24	241.3	241.3	215	568	130	189	188	60	72	122	180
225	EA-42	23	290.0	295.0	267	635	158	210	208	60	73	122	180

d [mm]	L3 [mm]	Q1 [mm]	Q2 [mm]
63	250	40	
75	250	54	35
90	250	67	50
110	250	88	74
140	250	113	97
160	250	139	123
225	250	178	169

PF 3 39 643



SYGEF® standard Butterfly valve type 140 24V Without manual override

E

Model:

- Connecting dimension: ISO 7005 PN 10, EN 1092 PN 10, DIN 2501 PN 10, ANSI B 16.5 Class 150, BS 1560: 1989, BS 4504, JIS B 2220
- Overall length according to EN 558-1, ISO 5752
- Voltage 24 V AC/DC
- Control time 15 s/90°<) EA31
- Control time 25s/90°<) EA42
- Control range 90°<)
- Actuator with integrated emergency manual override standard

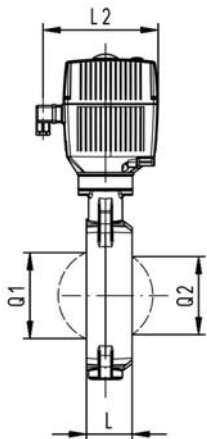
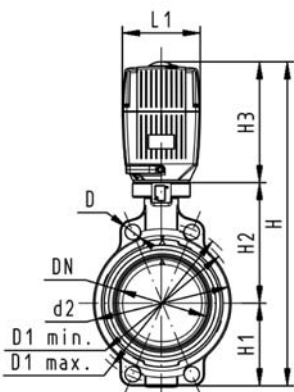

d [mm]	DN [mm]	Inch	PN	kv-value ($\Delta p=1$ bar) [l/min]	FPM Code	kg
63	50	2	10	1470	199 140 622	4.218
75	65	2 ½	10	2200	199 140 623	4.330
90	80	3	10	3000	199 140 624	4.510
110	100	4	10	6500	199 140 625	5.162
140	125	5	10	11500	199 140 626	5.757
160	150	6	10	16600	199 140 627	6.977
225	200	8	10	39600	199 140 628	13.638

d [mm]	Actuator unit type	D [mm]	D1 min. [mm]	D1 max. [mm]	d2 [mm]	H [mm]	H1 [mm]	H2 [mm]	H3 [mm]	L [mm]	L1 [mm]	L2 [mm]	Q1 [mm]
63	EA-31	19	120.0	125.0	104	400	77	134	188	45	122	180	40
75	EA-31	19	139.7	145.0	115	413	83	140	188	46	122	180	54
90	EA-31	19	150.0	160.0	131	428	89	146	188	49	122	180	67
110	EA-31	19	175.0	190.5	161	460	104	167	188	56	122	180	88
140	EA-31	23	210.0	215.9	187	487	117	181	188	64	122	180	113
160	EA-31	24	241.3	241.3	215	508	130	189	188	72	122	180	139
225	EA-42	23	290.0	295.0	267	575	158	210	208	73	122	180	178

d [mm]	Q2 [mm]
63	
75	35
90	50
110	74
140	97
160	123
225	169

PF 3 39 643



SYGEF® standard Butterfly valve type 140 24V With manual override

E

Model:

- Connecting dimension: ISO 7005 PN 10, EN 1092 PN 10, DIN 2501 PN 10, ANSI B 16.5 Class 150, BS 1560: 1989, BS 4504, JIS B 2220
- Overall length according to EN 558-1, ISO 5752
- Voltage 24 V AC/DC
- Control time 15 s/90°<) EA31
- Control time 25s/90°<) EA42
- Control range 90°<)
- Actuator with integrated emergency manual override standard

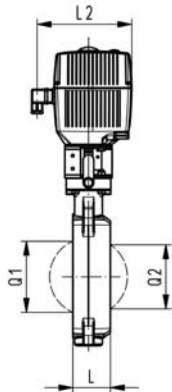
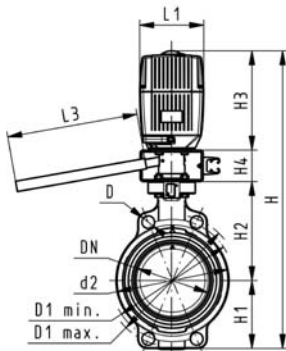

d [mm]	DN [mm]	Inch	PN	kv-value ($\Delta p=1$ bar) [l/min]	FPM Code	kg
63	50	2	10	1470	199 140 602	5.718
75	65	2 ½	10	2200	199 140 603	5.830
90	80	3	10	3000	199 140 604	6.010
110	100	4	10	6500	199 140 605	6.662
140	125	5	10	11500	199 140 606	7.257
160	150	6	10	16600	199 140 607	8.477
225	200	8	10	39600	199 140 608	15.138

d [mm]	Actuator unit type	D [mm]	D1 min. [mm]	D1 max. [mm]	d2 [mm]	H [mm]	H1 [mm]	H2 [mm]	H3 [mm]	H4 [mm]	L [mm]	L1 [mm]	L2 [mm]
63	EA-31	19	120.0	125.0	104	460	77	134	188	60	45	122	180
75	EA-31	19	139.7	145.0	115	473	83	140	188	60	46	122	180
90	EA-31	19	150.0	160.0	131	488	89	146	188	60	49	122	180
110	EA-31	19	175.0	190.5	161	520	104	167	188	60	56	122	180
140	EA-31	23	210.0	215.9	187	547	117	181	188	60	64	122	180
160	EA-31	24	241.3	241.3	215	568	130	189	188	60	72	122	180
225	EA-42	23	290.0	295.0	267	635	158	210	208	60	73	122	180

d [mm]	L3 [mm]	Q1 [mm]	Q2 [mm]
63	250	40	
75	250	54	35
90	250	67	50
110	250	88	74
140	250	113	97
160	250	139	123
225	250	178	169

PF 3 39 643



SYGEF® standard Lugstyle butterfly valve type 141 100-230V Without manual override

E

Model:

- Outer body in GGG-40.3 epoxy-coated
- Connecting dimension: ISO 7005 PN10, EN 1092 PN 10, DIN 2501 PN10
- Overall length according to EN 558-1, ISO 5752
- Voltage 100-230 V, 50-60 Hz
- Control time 15 s/90°<) EA31
- Control time 25s/90°<) EA42
- Control range 90°<)
- Actuator with integrated emergency manual override standard

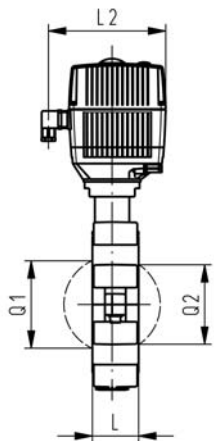
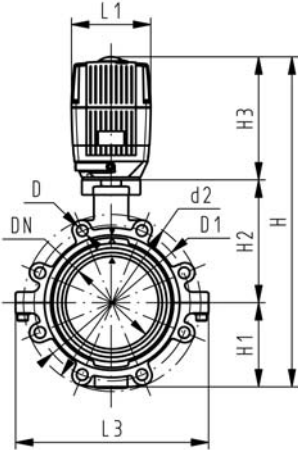

d [mm]	DN [mm]	Inch	PN	kv-value ($\Delta p=1$ bar) [l/min]	FPM Code	kg
63	50	2	10	1470	199 141 582	6.308
75	65	2 ½	10	2200	199 141 583	6.671
90	80	3	10	3000	199 141 584	7.728
110	100	4	10	6500	199 141 585	9.260
140	125	5	10	11500	199 141 586	11.241
160	150	6	10	16600	199 141 587	13.460
225	200	8	10	39600	199 141 588	23.614

d [mm]	Actuator unit type	D	D1 [mm]	d2 [mm]	H [mm]	H1 [mm]	H2 [mm]	H3 [mm]	L [mm]	L1 [mm]	L2 [mm]	L3 [mm]	Q1 [mm]	Q2 [mm]
63	EA-31	M16	125	150	399	77	134	188	45	122	180	150	40	
75	EA-31	M16	145	170	411	83	140	188	46	122	180	160	54	35
90	EA-31	M16	160	184	423	89	146	188	49	122	180	205	67	50
110	EA-31	M16	180	216	459	104	167	188	56	122	180	244	88	74
140	EA-31	M16	210	246	486	117	181	188	64	122	180	272	113	97
160	EA-31	M20	240	273	507	130	189	188	72	122	180	297	139	123
225	EA-42	M20	295	334	576	158	210	208	73	122	180	360	178	169

PF 3 39 643



SYGEF® standard Lugstyle butterfly valve type 141 24V Without manual override

E

Model:

- Outer body in GGG-40.3 epoxy-coated
- Connecting dimension: ISO 7005 PN10, EN 1092 PN 10, DIN 2501 PN10
- Overall length according to EN 558-1, ISO 5752
- Voltage 24 V AC/DC
- Control time 15 s/90°<) EA31
- Control time 25s/90°<) EA42
- Control range 90°<)
- Actuator with integrated emergency manual override standard

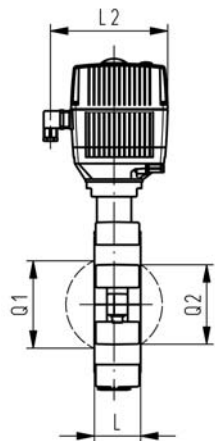
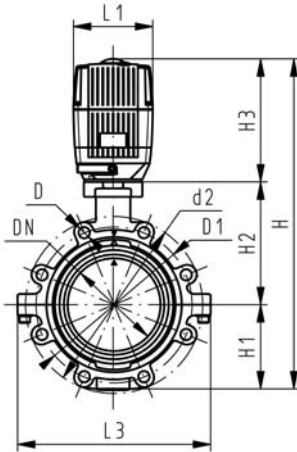

d [mm]	DN [mm]	Inch	PN	kv-value ($\Delta p=1$ bar) [l/min]	FPM Code	kg
63	50	2	10	1470	199 141 622	6.308
75	65	2 ½	10	2200	199 141 623	6.671
90	80	3	10	3000	199 141 624	7.728
110	100	4	10	6500	199 141 625	9.260
140	125	5	10	11500	199 141 626	11.241
160	150	6	10	16600	199 141 627	13.460
225	200	8	10	39600	199 141 628	23.614

d [mm]	Actuator unit type	D	D1 [mm]	d2 [mm]	H [mm]	H1 [mm]	H2 [mm]	H3 [mm]	L [mm]	L1 [mm]	L2 [mm]	L3 [mm]	Q1 [mm]	Q2 [mm]
63	EA-31	M16	125	150	399	77	134	188	45	122	180	150	40	
75	EA-31	M16	145	170	411	83	140	188	46	122	180	160	54	35
90	EA-31	M16	160	184	423	89	146	188	49	122	180	205	67	50
110	EA-31	M16	180	216	459	104	167	188	56	122	180	244	88	74
140	EA-31	M16	210	246	486	117	181	188	64	122	180	272	113	97
160	EA-31	M20	240	273	507	130	189	188	72	122	180	297	139	123
225	EA-42	M20	295	334	576	158	210	208	73	122	180	360	178	169

PF 3 39 643



SYGEF® standard
Lugstyle butterfly valve type 142
100-230V ANSI
Without manual override

E

Model:

- Outer body in GGG-40.3 epoxy-coated
- Connecting dimension ANSI B 16.5 Class 150
- Overall length according to EN 558-1, ISO 5752
- Voltage 100-230 V, 50-60 Hz
- Control time 15 s/90°<) EA31
- Control time 25s/90°<) EA42
- Control range 90°<)
- Actuator with integrated emergency manual override standard

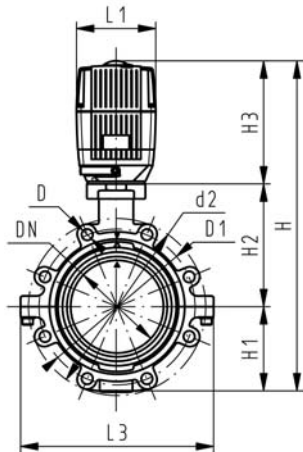

Inch	DN [mm]	d [mm]	PN	kv-value ($\Delta p=1$ bar) [l/min]	FPM Code	kg
2	50	63	10	1470	199 142 582	6.308
2 ½	65	75	10	2200	199 142 583	6.671
3	80	90	10	3000	199 142 584	7.099
4	100	110	10	6500	199 142 585	9.260
5	125	140	10	11500	199 142 586	11.241
6	150	160	10	16600	199 142 587	13.460
8	200	225	10	39600	199 142 588	23.614

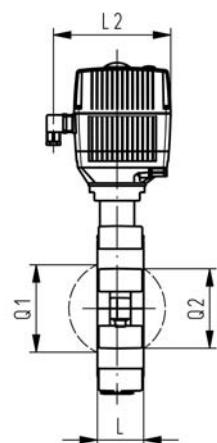

Inch	Actuator unit type	D	D1 [mm]	d2 [mm]	H [mm]	H1 [mm]	H2 [mm]	H3 [mm]	L [mm]	L1 [mm]	L2 [mm]	L3 [mm]	Q1 [mm]
2	EA-31	UNC 5/8	121	150	399	77	134	188	45	122	180	150	40
2 ½	EA-31	UNC 5/8	140	170	411	83	140	188	46	122	180	160	54
3	EA-31	UNC 5/8	153	177	423	89	146	188	49	122	180	175	67
4	EA-31	UNC 5/8	191	216	459	104	167	188	56	122	180	244	88
5	EA-31	UNC 3/4	216	246	486	117	181	188	64	122	180	272	113
6	EA-31	UNC 3/4	242	273	507	130	189	188	72	122	180	297	139
8	EA-42	UNC 3/4	299	334	576	158	210	208	73	122	180	360	178

Inch	Q2 [mm]
2	
2 ½	35
3	50
4	74
5	97
6	123
8	169

PF 3 39 643

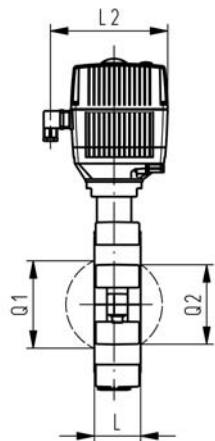
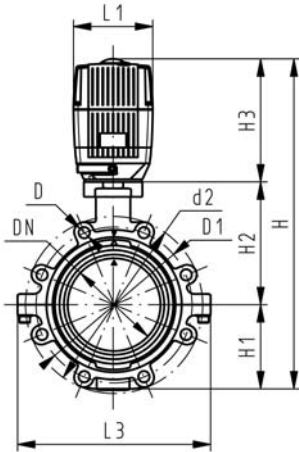

SYGEF® standard Lugstyle butterfly valve type 142 24V ANSI Without manual override

E

Model:

- Outer body in GGG-40.3 epoxy-coated
- Connecting dimension ANSI B 16.5 Class 150
- Overall length according to EN 558-1, ISO 5752
- Voltage 24 V AC/DC
- Control time 15 s/90°<) EA31
- Control time 25s/90°<) EA42
- Control range 90°<)
- Actuator with integrated emergency manual override standard

Inch	DN [mm]	d [mm]	PN	kv-value ($\Delta p=1$ bar) [l/min]	FPM Code	kg
2	50	63	10	1470	199 142 622	6.308
2 ½	65	75	10	2200	199 142 623	6.671
3	80	90	10	3000	199 142 624	7.099
4	100	110	10	6500	199 142 625	9.260
5	125	140	10	11500	199 142 626	11.241
6	150	160	10	16600	199 142 627	13.460
8	200	225	10	39600	199 142 628	23.614

Inch	Actuator unit type	D	D1 [mm]	d2 [mm]	H [mm]	H1 [mm]	H2 [mm]	H3 [mm]	L [mm]	L1 [mm]	L2 [mm]	L3 [mm]	Q1 [mm]
2	EA-31	UNC 5/8	121	150	399	77	134	188	45	122	180	150	40
2 ½	EA-31	UNC 5/8	140	170	411	83	140	188	46	122	180	160	54
3	EA-31	UNC 5/8	153	177	423	89	146	188	49	122	180	175	67
4	EA-31	UNC 5/8	191	216	459	104	167	188	56	122	180	244	88
5	EA-31	UNC 3/4	216	246	486	117	181	188	64	122	180	272	113
6	EA-31	UNC 3/4	242	273	507	130	189	188	72	122	180	297	139
8	EA-42	UNC 3/4	299	334	576	158	210	208	73	122	180	360	178

Inch	Q2 [mm]
2	
2 ½	35
3	50
4	74
5	97
6	123
8	169

PF 3 39 643

Butterfly valves pneumatic

SYGEF® standard Butterfly valve type 240 FC (Fail safe to close) Without manual override

E

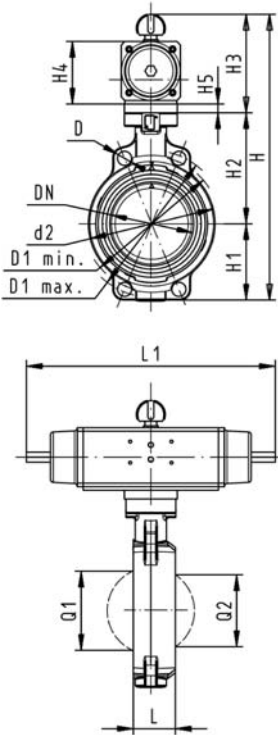

Model:

- Connecting dimension: ISO 7005 PN 10, EN 1092 PN 10, DIN 2501 PN 10, ANSI B 16.5 Class 150, BS 1560: 1989, BS 4504, JIS B 2220
- Overall length according to EN 558-1, ISO 5752
- Control range 90°<

d [mm]	DN [mm]	Inch	PN	kv-value ($\Delta p=1$ bar) [l/min]	FPM Code	kg
63	50	2	10	1470	199 240 462	3.258
75	65	2 ½	10	2200	199 240 463	3.370
90	80	3	10	3000	199 240 464	3.550
110	100	4	10	6500	199 240 465	5.400
140	125	5	10	11500	199 240 466	6.997
160	150	6	10	16600	199 240 467	10.538
225	200	8	10	39600	199 240 468	15.138

d [mm]	Actuator unit type	D [mm]	D1 min. [mm]	D1 max. [mm]	d2 [mm]	H [mm]	H1 [mm]	H2 [mm]	H3 [mm]	H4 [mm]	H5 [mm]	L [mm]	L1 [mm]
63	PA-30 FC	19	120.0	125.0	104	327	77	134	117	70	15	45	276
75	PA-30 FC	19	139.7	145.0	115	340	83	140	117	70	15	46	276
90	PA-35 FC	19	150.0	160.0	131	361	89	146	126	78	15	49	326
110	PA-40 FC	19	175.0	190.5	161	400	104	167	129	86		56	370
140	PA-45 FC	23	210.0	215.9	187	436	117	181	139	96		64	411
160	PA-50 FC	24	241.3	241.3	215	468	130	189	149	106		72	423
225	PA-55 FC	23	290.0	295.0	267	529	158	210	161	118		73	452

d [mm]	L2 [mm]	Q1 [mm]	Q2 [mm]
63	65	40	
75	65	54	35
90	72	67	50
110	80	88	74
140	90	113	97
160	100	139	123
225	112	178	169

PF 3 39 644

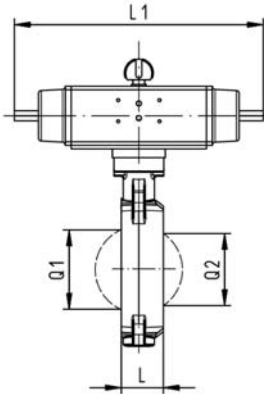
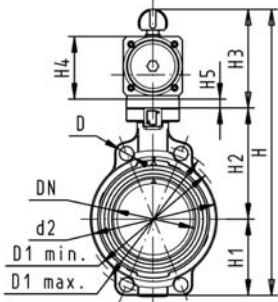

SYGEF® standard
Butterfly valve type 240
FO (Fail safe to open)
Without manual override

E

Model:

- Connecting dimension: ISO 7005 PN 10, EN 1092 PN 10, DIN 2501 PN 10, ANSI B 16.5 Class 150, BS 1560: 1989, BS 4504, JIS B 2220
- Overall length according to EN 558-1, ISO 5752
- Control range 90°<

d [mm]	DN [mm]	Inch	PN	kv-value ($\Delta p=1$ bar) [l/min]	FPM Code	kg
63	50	2	10	1470	199 240 482	3.258
75	65	2 ½	10	2200	199 240 483	3.370
90	80	3	10	3000	199 240 484	3.550
110	100	4	10	6500	199 240 485	5.400
140	125	5	10	11500	199 240 486	6.997
160	150	6	10	16600	199 240 487	10.538
225	200	8	10	39600	199 240 488	15.138

d [mm]	Actuator unit type	D [mm]	D1 min. [mm]	D1 max. [mm]	d2 [mm]	H [mm]	H1 [mm]	H2 [mm]	H3 [mm]	H4 [mm]	H5 [mm]	L [mm]	L1 [mm]
63	PA-30 FO	19	120.0	125.0	104	327	77	134	117	70	15	45	276
75	PA-30 FO	19	139.7	145.0	115	340	83	140	117	70	15	46	276
90	PA-35 FO	19	150.0	160.0	131	361	89	146	126	78	15	49	326
110	PA-40 FO	19	175.0	190.5	161	400	104	167	129	86		56	370
140	PA-45 FO	23	210.0	215.9	187	436	117	181	139	96		64	411
160	PA-50 FO	24	241.3	241.3	215	468	130	189	149	106		72	423
225	PA-55 FO	23	290.0	295.0	267	529	158	210	161	118		73	452

d [mm]	L2 [mm]	Q1 [mm]	Q2 [mm]
63	65	40	
75	65	54	35
90	72	67	50
110	80	88	74
140	90	113	97
160	100	139	123
225	112	178	169

PF 3 39 644



SYGEF® standard Butterfly valve type 240 DA (Double acting) Without manual override

E

Model:

- Connecting dimension: ISO 7005 PN 10, EN 1092 PN 10, DIN 2501 PN 10, ANSI B 16.5 Class 150, BS 1560: 1989, BS 4504, JIS B 2220
- Overall length according to EN 558-1, ISO 5752
- Control range 90°<

d [mm]	DN [mm]	Inch	PN	kv-value ($\Delta p=1$ bar) [l/min]	FPM Code	kg
63	50	2	10	1470	199 240 502	2.108
75	65	2 ½	10	2200	199 240 503	2.220
90	80	3	10	3000	199 240 504	2.881
110	100	4	10	6500	199 240 505	3.652
140	125	5	10	11500	199 240 506	4.247
160	150	6	10	16600	199 240 507	7.017
225	200	8	10	39600	199 240 508	9.138

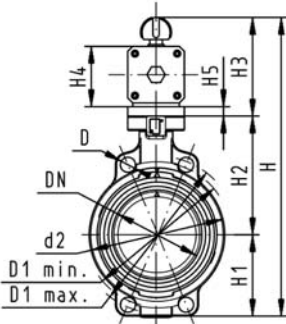

d [mm]	Actuator unit type	D [mm]	D1 min. [mm]	D1 max. [mm]	d2 [mm]	H [mm]	H1 [mm]	H2 [mm]	H3 [mm]	H4 [mm]	H5 [mm]	L [mm]	L1 [mm]
63	PA-35 DA	19	120.0	125.0	104	317	77	134	107	60	15	45	177
75	PA-35 DA	19	139.7	145.0	115	330	83	140	107	60	15	46	177
90	PA-40 DA	19	150.0	160.0	131	348	89	146	113	66	15	49	190
110	PA-45 DA	19	175.0	190.5	161	372	104	167	102	71		56	198
140	PA-45 DA	23	210.0	215.9	187	408	117	181	111	78		64	235
160	PA-55 DA	24	241.3	241.3	215	448	130	189	129	86		72	250
225	PA-55 DA	23	290.0	295.0	267	507	158	210	139	96		73	279

d [mm]	L2 [mm]	Q1 [mm]	Q2 [mm]
63	55	40	
75	55	54	35
90	60	67	50
110	65	88	74
140	72	113	97
160	80	139	123
225	90	178	169

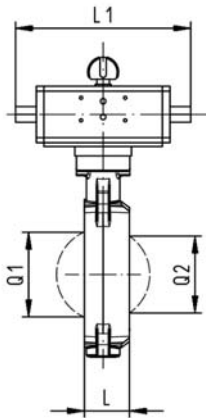

PF 3 39 644



SYGEF® standard Lugstyle butterfly valve type 241 FC (Fail safe to close) Without manual override

E

Model:

- Outer body in GGG-40.3 epoxy-coated
- Connecting dimension: ISO 7005 PN10, EN 1092 PN 10, DIN 2501 PN10
- Overall length according to EN 558-1, ISO 5752
- Control range 90°<

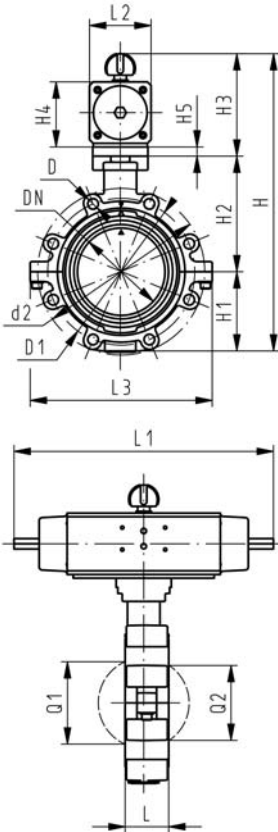

d [mm]	DN [mm]	Inch	PN	kv-value ($\Delta p=1$ bar) [l/min]	FPM Code	kg
63	50	2	10	1470	199 241 462	5.348
75	65	2 ½	10	2200	199 241 463	5.711
90	80	3	10	3000	199 241 464	6.768
110	100	4	10	6500	199 241 465	9.498
140	125	5	10	11500	199 241 466	12.481
160	150	6	10	16600	199 241 467	17.021
225	200	8	10	39600	199 241 468	25.114

d [mm]	Actuator unit type	D	D1 [mm]	d2 [mm]	H [mm]	H1 [mm]	H2 [mm]	H3 [mm]	H4 [mm]	H5 [mm]	L [mm]	L1 [mm]	L2 [mm]	L3 [mm]
63	PA-30 FC	M16	125	150	328	77	134	117	70	15	45	276	65	150
75	PA-30 FC	M16	145	170	340	83	140	117	70	15	46	276	65	160
90	PA-35 FC	M16	160	184	361	89	146	126	78	15	49	326	72	205
110	PA-40 FC	M16	180	216	400	104	167	129	86		56	370	80	244
140	PA-45 FC	M16	210	246	437	117	181	139	96		64	411	90	272
160	PA-50 FC	M20	240	273	468	130	189	149	106		72	423	100	297
225	PA-55 FC	M20	295	334	529	158	210	161	118		73	452	112	360

d [mm]	Q1 [mm]	Q2 [mm]
63	40	
75	54	35
90	67	50
110	88	74
140	113	97
160	139	123
225	178	169

PF 3 39 644



SYGEF® standard Lugstyle butterfly valve type 241 FO (Fail safe to open) Without manual override

E

Model:

- Outer body in GGG-40.3 epoxy-coated
- Connecting dimension: ISO 7005 PN10, EN 1092 PN 10, DIN 2501 PN10
- Overall length according to EN 558-1, ISO 5752
- Control range 90°<

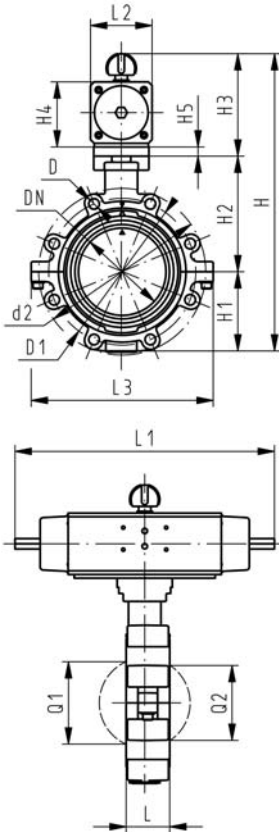

d [mm]	DN [mm]	Inch	PN	kv-value ($\Delta p=1$ bar) [l/min]	FPM Code	kg
63	50	2	10	1470	199 241 482	5.348
75	65	2 ½	10	2200	199 241 483	5.711
90	80	3	10	3000	199 241 484	6.768
110	100	4	10	6500	199 241 485	9.498
140	125	5	10	11500	199 241 486	12.481
160	150	6	10	16600	199 241 487	17.021
225	200	8	10	39600	199 241 488	25.114

d [mm]	Actuator unit type	D	D1 [mm]	d2 [mm]	H [mm]	H1 [mm]	H2 [mm]	H3 [mm]	H4 [mm]	H5 [mm]	L [mm]	L1 [mm]	L2 [mm]	L3 [mm]
63	PA-30 FO	M16	125	150	328	77	134	117	70	15	45	276	65	150
75	PA-30 FO	M16	145	170	340	83	140	117	70	15	46	276	65	160
90	PA-35 FO	M16	160	184	361	89	146	126	78	15	49	326	72	205
110	PA-40 FO	M16	180	216	400	104	167	129	86		56	370	80	244
140	PA-45 FO	M16	210	246	437	117	181	139	96		64	411	90	272
160	PA-50 FO	M20	240	273	468	130	189	149	106		72	423	100	297
225	PA-55 FO	M20	295	334	529	158	210	161	118		73	452	112	360

d [mm]	Q1 [mm]	Q2 [mm]
63	40	
75	54	35
90	67	50
110	88	74
140	113	97
160	139	123
225	178	169

PF 3 39 644



SYGEF® standard Lugstyle butterfly valve type 241 DA (Double acting) Without manual override

E

Model:

- Outer body in GGG-40.3 epoxy-coated
- Connecting dimension: ISO 7005 PN10, EN 1092 PN 10, DIN 2501 PN10
- Overall length according to EN 558-1, ISO 5752
- Control range 90°<

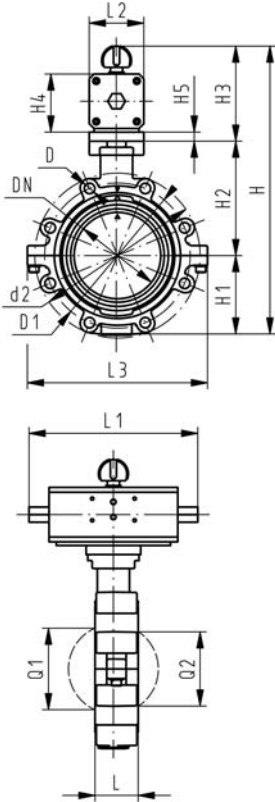

d [mm]	DN [mm]	Inch	PN	kv-value ($\Delta p=1$ bar) [l/min]	FPM Code	kg
63	50	2	10	1470	199 241 502	4.198
75	65	2 ½	10	2200	199 241 503	4.561
90	80	3	10	3000	199 241 504	6.099
110	100	4	10	6500	199 241 505	7.750
140	125	5	10	11500	199 241 506	9.731
160	150	6	10	16600	199 241 507	13.500
225	200	8	10	39600	199 241 508	19.114

d [mm]	Actuator unit type	D	D1 [mm]	d2 [mm]	H [mm]	H1 [mm]	H2 [mm]	H3 [mm]	H4 [mm]	H5 [mm]	L [mm]	L1 [mm]	L2 [mm]	L3 [mm]
63	PA-35 DA	M16	125	150	318	77	134	107	60	15	45	177	55	150
75	PA-35 DA	M16	145	170	330	83	140	107	60	15	46	177	55	160
90	PA-40 DA	M16	160	184	348	89	146	113	66	15	49	190	60	205
110	PA-45 DA	M16	180	216	373	104	167	102	71		56	198	65	244
140	PA-45 DA	M16	210	246	409	117	181	111	78		64	235	72	272
160	PA-55 DA	M20	240	273	448	130	189	129	86		72	250	80	297
225	PA-55 DA	M20	295	334	507	158	210	139	96		73	279	90	360

d [mm]	Q1 [mm]	Q2 [mm]
63	40	
75	54	35
90	67	50
110	88	74
140	113	97
160	139	123
225	178	169

PF 3 39 644



SYGEF® standard Lugstyle butterfly valve type 242 ANSI FC (Fail safe to close) Without manual override

E

Model:

- Outer body in GGG-40.3 epoxy-coated
- Connecting dimension ANSI B 16.5 Class 150
- Overall length according to EN 558-1, ISO 5752
- Control range 90°<

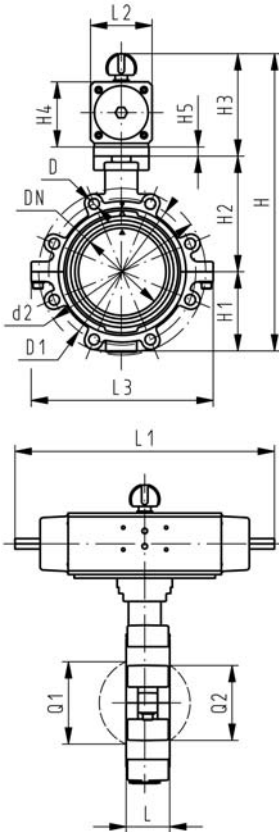

Inch	DN [mm]	d [mm]	PN	kv-value ($\Delta p=1$ bar) [l/min]	FPM Code	kg
2	50	63	10	1470	199 242 462	5.348
2 ½	65	75	10	2200	199 242 463	5.711
3	80	90	10	3000	199 242 464	6.139
4	100	110	10	6500	199 242 465	9.498
5	125	140	10	11500	199 242 466	12.481
6	150	160	10	16600	199 242 467	17.021
8	200	225	10	39600	199 242 468	25.114

Inch	Actuator unit type	D	D1 [mm]	d2 [mm]	H [mm]	H1 [mm]	H2 [mm]	H3 [mm]	H4 [mm]	H5 [mm]	L [mm]	L1 [mm]	L2 [mm]
2	PA-30 FC	UNC 5/8	121	150	328	77	134	117	70	15	45	276	65
2 ½	PA-30 FC	UNC 5/8	140	170	340	83	140	117	70	15	46	276	65
3	PA-35 FC	UNC 5/8	153	177	361	89	146	126	78	15	49	326	72
4	PA-40 FC	UNC 5/8	191	216	400	104	167	129	86		56	370	80
5	PA-45 FC	UNC 3/4	216	246	437	117	181	139	96		64	411	90
6	PA-50 FC	UNC 3/4	242	273	468	130	189	149	106		72	423	100
8	PA-55 FC	UNC 3/4	299	334	529	158	210	161	118		73	452	112

Inch	L3 [mm]	Q1 [mm]	Q2 [mm]
2	150	40	
2 ½	160	54	35
3	175	67	50
4	244	88	74
5	272	113	97
6	297	139	123
8	360	178	169

PF 3 39 644



SYGEF® standard
Lugstyle butterfly valve type 242 ANSI
FO (Fail safe to open)
Without manual override

E

Model:

- Outer body in GGG-40.3 epoxy-coated
- Connecting dimension ANSI B 16.5 Class 150
- Overall length according to EN 558-1, ISO 5752
- Control range 90°<

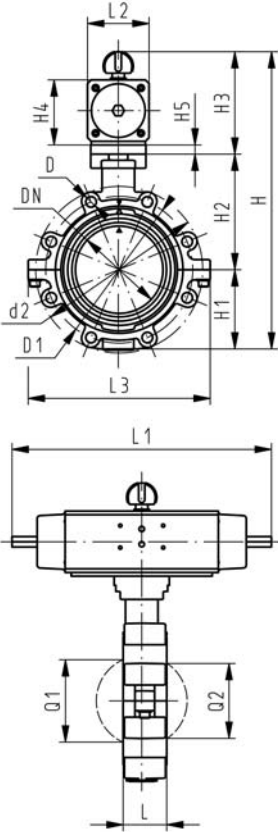

Inch	DN [mm]	d [mm]	PN	kv-value ($\Delta p=1$ bar) [l/min]	FPM Code	kg
2	50	63	10	1470	199 242 482	5.348
2 ½	65	75	10	2200	199 242 483	5.711
3	80	90	10	3000	199 242 484	6.139
4	100	110	10	6500	199 242 485	9.498
5	125	140	10	11500	199 242 486	12.481
6	150	160	10	16600	199 242 487	17.021
8	200	225	10	39600	199 242 488	25.114

Inch	Actuator unit type	D	D1 [mm]	d2 [mm]	H [mm]	H1 [mm]	H2 [mm]	H3 [mm]	H4 [mm]	H5 [mm]	L [mm]	L1 [mm]	L2 [mm]
2	PA-30 FO	UNC 5/8	121	150	328	77	134	117	70	15	45	276	65
2 ½	PA-30 FO	UNC 5/8	140	170	340	83	140	117	70	15	46	276	65
3	PA-35 FO	UNC 5/8	153	177	361	89	146	126	78	15	49	326	72
4	PA-40 FO	UNC 5/8	191	216	400	104	167	129	86		56	370	80
5	PA-45 FO	UNC 3/4	216	246	437	117	181	139	96		64	411	90
6	PA-50 FO	UNC 3/4	242	273	468	130	189	149	106		72	423	100
8	PA-55 FO	UNC 3/4	299	334	529	158	210	161	118		73	452	112

Inch	L3 [mm]	Q1 [mm]	Q2 [mm]
2	150	40	
2 ½	160	54	35
3	175	67	50
4	244	88	74
5	272	113	97
6	297	139	123
8	360	178	169

PF 3 39 644



SYGEF® standard Lugstyle butterfly valve type 242 ANSI DA (Double acting) Without manual override

E

Model:

- Outer body in GGG-40.3 epoxy-coated
- Connecting dimension ANSI B 16.5 Class 150
- Overall length according to EN 558-1, ISO 5752
- Control range 90°<

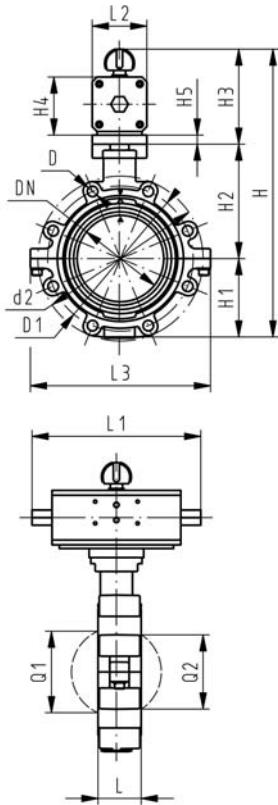

Inch	DN [mm]	d [mm]	PN	kv-value ($\Delta p=1$ bar) [l/min]	FPM Code	kg
2	50	63	10	1470	199 242 502	4.198
2 ½	65	75	10	2200	199 242 503	4.561
3	80	90	10	3000	199 242 504	5.470
4	100	110	10	6500	199 242 505	7.750
5	125	140	10	11500	199 242 506	9.731
6	150	160	10	16600	199 242 507	13.500
8	200	225	10	39600	199 242 508	19.114

Inch	Actuator unit type	D	D1 [mm]	d2 [mm]	H [mm]	H1 [mm]	H2 [mm]	H3 [mm]	H4 [mm]	H5 [mm]	L [mm]	L1 [mm]	L2 [mm]
2	PA-35 DA	UNC 5/8	121	150	318	77	134	107	60	15	45	177	55
2 ½	PA-35 DA	UNC 5/8	140	170	330	83	140	107	60	15	46	177	55
3	PA-40 DA	UNC 5/8	153	177	348	89	146	113	66	15	49	190	60
4	PA-45 DA	UNC 5/8	191	216	373	104	167	102	71		56	198	65
5	PA-45 DA	UNC 3/4	216	246	409	117	181	111	78		64	235	72
6	PA-55 DA	UNC 3/4	242	273	448	130	189	129	86		72	250	80
8	PA-55 DA	UNC 3/4	299	334	507	158	210	139	96		73	279	90

Inch	L3 [mm]	Q1 [mm]	Q2 [mm]
2	150	40	
2 ½	160	54	35
3	175	67	50
4	244	88	74
5	272	113	97
6	297	139	123
8	360	178	169

PF 3 39 644

Solenoid valves

SYGEF® standard Solenoid valve type 165 Standard voltage 230V 50 Hz With fusion sockets metric

E

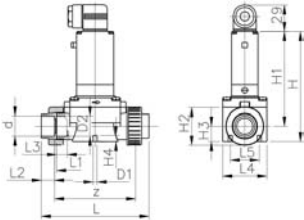

- Solenoid valve 2/2 ways
- Servo assisted
- Function A
- Function B on request
- Attention: Some inner parts in contact with the media are made of PVDF

d [mm]	DN [mm]	PN [bar]	kv-value ($\Delta p=1$ bar) [l/min]	EPDM Code	FPM Code	kg
20	15	0.5 - 6.0	83	199 165 412	199 165 402	0.700
25	20	0.5 - 6.0	100	199 165 413	199 165 403	0.700
32	25	0.5 - 6.0	233	199 165 414	199 165 404	1.200
40	32	0.5 - 6.0	500	199 165 415	199 165 405	1.300
50	40	0.5 - 6.0	500	199 165 416	199 165 406	2.200
63	50	0.5 - 6.0	600	199 165 417	199 165 407	2.200

d [mm]	D2 [mm]	z [mm]	L [mm]	L1 [mm]	L2 [mm]	L3 [mm]	L4 [mm]	L5 [mm]	H [mm]	H1 [mm]	H2 [mm]	H3 [mm]	H4 [mm]
20		120	147	109	16		63	40	148	122	53	22	8
25	25	120	151	109	18	18	62	40	148	122	53	22	8
32		150	185	139	20		85	45	175	137	76	31	15
40	40	150	189	139	22	23	85	45	175	137	76	31	15
50		200	245	189	25		115	45	212	160	105	42	15
63	63	200	253	189	29	33	115	45	212	160	105	42	15

PF 3 39 215

SYGEF® standard Solenoid valve type 165 Standard voltage 115V 50 Hz With fusion sockets metric

E

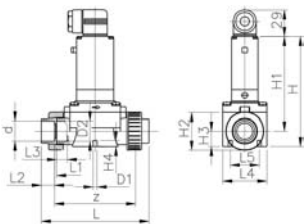

- Solenoid valve 2/2 ways
- Servo assisted
- Function A
- Function B on request
- Attention: Some inner parts in contact with the media are made of PVDF

d [mm]	DN [mm]	PN [bar]	kv-value ($\Delta p=1$ bar) [l/min]	EPDM Code	FPM Code	kg
20	15	0.5 - 6.0	83	199 165 442	199 165 432	0.700
25	20	0.5 - 6.0	100	199 165 443	199 165 433	0.700
32	25	0.5 - 6.0	233	199 165 444	199 165 434	1.200
40	32	0.5 - 6.0	267	199 165 445	199 165 435	1.200
50	40	0.5 - 6.0	500	199 165 446	199 165 436	2.200
63	50	0.5 - 6.0	600	199 165 447	199 165 437	2.200

d [mm]	D2 [mm]	z [mm]	L [mm]	L1 [mm]	L2 [mm]	L3 [mm]	L4 [mm]	L5 [mm]	H [mm]	H1 [mm]	H2 [mm]	H3 [mm]	H4 [mm]
20		120	147	109	16		63	40	148	122	53	22	8
25	25	120	151	109	18	18	62	40	148	122	53	22	8
32		150	185	139	20		85	45	175	137	76	31	15
40	40	150	189	139	22	23	85	45	175	137	76	31	15
50		200	245	189	25		115	45	212	160	105	42	15
63	63	200	253	189	29	33	115	45	212	160	105	42	15

PF 3 39 215



SYGEF® standard
Solenoid valve type 165
Standard voltage 24V DC
With fusion sockets metric

E

- Solenoid valve 2/2 ways
- Servo assisted
- Function A
- Function B on request
- Attention: Some inner parts in contact with the media are made of PVDF

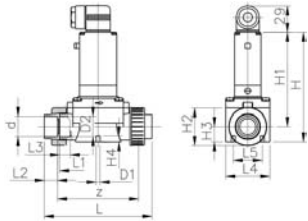

d [mm]	DN [mm]	PN [bar]	kv-value ($\Delta p=1$ bar) [l/min]	EPDM Code	FPM Code	kg
20	15	0.5 - 6.0	83	199 165 422	199 165 452	0.700
25	20	0.5 - 6.0	100	199 165 423	199 165 453	0.700
32	25	0.5 - 6.0	233	199 165 424	199 165 454	1.300
40	32	0.5 - 6.0	267	199 165 425	199 165 455	1.200
50	40	0.5 - 6.0	500	199 165 426	199 165 456	2.200
63	50	0.5 - 6.0	600	199 165 427	199 165 457	2.200

d [mm]	D2 [mm]	z [mm]	L [mm]	L1 [mm]	L2 [mm]	L3 [mm]	L4 [mm]	L5 [mm]	H [mm]	H1 [mm]	H2 [mm]	H3 [mm]	H4 [mm]
20		120	147	109	16		63	40	148	122	53	22	8
25	25	120	151	109	18	18	62	40	148	122	53	22	8
32		150	185	139	20		85	45	175	137	76	31	15
40	40	150	189	139	22	23	85	45	175	137	76	31	15
50		200	245	189	25		115	45	212	160	105	42	15
63	63	200	253	189	29	33	115	45	212	160	105	42	15

PF 3 39 215



SYGEF® standard
Solenoid valve type 166
Function A straight valve 2/2 ways
Nominal voltage 24V DC
With G 1/4 line connection

- With manual override
- Electrical connection: cable plug
- Function C on request
- Voltage 24 VAC 42 VAC 110 VAC on request

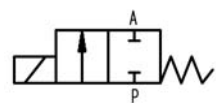
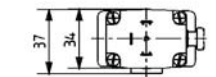
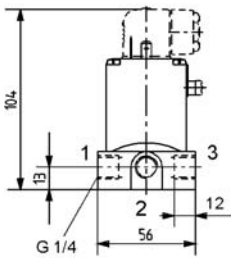

DN [mm]	D1_G [inch]	Func- tion	PN [bar]	kv-value ($\Delta p=1$ bar) [l/min]	FPM Code	kg
3	1/4	A	0.0 - 8.0	4	199 166 505	0.400
4	1/4	A	0.0 - 4.0	5	199 166 506	0.400
5	1/4	A	0.0 - 3.0	6	199 166 507	0.400

PF 3 39 215



SYGEF® standard
Solenoid valve type 166
Function A straight valve 2/2 ways
Nominal voltage 230V 50Hz +-10%
With G 1/4 line connection

- With manual override
- Electrical connection: cable plug
- Function C on request
- Voltage 24 VAC 42 VAC 110 VAC on request

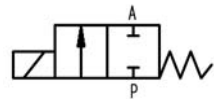
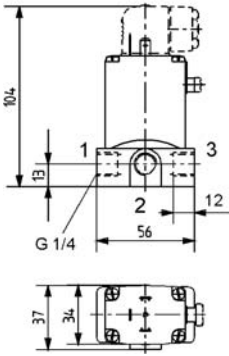

PF 3 39 215

DN [mm]	D1_G [inch]	Func- tion	PN [bar]	kv-value ($\Delta p=1$ bar) [l/min]	FPM Code	kg
3	1/4	A	0.0 - 10.0	4	199 166 515	0.400
4	1/4	A	0.0 - 5.0	5	199 166 516	0.400
5	1/4	A	0.0 - 4.5	6	199 166 517	0.400



SYGEF® standard
Solenoid valve type 166
Function E blending valve 3/2 ways
Nominal voltage 24V DC
With G 1/4 line connection

- With manual override
- Electrical connection: cable plug
- Function C on request
- Voltage 24 VAC 42 VAC 110 VAC on request

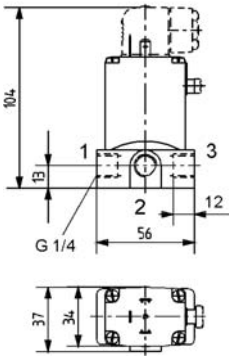

PF 3 39 215

DN [mm]	D1_G [inch]	Func- tion	PN [bar]	kv-value ($\Delta p=1$ bar) [l/min]	FPM Code	kg
4	1/4	E	0.0 - 2.0	5	199 166 656	0.400



SYGEF® standard
Solenoid valve type 166
Function E blending valve 3/2 ways
Nominal voltage 230V 50Hz +-10%
With G 1/4 line connection

- With manual override
- Electrical connection: cable plug
- Function C on request
- Voltage 24 VAC 42 VAC 110 VAC on request

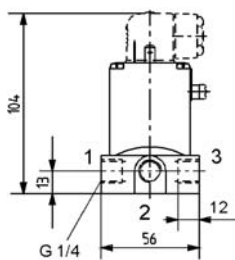

DN [mm]	D1_G [inch]	Func- tion	PN [bar]	kv-value ($\Delta p=1$ bar) [l/min]	FPM Code	kg	
4	1/4	E	0.0 - 3.0	5	199 166 666	0.400	

PF 3 39 215

Process control valves

SYGEF® standard Pressure reducing valve type V 782 With fusion spigots metric

E



PF 3 58 458

d [mm]	DN [mm]	Pressure range [bar]	PTFE Code	kg	D [mm]	L [mm]	L1 [mm]	H [mm]	H1 [mm]
16	10	0.5 - 10	199 041 084	1.300	83	134	102	138	48
20	15	0.5 - 10	199 041 085	1.300	83	134	102	138	48
25	20	0.5 - 10	199 041 086	1.700	113	154	110	205	65
32	25	0.5 - 10	199 041 087	1.700	113	154	110	205	65
40	32	0.5 - 10	199 041 088	4.840	165	224	162	248	95
50	40	0.5 - 10	199 041 089	4.840	165	224	162	248	95

SYGEF® standard Pressure reducing valve type V 82 With fusion spigots metric

E



PF 3 58 458

d [mm]	DN [mm]	Pressure range [bar]	PTFE Code	kg	D [mm]	L [mm]	H [mm]	H1 [mm]
16	10	0.5 - 10	199 041 052	0.790	70	134	130	100
20	15	0.5 - 10	199 041 053	0.790	70	134	130	100
25	20	0.5 - 10	199 041 054	1.620	100	174	170	130
32	25	0.5 - 10	199 041 055	1.620	100	174	170	130
40	32	0.5 - 10	199 041 056	3.150	130	224	230	175
50	40	0.5 - 10	199 041 057	3.150	130	224	230	175
63	50	0.5 - 10	199 041 058	5.700	155	244	285	210
75	65	0.5 - 6	199 041 059	11.600	190	284	350	250

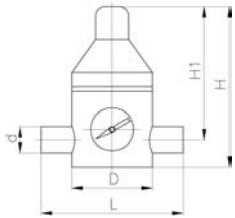

PF 3 58 458

SYGEF® standard Pressure reducing valve type V 182 With fusion spigots metric

d [mm]	DN [mm]	Pressure range [bar]	FPM Code	kg	D [mm]	L [mm]	H [mm]	H1 [mm]
16	10	0.5 - 10	199 041 661	0.790	70	134	130	100
20	15	0.5 - 10	199 041 662	0.790	70	134	130	100
25	20	0.5 - 10	199 041 663	1.620	100	174	170	130
32	25	0.5 - 10	199 041 664	1.620	100	174	170	130
40	32	0.5 - 10	199 041 665	3.150	130	224	230	175
50	40	0.5 - 10	199 041 666	3.150	130	224	230	175

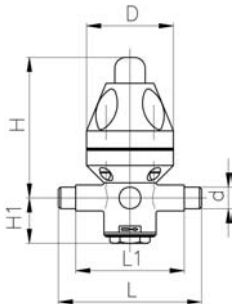

PF 3 58 458

SYGEF® standard Pressure retaining valve type V 786 With fusion spigots metric

E

d [mm]	DN [mm]	Pressure range [bar]	PTFE Code	kg	D [mm]	L [mm]	L1 [mm]	H [mm]	H1 [mm]
16	10	0.5 - 10	199 041 114	0.620	83	134	102	138	38
20	15	0.5 - 10	199 041 115	0.620	83	134	102	158	38
25	20	0.5 - 10	199 041 116	1.700	113	154	110	205	55
32	25	0.5 - 10	199 041 117	1.700	113	154	110	205	55
40	32	0.5 - 4	199 041 118	4.840	165	224	162	248	85
50	40	0.5 - 4	199 041 119	4.840	165	224	162	248	85



SYGEF® standard
Pressure retaining valve type V 186
With fusion spigots metric

E

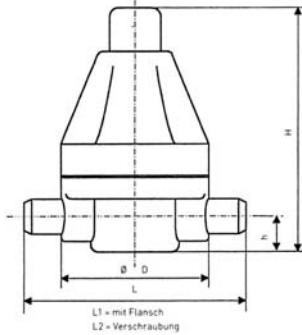

PF 3 58 458

d [mm]	DN [mm]	Pressure range [bar]	PTFE Code	kg	D [mm]	L [mm]	H [mm]	H1 [mm]	
16	10	0.5 - 10	199 041 323	0.600	83	134	137	20	
20	15	0.5 - 10	199 041 324	0.600	83	134	137	20	
25	20	0.5 - 10	199 041 325	0.600	83	134	137	20	
32	25	0.5 - 10	199 041 326	1.600	112	174	199	27	
40	32	0.5 - 10	199 041 327	1.600	112	174	199	27	
50	40	0.5 - 10	199 041 328	8.000	165	224	290	43	
63	50	0.5 - 10	199 041 329	8.200	165	244	290	43	



SYGEF® standard
Pressure retaining valve type V 86
With fusion spigots metric

E

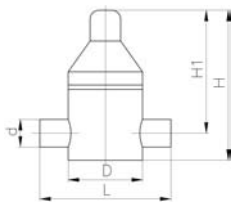

PF 3 58 458

d [mm]	DN [mm]	Pressure range [bar]	PTFE Code	kg	D [mm]	L [mm]	H [mm]	H1 [mm]	
75	65	1.0 - 6	199 041 892	7.730	180	284	275	230	



SYGEF® standard
Pressure relief valve type V 185
With fusion spigots metric

E

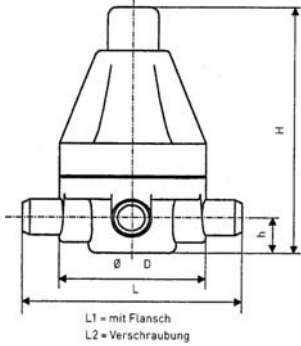

PF 3 58 458

d [mm]	DN [mm]	Pressure range [bar]	PTFE Code	kg	D [mm]	L [mm]	H [mm]	H1 [mm]	
16	10	0.5 - 10	199 041 344	0.700	83	134	137	20	
20	15	0.5 - 10	199 041 345	0.700	83	134	137	20	
25	20	0.5 - 10	199 041 346	0.700	83	134	137	20	
32	25	0.5 - 10	199 041 347	1.700	112	174	199	27	
40	32	0.5 - 10	199 041 348	1.700	112	174	199	27	
50	40	0.5 - 10	199 041 349	8.100	165	224	290	43	
63	50	0.5 - 10	199 041 350	8.300	165	244	290	43	



SYGEF® standard
Pressure relief valve type V 85
With fusion spigots metric

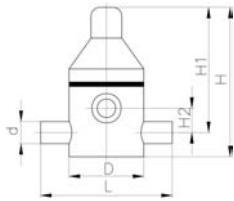

PF 3 58 458

d [mm]	DN [mm]	Pressure range [bar]	PTFE Code	kg	D [mm]	L [mm]	H [mm]	H1 [mm]	H2 [mm]	
75	65	1.0 - 6	199 041 898	13.000	180	284	295	250	70	



SYGEF® standard
Gauge guard type Z 700
With manometer 0-10 bar

E

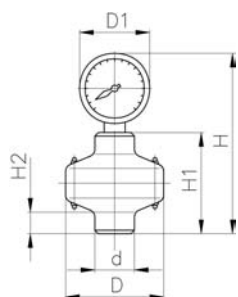

PF 3 58 458

d [mm]	G [inch]	PTFE Code	kg	D [mm]	D1 [mm]	H [mm]	H1 [mm]	H2 [mm]	
25	¼	199 041 004	0.320	72	63	129	71	15	
32	½	199 041 005	0.670	100	100	210	90	22	



SYGEF® standard
Gauge guard type Z 700
With manometer 0-6 bar

E

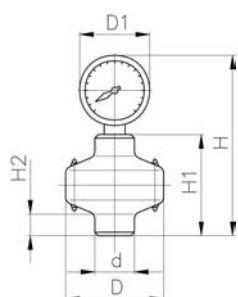

PF 3 58 458

d [mm]	G [inch]	PTFE Code	kg	D [mm]	D1 [mm]	H [mm]	H1 [mm]	H2 [mm]	
25	¼	199 041 296	0.320	72	63	129	71	15	
32	½	199 041 297	0.670	100	100	210	90	22	



SYGEF® standard Water jet suction pump type P 20

E

- DN 10-20: BSP parallel female thread
- DN 25-50: Fusion socket metric
- DN 65-80: Fusion spigot metric

d [mm]	DN [mm]	PN	FPM Code	kg	G [inch]	G1 [inch]	L [mm]	L1 [mm]	L2 [mm]	H [mm]	H1 [mm]
16	10	10	199 041 138	0.160	R 3/4	R 3/4		110	40		35
20	15	10	199 041 139	0.300	R 1	R 3/4		110	40		35
25	20	10	199 041 140	0.480	R 1 1/4	R 3/4		145	45		45
32	25	10	199 041 141	0.690	R 1 1/2	R 1 1/2	245	195		96	71
40	32	10	199 041 142	1.100	R 2	R 2	297	239		116	87
50	40	10	199 041 143	1.880	R 2 1/4	R 2 1/4	369	301		139	105
63	50	10	199 041 144	3.340	R 2 3/4	R 2 3/4	433	351		169	128
75	65	10	199 041 145	3.340	-	-	388				115
90	80	10	199 041 146	5.500	-	-	465				149

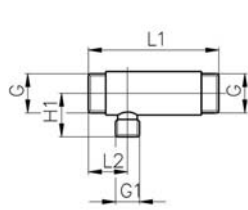

DN 10 - 20

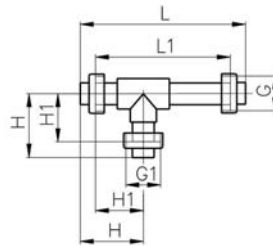

DN 25 - 50

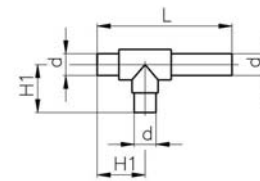

DN 65 - 80

PF 3 58 458



SYGEF® standard Ventilating valve type V 95 With fusion spigots metric

E

d [mm]	DN [mm]	FPM Code	kg	D [mm]	L [mm]	L1 [mm]
16	10	199 041 283	0.090	35	114	14
20	15	199 041 284	0.130	40	124	16
25	20	199 041 285	0.180	45	144	19
32	25	199 041 286	0.280	55	154	22
40	32	199 041 287	0.550	70	174	26
50	40	199 041 288	0.700	80	194	31
63	50	199 041 289	1.280	95	224	38
75	65	199 041 290	1.900	115	284	44
90	80	199 041 291	3.230	150	300	51

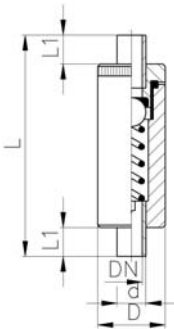

PF 3 58 458



SYGEF® standard Ventilating and bleed valve type V 91 With fusion spigots metric

E

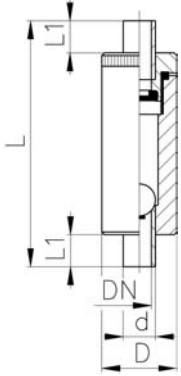

PF 3 58 458

d [mm]	DN [mm]	FPM Code	kg	D [mm]	L [mm]	L1 [mm]	
16	10	199 041 256	0.090	35	114	14	
20	15	199 041 257	0.130	40	124	16	
25	20	199 041 258	0.180	45	144	19	
32	25	199 041 259	0.270	55	154	22	
40	32	199 041 260	0.520	70	174	26	
50	40	199 041 261	0.660	80	194	31	
63	50	199 041 262	1.210	95	224	38	
75	65	199 041 263	1.770	115	284	44	
90	80	199 041 264	3.100	150	300	51	



SYGEF® standard Throttle valve type V 251 With fusion sockets metric

E

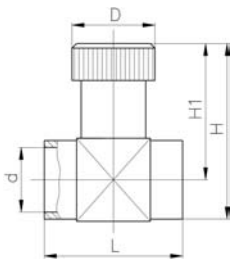

PF 3 58 458

d [mm]	DN [mm]	PN	FPM Code	kg	D [mm]	L [mm]	H [mm]	H1 [mm]	
16	10	10	199 041 231	0.150	29	47	57	45	
20	15	10	199 041 232	0.124	35	55	66	51	
25	20	10	199 041 233	0.100	40	66	80	63	
32	25	10	199 041 234	0.135	47	80	96	75	
40	32	10	199 041 235	-	56	100	111	86	
50	40	10	199 041 236	0.250	70	120	133	101	
63	50	10	199 041 237	1.240	88	146	158	118	

Variable area flow meters

Special version PVDF Float in PVDF (red) without magnet

- Limit contacts (min. / max.) and special scales on request

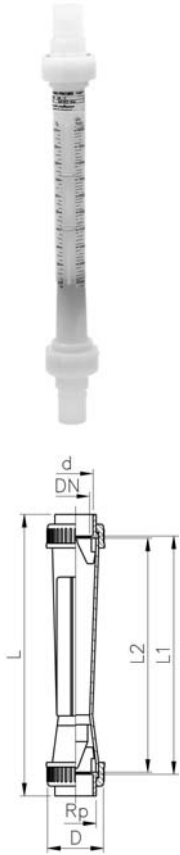











PF 3 48 227

Type	d [mm]	DN [mm]	Scale range [l/h]	Taper tube in PVDF O-rings in FPM fusion socket Code	Taper tube in PVDF O-rings in FPM IR fusion spigot Code	kg
SK 10	32	25	50 - 500	198 806 466	198 803 905	0.520
SK 11	32	25	100 - 1000	198 806 467	198 803 906	0.520
SK 20	50	40	200 - 2000	198 806 468	198 803 907	1.220
SK 21	50	40	300 - 3000	198 806 469	198 803 908	1.220
SK 30	63	50	600 - 6000	198 806 470	198 803 909	1.680
SK 31	63	50	1200 - 12000	198 806 471	198 803 910	1.680
SK 40	75	65	2000 - 20000	198 806 472	198 803 911	2.900
SK 41	75	65	3000 - 30000	198 806 473	198 803 912	2.900

Type	D [mm]	L [mm]	L (IR-SS) [mm]	L1 [mm]	L2 [mm]	Rp [inch]
SK 10	60	385	443	341	335	1
SK 11	60	385	443	341	335	1
SK 20	83	403	459	341	335	1 ½
SK 21	83	403	459	341	335	1 ½
SK 30	103	417	461	339	335	2
SK 31	103	417	461	339	335	2
SK 40	122	429	453	341	335	2 ½
SK 41	122	429	453	341	335	2 ½

SYGEF® Plus

		Page
	Pipes	211
	Fittings for Butt Fusion	212
	Unions for Butt Fusion	221
	Transition Fittings and Sanitary Adaptors	224
	Sanitary Adaptors	226
	Flange Adaptors, Flanges and Gaskets	229
	Diaphragm valves	234
	Diaphragm valves pneumatic	243
	Process control valves	278
	Variable area flow meters	281

SYGEF® Plus – Product Specification

Material	High Purity Polyvinylidene fluoride (PVDF HP)
Colour	Virgin material, translucent
Density	~1.78g/cm ³ (ISO 1183 / ASTM D 792)
Surface tension	30–35mJ/m ²
Linear expansion coefficient	0.12–0.18mm/mK (DIN 53752)
E-module (tensile strength)	2100N/mm ² (EN ISO 527/ASTM D 790)
Thermal conductivity	0.19W/mK (DIN 52612)
Surface resistivity	5 x 10 ¹⁴ Ωcm (IEC 60093)
Dimension	d 20 (½")–d 315 (12") in accordance to ISO 10931
Pressure rating	Pipes/fittings: PN 16 (d 20–d 225), PN 10 (d 90–d 315) Valves: separate specification
Temperature rating	from –20 °C to 140 °C (–4 °F–284 °F)
Production⁽¹⁾	Fittings/diaphragm valves: injection moulded Pipes: extruded Produced under clean room ISO 14644-1 Class 7 (U.S. Fed. Std. 209E Class 10'000) conditions. Subsequent assembling, quality inspection and cleaning is carried out using 18MΩ pure water under clean room ISO 14644-1 Class 5-6 (U.S. Fed. Std. 209E Class 100-1000) conditions.
Surface finish	Inner surface ≤ d 225 Ra ≤ 0.2µm (9µin) / > d 225 Ra ≤ 0.3µm (12µin) for injection moulded and extruded components
Marking	All components are embossed with a permanent identification during the production process to ensure full traceability. Lot No Material Dimension Pressure Rating
Testing and inspection (ISO 10931)	Inclusions Visual inspection Surface finish Dimension tolerance Pressure testing Periodic leachout per SEMI F40/F57
Approvals/conformance	ASME BPE FDA CFR 21 177.2510 USP 25 class VI (physiological non-toxic) SEMI F57
Welding technology	BCF® Plus, bead and crevice free fusion, size d 20 (½")–d 110 (4") IR® Plus, infrared fusion (DVS 2207-6), size d 20 (½")–d 315 (12")
Documentation⁽¹⁾	Certificate of Conformance with FDA, USP EN 10204 2.2 EN 10204 3.1b
Packing⁽²⁾	Pipes capped and each component double bagged in an specified inner bag and an outer bag under clean room ISO 14644-1 Class 6 (U.S. Fed. Std. 209E Class 1000) conditions.
Labeling	Brand Name Product Description Code Number Material Dimension CE-labeling
Main applications	Uses include delivery of ultrapure water in the semiconductor/electronic industry, pharmaceutical grade water (WFI/PW) and analytical DI water to highest purity requirements. A wide range of sanitisation methods is suitable such as Ozone, hot water or steam.

⁽¹⁾ on request

⁽²⁾ Excluding pressure regulating valves. Products are cleaned and double bagged after production assuring controlled process and highest product standards.

Pipes

75 48 12

Pipe, PN 16, PVDF-HP

J

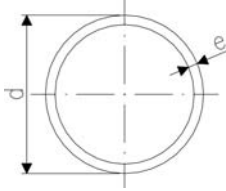

d [mm]	PN	Code	e [mm]	Weight [kg/m]	Length [m]
16	16	175 481 202	1.9	0.132	5.00
20	16	175 481 203	1.9	0.209	5.00
25	16	175 481 204	1.9	0.278	5.00
32	16	175 481 205	2.4	0.425	5.00
40	16	175 481 206	2.4	0.550	5.00
50	16	175 481 207	3.0	0.835	5.00
63	16	175 481 208	3.0	1.080	5.00
75	16	175 481 209	3.6	1.519	5.00
90	16	175 481 210	4.3	2.210	5.00
110	16	175 481 211	5.3	3.336	5.00
125	16	175 481 212	6.0	4.424	5.00
160	16	175 481 214	7.7	6.960	5.00
140	16	175 481 213	6.7	5.310	5.00
200	16	175 481 216	9.6	10.800	5.00
225	16	175 481 217	10.8	13.700	5.00

PF 2 37 202

75 48 16

Pipe, PN 10, PVDF-HP

J

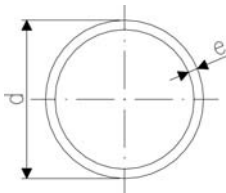

d [mm]	PN	Code	e [mm]	Weight [kg/m]	Length [m]
90	10	175 481 665	2.8	1.565	5.00
110	10	175 481 666	3.4	2.140	5.00
125	10	175 481 667	3.9	2.800	5.00
140	10	175 481 673	4.3	3.710	5.00
160	10	175 481 668	4.9	4.657	5.00
200	10	175 481 669	6.2	6.916	5.00
225	10	175 481 670	6.9	9.162	5.00
250	10	175 481 671	7.7	11.100	5.00
280	10	175 481 656	8.6	13.900	5.00
315	10	175 481 674	9.7	17.600	5.00

PF 2 37 202

Fittings for Butt Fusion

35 01 87

Bend 90°, PN 16, PVDF-HP

K

- * new model with compact design and optimized flow values

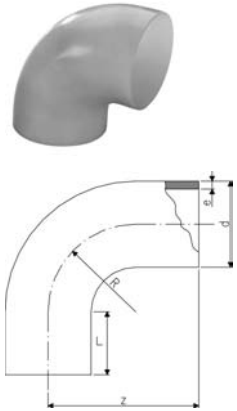

PF 2 37 249

d [mm]	PN	Code	kg	e [mm]	L [mm]	z [mm]	R [mm]
*20	16	735 018 731	0.015	1.9	23	38	15
*25	16	735 018 732	0.021	1.9	23	42	19
*32	16	735 018 733	0.035	2.4	22	46	24
*40	16	735 018 734	0.050	2.4	21	51	30
*50	16	735 018 735	0.087	3.0	21	58	37
*63	16	735 018 736	0.128	3.0	21	66	45
75	16	735 018 737	0.243	3.6	23	75	62
90	16	735 018 738	0.385	4.3	23	90	77
110	16	735 018 739	0.643	5.3	23	110	98
140	16	735 018 741	1.423	6.7	33	140	121
160	16	735 018 742	2.052	7.7	33	160	141
200	16	735 018 744	3.798	9.6	33	200	181
225	16	735 018 745	5.274	10.8	33	220	200

35 01 85

Bend 90°, PN 10, PVDF-HP

K

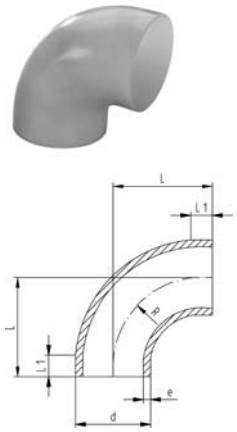

PF 2 37 249

d [mm]	PN	Code	kg	e [mm]	L [mm]	L1 [mm]	e1 [mm]	L2 [mm]
90	10	735 018 538	0.294	2.8	90	23		
110	10	735 018 539	0.578	3.4	110	23		
125	10	735 018 540	0.670	3.9	125	28		
140	10	735 018 541	0.970	4.3	140	33		
160	10	735 018 542	1.440	4.7	160	33		
200	10	735 018 544	2.730	6.2	200	33		
225	10	735 018 545	3.900	6.9	220	33		
250	10	735 018 546	8.040	7.7	254	48		
*280	10	735 018 547	11.200	8.6	283	48	17.2	10
*315	10	735 018 548	15.900	9.7	321	48	19.3	10

35 10 86

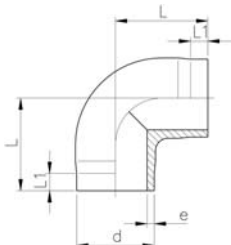
Elbow 90°, PN 16, PVDF-HP**K**

PF 2 37 249

d [mm]	PN	Code	kg	e [mm]	L [mm]	L1 [mm]
20	16	735 108 631	0.017	1.9	38	25
25	16	735 108 632	0.023	1.9	42	26
32	16	735 108 633	0.040	2.4	46	26
40	16	735 108 634	0.060	2.4	51	28
50	16	735 108 635	0.105	3.0	58	28
63	16	735 108 636	0.180	3.0	66	28

35 15 86

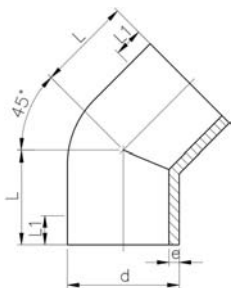
Elbow 45°, PN 16, PVDF-HP**K**

PF 2 37 249

d [mm]	PN	Code	kg	e [mm]	L [mm]	L1 [mm]
20	16	735 158 631	0.014	1.9	32	25
25	16	735 158 632	0.019	1.9	34	26
32	16	735 158 633	0.033	2.4	36	26
40	16	735 158 634	0.048	2.4	39	28
50	16	735 158 635	0.079	3.0	42	30
63	16	735 158 636	0.116	3.0	47	31
75	16	735 158 637	0.160	3.6	49	32
90	16	735 158 638	0.260	4.3	57	37
110	16	735 158 639	0.480	5.3	70	46
140	16	735 158 641	1.000	6.7	88	57
160	16	735 158 642	2.300	7.7	100	62
200	16	735 158 644	2.800	9.6	124	77
225	16	735 158 645	4.000	10.8	140	88

35 15 85

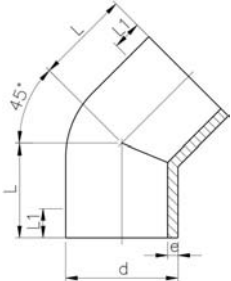
Elbow 45°, PN 10, PVDF-HP**K**

PF 2 37 249

d [mm]	PN	Code	kg	e [mm]	L [mm]	L1 [mm]
90	10	735 158 538	0.181	2.8	57	37
110	10	735 158 539	0.330	3.4	70	46
125	10	735 158 540	0.490	3.9	79	51
140	10	735 158 541	0.680	4.3	88	57
160	10	735 158 542	0.990	4.9	100	62
200	10	735 158 544	1.940	6.2	124	77
225	10	735 158 545	2.780	6.9	140	88

35 20 86

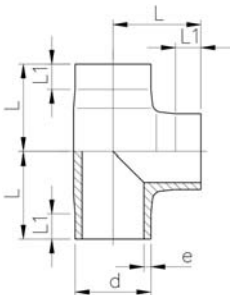
T 90° equal ; PN 16, PVDF-HP**K**

PF 2 37 249

d [mm]	PN	Code	kg	e [mm]	L [mm]	L1 [mm]
20	16	735 208 631	0.023	1.9	38	25
25	16	735 208 632	0.032	1.9	42	27
32	16	735 208 633	0.056	2.4	46	27
40	16	735 208 634	0.083	2.4	51	28
50	16	735 208 635	0.140	3.0	58	28
63	16	735 208 636	0.231	3.0	66	28
75	16	735 208 637	0.370	3.6	75	32
90	16	735 208 638	0.660	4.3	90	39
110	16	735 208 639	1.210	5.3	110	48
140	16	735 208 641	2.600	6.7	140	62
160	16	735 208 642	5.200	7.7	160	71
200	16	735 208 644	6.630	9.6	200	80
225	16	735 208 645	9.120	10.8	220	86

35 20 85

T 90° equal, PN 10, PVDF-HP

K

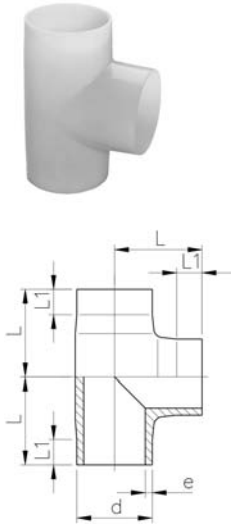

PF 2 37 249

d [mm]	PN	Code	kg	e [mm]	L [mm]	L1 [mm]
90	10	735 208 538	0.397	2.8	90	39
110	10	735 208 539	0.714	3.4	110	48
125	10	735 208 540	1.280	3.9	125	56
140	10	735 208 541	1.780	4.3	140	62
160	10	735 208 542	2.570	4.9	160	71
200	10	735 208 544	4.297	6.2	200	80
225	10	735 208 545	6.800	6.9	220	86
250	10	735 208 546	9.281	7.7	223	61
280	10	735 208 547	13.608	8.6	256	74
315	10	735 208 548	18.128	9.7	274	74

35 20 89 / 35 20 86 T 90° reduced; PN16, PVDF-HP

K

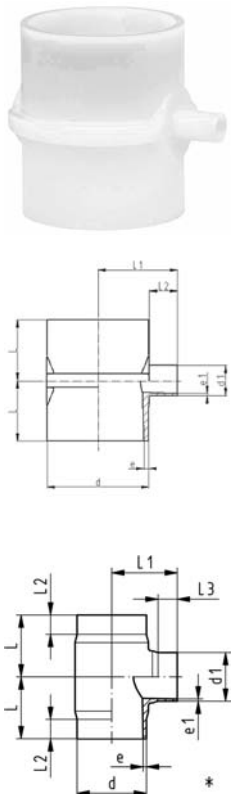

PF 2 37 425

d - d1 [mm]	PN	Code	kg	e [mm]	e1 [mm]	L [mm]	L1 [mm]	L2 [mm]	L3 [mm]
63 - 20	16	735 208 956	0.213	3.0	1.9	60	67	25	35
63 - 25	16	735 208 957	0.214	3.0	1.9	60	66	25	34
63 - 32	16	735 208 958	0.220	3.0	2.4	60	67	25	25
63 - 40	16	735 208 959	0.217	3.0	2.4	60	66	25	26
75 - 20	16	735 208 961	0.306	3.6	1.9	65	69	25	31
75 - 25	16	735 208 962	0.308	3.6	1.9	65	72	25	34
75 - 32	16	735 208 963	0.308	3.6	2.4	65	69	25	31
75 - 40	16	735 208 964	0.312	3.6	2.4	65	72	25	26
75 - 50	16	735 208 965	0.309	3.6	3.0	65	69	25	26
90 - 20	16	735 208 967	0.403	4.3	1.9	65	76	25	31
90 - 25	16	735 208 968	0.405	4.3	1.9	65	79	25	34
90 - 32	16	735 208 969	0.405	4.3	2.4	65	76	25	31
90 - 40	16	735 208 970	0.409	4.3	2.4	65	79	25	26
90 - 50	16	735 208 971	0.406	4.3	3.0	65	76	25	26
*90 - 63	16	735 208 972	0.540	4.3	3.0	80	85	25	25
110 - 20	16	735 208 974	0.568	5.3	1.9	65	86	25	31
110 - 25	16	735 208 975	0.570	5.3	1.9	65	89	25	34
110 - 32	16	735 208 976	0.570	5.3	2.4	65	86	25	31
110 - 40	16	735 208 977	0.572	5.3	2.4	65	89	25	26
110 - 50	16	735 208 978	0.568	5.3	3.0	65	86	25	26
*110 - 63	16	735 208 979	0.853	5.3	3.0	90	95	30	25
*110 - 75	16	735 208 980	0.863	5.3	3.0	90	95	30	25
*110 - 90	16	735 208 981	0.870	5.3	4.3	90	95	30	25
*160 - 90	16	735 208 687	3.200	7.7	4.3	155	130	60	25
*160 - 110	16	735 208 686	3.300	7.7	5.3	155	130	60	25
*225 - 90	16	735 208 695	6.000	10.8	4.3	155	160	60	25
*225 - 110	16	735 208 694	6.100	10.8	5.3	155	160	60	25

35 20 85

T 90° reduced; PN 10, PVDF-HP

K

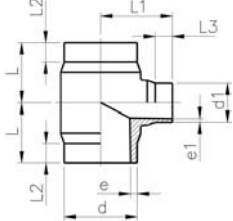

PF 2 37 425

d - d1 [mm]	PN [bar]	Code	kg	e [mm]	e1 [mm]	L [mm]	L1 [mm]	L2 [mm]	L3 [mm]
160 - 90	10 / 16	735 208 587	2.300	4.9	4.3	155	130	60	25
160 - 110	10 / 16	735 208 586	2.300	4.9	5.3	155	130	60	25
225 - 90	10 / 16	735 208 595	4.400	6.9	4.3	155	160	60	25
225 - 110	10 / 16	735 208 594	4.400	6.9	5.3	155	160	60	25

35 91 86

Restraint Fitting, PN 16, PVDF-HP

K

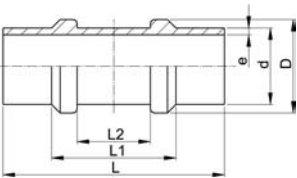

PF 2 37 249

d [mm]	PN	Code	kg	D [mm]	e [mm]	L [mm]	L1 [mm]	L2 [mm]
20	16	735 918 656	0.027	28	1.9	100	53	32
25	16	735 918 657	0.036	33	1.9	100	53	32
32	16	735 918 658	0.054	40	2.4	100	53	32
40	16	735 918 659	0.067	48	2.4	100	53	32
50	16	735 918 660	0.100	58	3.0	100	53	32
63	16	735 918 661	0.131	71	3.0	105	53	32
75	16	735 918 662	0.252	87	3.6	125	70	40
90	16	735 918 663	0.353	105	4.3	125	70	40
110	16	735 918 664	0.516	127	5.3	125	70	40

35 91 88

Instrument Installation Fitting, PN16, PVDF-HP

K

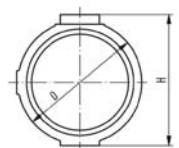
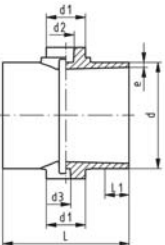

PF 2 37 425

Model:

- Suitable for hole diameters from 1/4 - 3/4
- Injection-moulded version

Note:

- Hole needs to be milled, HAND HELD DRILLING MUST NOT BE DONE

d [mm]	PN	Code	kg	D [mm]	e [mm]	d1 [mm]	d2 [mm]	H [mm]	L [mm]	L1 [mm]
63	16	735 918 811	0.235	85	3.0	40	17	89	120	25
75	16	735 918 812	0.326	96	3.6	40	17	101	130	25
90	16	735 918 813	0.418	110	4.3	40	17	116	130	25
110	16	735 918 814	0.561	127	5.3	40	17	136	130	25

35 91 86

Instrument Installation Fitting, PN 16, PVDF-HP

K



Model:

- Suitable for hole diameters from 1/8 - 3/4
- Machined version

Note:

- Hole needs to be milled, HAND HELD DRILLING MUST NOT BE DONE

* no stock item

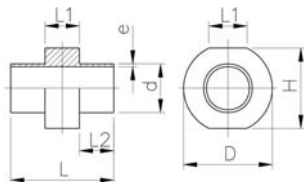

PF 2 37 425

d [mm]	PN	Code	kg	D [mm]	e [mm]	H [mm]	L [mm]	L1 [mm]	L2 [mm]
*63	16	735 918 611	0.495	105	3.0	97	100	40	27
*75	16	735 918 612	0.554	115	3.6	108	90	40	22
*90	16	735 918 613	0.649	128	4.3	121	90	40	22
*110	16	735 918 614	0.778	145	5.3	139	90	40	22
*125	16	735 918 615	1.007	162	6.0	157	100	40	27
*140	16	735 918 616	1.185	176	6.7	171	110	40	32
*160	16	735 918 617	1.405	194	7.7	190	110	40	32
*200	16	735 918 619	1.871	231	9.6	228	110	40	32
*225	16	735 918 620	2.284	254	10.8	251	110	40	32

35 91 85

Instrument Installation Fittings ; PN 10, PVDF-HP

K



Model:

- Suitable for hole diameters from 1/8 - 3/4
- Machined version

Note:

- Hole needs to be milled, HAND HELD DRILLING MUST NOT BE DONE

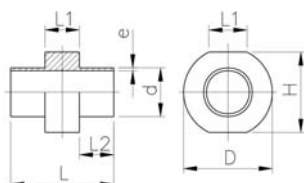

PF 2 37 425

d [mm]	PN	Code	kg	D [mm]	e [mm]	H [mm]	L [mm]	L1 [mm]	L2 [mm]
125	10	735 918 565	0.858	162	3.9	157	100	40	27
140	10	735 918 566	1.003	176	4.4	171	110	40	32
160	10	735 918 567	1.151	194	4.9	190	110	40	32
200	10	735 918 569	1.486	231	6.2	228	110	40	32
225	10	735 918 570	3.151	254	7.0	251	110	40	32

SYGEF® Standard Sensor Connection Tee

The maximal solution
for a minimal dead leg



Your benefit with the Sensor Connection Tee:

- Easier cleaning (CIP)
- Minimal Biofilm building up
- Reduced installation costs
- Compact design
- Reliable sensor connection
- Fulfills FDA and USP class VI

All available standards:

- ISO 1127
- DIN 32676
- ASME BPE
- MM
- 3A
- ISO 2852
- BS 4825 Metric & Inch
- DIN 3017
- JIS G3447
- SYGEF-Plus

The SCT at a glance:

- Main line sizes d20 to d110 compatible with IR-Plus® & BCF®Plus fusion
- PN16 welding dimension (PN10 for d90 & d110 also available)
- Clamp connection up from d20 to d75 depending on main line dimension
- Fully customised solution, to suit your application

→ Please contact GF for further technical information

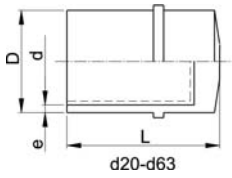

Caps, PVDF-HP

K

d [mm]	PN	Code	kg	e [mm]	L [mm]
20	16	735 991 651	0.020	1.9	47
25	16	735 991 652	0.028	1.9	48
32	16	735 991 653	0.050	2.4	52
40	16	735 991 654	0.068	2.4	59
50	16	735 991 655	0.107	3.0	64
63	16	735 991 656	0.165	3.0	69
75	16	735 991 657	0.283	3.6	40
90	16	735 991 658	0.509	4.3	40
110	16	735 991 659	0.812	5.3	40
160	10	735 991 661	1.046	4.9	50
200	10	735 991 662	1.637	6.2	50
225	10	735 991 663	2.072	6.9	50

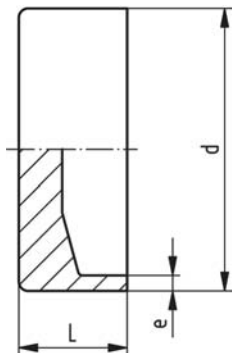

PF 2 65 460

Reducing Bush, eccentric, PN 16, PVDF-HP

K

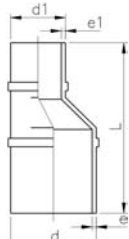

PF 2 65 433

d - d1 [mm]	Code	kg	e [mm]	e1 [mm]	L [mm]
25 - 20	735 938 737	0.020	1.9	1.9	80
32 - 20	735 938 742	0.027	2.4	1.9	80
32 - 25	735 938 741	0.028	2.4	1.9	80
40 - 20	735 938 748	0.041	2.4	1.9	100
40 - 25	735 938 747	0.042	2.4	1.9	100
40 - 32	735 938 746	0.049	2.4	2.4	100
50 - 32	735 938 753	0.066	3.0	2.4	100
50 - 40	735 938 752	0.069	3.0	2.4	100
63 - 32	735 938 760	0.083	3.0	2.4	100
63 - 40	735 938 759	0.084	3.0	2.4	100
63 - 50	735 938 758	0.096	3.0	3.0	100

35 90 86

Reducer, PN 16, PVDF-HP

K

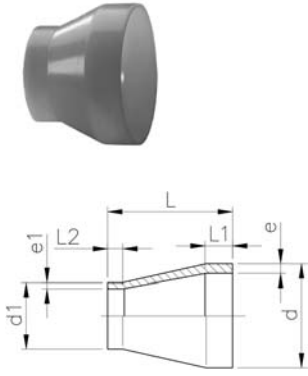

d - d1 [mm]	PN	Code	kg	e [mm]	e1 [mm]	L [mm]	L1 [mm]	L2 [mm]
25 - 20	16	735 908 600	0.012	1.9	1.9	50	22	22
32 - 20	16	735 908 602	0.017	2.4	1.9	50	22	22
32 - 25	16	735 908 601	0.018	2.4	1.9	50	22	22
40 - 20	16	735 908 605	0.024	2.4	1.9	58	22	24
40 - 25	16	735 908 604	0.025	2.4	1.9	55	22	24
40 - 32	16	735 908 603	0.029	2.4	2.4	55	22	24
50 - 25	16	735 908 608	0.031	3.0	1.9	60	22	25
50 - 32	16	735 908 607	0.038	3.0	2.4	60	22	25
50 - 40	16	735 908 606	0.040	3.0	2.4	60	22	25
63 - 32	16	735 908 611	0.050	3.0	2.4	65	22	25
63 - 40	16	735 908 610	0.052	3.0	2.4	65	22	25
63 - 50	16	735 908 609	0.060	3.0	3.0	65	22	25
75 - 40	16	735 908 614	0.069	3.6	2.4	68	24	25
75 - 50	16	735 908 613	0.078	3.6	3.0	65	24	25
75 - 63	16	735 908 612	0.080	3.6	3.0	65	24	25
90 - 63	16	735 908 616	0.120	4.3	3.0	75	25	30
90 - 75	16	735 908 615	0.130	4.3	3.6	75	25	35
110 - 63	16	735 908 619	0.225	5.3	3.0	90	30	30
110 - 75	16	735 908 618	0.220	5.3	3.6	90	30	35
110 - 90	16	735 908 617	0.230	5.3	4.3	90	30	35
140 - 110	16	735 908 621	0.450	6.7	5.3	110	40	40
160 - 110	16	735 908 623	1.000	7.7	5.3	120	40	40
160 - 140	16	735 908 622	0.660	7.7	6.7	120	40	40
200 - 160	16	735 908 624	1.340	9.6	7.7	145	40	35
225 - 110	16	735 908 625	1.540	10.8	5.3	160	55	40
225 - 160	16	735 908 626	1.730	10.8	7.7	160	55	28
225 - 200	16	735 908 627	1.980	10.8	9.6	160	55	50

PF 2 37 249

35 90 85

Reducer, PN 10, PVDF-HP

K

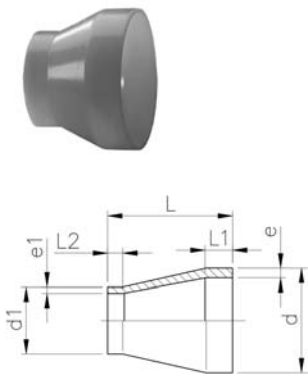

d - d1 [mm]	PN [bar]	Code	kg	e [mm]	e1 [mm]	L [mm]	L1 [mm]	L2 [mm]
90 - 63	10 / 16	735 908 511	0.102	2.8	3.0	75	25	30
110 - 63	10 / 16	735 908 513	0.164	3.4	3.0	90	30	30
110 - 90	10 / 10	735 908 515	0.167	3.4	2.8	90	30	35
125 - 110	10 / 16	735 908 500	0.270	3.9	5.3	100	35	40
140 - 110	10 / 16	735 908 502	0.385	4.3	5.3	110	40	40
140 - 125	10 / 10	735 908 501	0.340	4.3	3.9	110	40	40
160 - 110	10 / 10	735 908 521	0.449	4.9	3.4	120	40	40
160 - 110	10 / 16	735 908 504	0.425	4.9	5.3	120	40	40
160 - 140	10 / 10	735 908 503	0.460	4.9	4.3	120	40	40
200 - 160	10 / 10	735 908 505	0.830	6.2	4.9	145	50	40
225 - 110	10 / 10	735 908 526	1.120	6.9	3.4	160	55	35
225 - 110	10 / 16	735 908 506	0.940	6.9	5.3	160	55	35
225 - 160	10 / 10	735 908 507	1.140	6.9	4.9	160	55	40
225 - 200	10 / 10	735 908 508	1.200	6.9	6.2	160	55	50
250 - 225	10 / 10	735 908 531	1.871	7.7	6.9	182	60	55
280 - 225	10 / 10	735 908 532	2.518	8.6	6.9	206	70	55
315 - 225	10 / 10	735 908 533	3.456	9.7	6.9	231	80	55

PF 2 37 249

Unions for Butt Fusion

35 51 87

Union (FPM white), PN 16, PVDF-HP

K

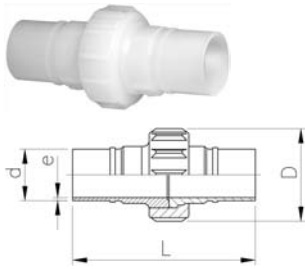

Model:

- FDA compliant
- supplied with sealing
- d75, d90 and d110 with buttress shaped thread
- * version without BCF collar (won't be replaced)

- Please see installation instruction

Note:

- Products, except d75-110, will be replaced in 1. quarter 2007

d [mm]	PN	Code	kg	D [mm]	L [mm]	e [mm]
20	16	735 518 706	0.093	45	137	1.9
25	16	735 518 707	0.130	57	136	1.9
32	16	735 518 708	0.180	62	138	2.4
40	16	735 518 709	0.300	75	176	2.4
50	16	735 518 710	0.419	84	178	3.0
63	16	735 518 711	0.637	101	187	3.0
*75	16	735 528 637	0.740	133	131	3.6
*90	16	735 528 638	0.730	133	131	4.3
*110	16	735 528 639	1.020	155	131	5.3

PF 2 65 434

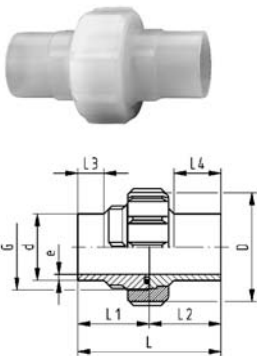

Union (FPM white), PN 16, PVDF-HP

Model:

- FDA compliant
- supplied with sealing
- d75, d90 and d110 with buttress shaped thread

- Please see installation instruction

Note:

- market launch in 1. quarter 2007

d [mm]	PN	Code	kg	e [mm]	D [mm]	L [mm]
20	16	735 528 626		1.9	45	107
25	16	735 528 627		1.9	55	112
32	16	735 528 628		2.4	62	119
40	16	735 528 629		2.4	75	125
50	16	735 528 630		3.0	84	130
63	16	735 528 631		3.0	101	136
*75	16	735 528 637	0.740	3.6	133	131
*90	16	735 528 638	0.730	4.3	133	131
*110	16	735 528 639	1.020	5.3	155	131

PF 2 65 434

Blanking Union End

d [mm]	d [inch]	PN	DN [mm]	Code	SP	kg	A [mm]	B [mm]	C [inch]	D [mm]
20		232	0	175 482 101	-	0.007				
25		232	0	175 482 102	-	0.015	1	1	1	0
32		232	0	175 482 103	-	0.025	2	1	1	0
50		232	0	175 482 105	-	0.060				
63		232	0	175 482 106	-	0.110				

24 60 06

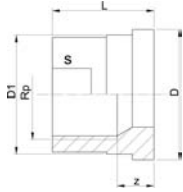
Union Ends, Stainless Steel 1.4404 (316L)**Rp****A**

PF 2 30 153

Model:

- Parallel female thread Rp

Rp [inch]	PN	Code	SP	kg	z [mm]	D [mm]	D1 [mm]	L [mm]	s [mm]
3/8	16	724 600 655	-	0.030	9	24	22	19	19
1/2	16	724 600 656	-	0.060	11	30	28	24	24
3/4	16	724 600 657	-	0.100	11	39	36	26	29
1	16	724 600 658	-	0.140	12	45	42	29	36
1 1/4	16	724 600 659	-	0.230	14	57	53	33	45
1 1/2	16	724 600 660	-	0.320	15	63	59	34	54
2	16	724 600 661	-	0.450	15	78	74	39	63

24 60 07

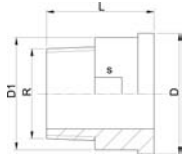
Union Ends, Stainless Steel 1.4404 (316L)**R****A**

PF 2 30 153

Model:

- Taper male thread R

R [inch]	PN	Code	SP	kg	D [mm]	D1 [mm]	L [mm]	s [mm]
3/8	16	724 600 705	-	0.050	24	22	30	19
1/2	16	724 600 706	-	0.090	30	28	34	24
3/4	16	724 600 707	-	0.120	39	36	36	32
1	16	724 600 708	-	0.190	45	42	40	37
1 1/4	16	724 600 709	-	0.350	57	53	46	48
1 1/2	16	724 600 710	-	0.400	63	59	48	54
2	16	724 600 711	-	0.660	78	74	55	69

24 60 55

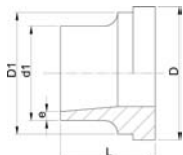
Union Ends, Stainless Steel 1.4404 (316L)**Welding End****A**

PF 2 30 153

d [mm]	d1 [mm]	PN	Code	SP	kg	D [mm]	D1 [mm]	L [mm]	e [mm]
16	17	16	724 605 505	-	0.030	24	22	18	1.6
20	21	16	724 605 506	-	0.050	30	28	22	2.0
25	26	16	724 605 507	-	0.080	39	36	23	2.0
32	33	16	724 605 508	-	0.110	45	42	26	2.0
40	42	16	724 605 509	-	0.190	57	53	26	2.0
50	48	16	724 605 510	-	0.220	63	59	28	2.0
63	60	16	724 605 511	-	0.370	78	74	32	2.6

35 69 04

Union nut, PN16, PVDF-Standard**J**

- d75, d90 and d110 with buttress shaped thread

Note:

- For the dimensions d75-110 please see instructions for the installation

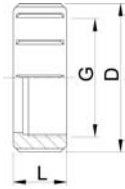

PF 2 35 191

Socket Fusion d [mm]	Butt Fusion d [mm]	PN	Code	kg	D [mm]	G [inch]	L [mm]
16	16	16	735 690 405	0.013	35	3/4	21
20	20	16	735 690 406	0.023	45	1	22
25	25	16	735 690 407	0.047	55	1 1/4	24
32	32	16	735 690 408	0.048	62	1 1/2	26
40	40	16	735 690 409	0.097	75	2	29
50	50	16	735 690 410	0.146	84	2 1/4	33
63	63	16	735 690 411	0.244	101	2 3/4	35
75	75-90	16	735 690 422	0.290	133	S 107,5x3,6	40
90	110	16	735 690 423	0.420	155	S 127,5x3,6	42
110	-	16	735 690 424	0.650	185	S 152,5x3,6	47

24 69 01

Union nut stainless steel 1.4404 (316L)**A**

* Octagon union nut

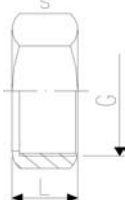

PF 2 30 153

d [mm]	PN	Code	SP	kg	L [mm]	G [inch]	s [mm]
16	16	724 690 105	-	0.060	19	¾	32
20	16	724 690 106	-	0.110	21	1	41
25	16	724 690 107	-	0.100	23	1 ¼	46
32	16	724 690 108	-	0.170	24	1 ½	55
*40	16	724 690 109	-	0.240	27	2	68
*50	16	724 690 110	-	0.300	31	2 ¼	74
*63	16	724 690 111	-	0.390	35	2 ¾	88

49 41 10

O-Ring, FPM white

- For SYGEF® Plus Union and diaphragm valve SYGEF® Plus type 314

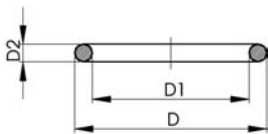

PF 2 65 434

d [mm]	PN	Code	kg	D [mm]	D1 [mm]	D2 [mm]
20	16	749 411 005	0.002	20.7	15.5	2.6
25	16	749 411 006	0.002	27.2	20.2	3.5
32	16	749 411 120	0.002	33.6	26.6	3.6
40	16	749 411 062	0.003	41.6	34.5	3.6
50	16	749 411 172	0.003	51.1	44.0	3.5
63	16	749 411 054	0.005	63.0	55.0	4.0
75	16	749 411 014	0.012	75.5	81.9	5.3
90	16	749 411 015	0.015	90.0	101.0	5.3
110	16	749 411 016	0.031	110.0	120.0	7.0

Transition Fittings and Sanitary Adaptors

35 91 07

Adaptor Nipple, male thread - R, PN 16, PVDF-HP

Model:

- With taper male thread
- Connection to plastic thread only
- Do not use thread sealing pastes that are harmful to PVDF
- Avoid stresses when installing and large changes in temperature

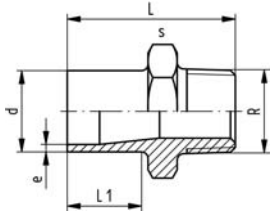

PF 2 35 421

d [mm]	R [inch]	PN	Code	kg	e [mm]	L [mm]	s [mm]	L1 [mm]
20	1/2	16	735 910 706	0.020	1.9	53	32	28
25	3/4	16	735 910 707	0.021	1.9	55	36	28
32	1	16	735 910 708	0.034	2.4	57	46	28
40	1 1/4	16	735 910 709	0.058	2.4	60	55	28
50	1 1/2	16	735 910 710	0.087	3.0	63	65	28
63	2	16	735 910 711	0.118	3.0	69	75	29

35 91 43

Adaptor Nipple, male thread - NPT, PN 16, PVDF-HP

Model:

- With taper male thread
- Connection to plastic thread only
- Do not use thread sealing pastes that are harmful to PVDF
- Avoid stresses when installing and large changes in temperature

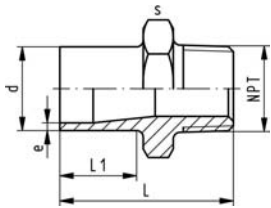

PF 2 65 460

d [mm]	NPT [inch]	PN	Code	kg	e [mm]	L [mm]	s [mm]	L1 [mm]
20	1/2	16	735 914 306	0.016	1.9	53	32	28
25	3/4	16	735 914 307	0.021	1.9	55	36	28
32	1	16	735 914 308	0.035	2.4	57	46	28
40	1 1/4	16	735 914 309	0.057	2.4	60	55	28
50	1 1/2	16	735 914 310	0.085	3.0	63	65	28
63	2	16	735 914 311	0.119	3.0	69	75	29

35 91 07

Adaptor Socket, female thread - Rp, PN 16, PVDF-HP

Model:

- With parallel female thread Rp
- Connection to plastic thread only
- Do not use thread sealing pastes that are harmful to PVDF
- Avoid stresses when installing and large changes in temperature

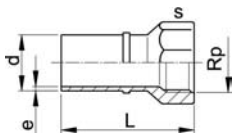

PF 2 65 434

d [mm]	Rp [inch]	PN	Code	kg	e [mm]	L [mm]	s [mm]	L1 [mm]
20	1/2	16	735 910 736	0.020	1.9	58	30	28
25	3/4	16	735 910 737	0.060	1.9	60	35	28
32	1	16	735 910 738	0.090	2.4	65	45	28
40	1 1/4	16	735 910 739	0.130	2.4	85	54	28
50	1 1/2	16	735 910 740	0.170	3.0	85	60	28
63	2	10	735 910 741	0.250	3.0	93	76	29

35 91 44

Adaptor Socket, female thread - NPT, PN 16, PVDF-HP**Model:**

- Connection to plastic or metal
- Do not use thread sealing pastes that are harmful to PVDF
- Avoid stresses when installing and large changes in temperature

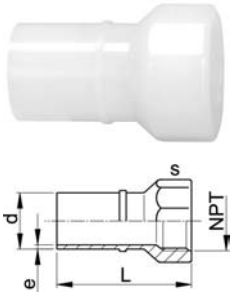

PF 2 65 460

d [mm]	NPT [inch]	PN	Code	kg	e [mm]	L [mm]	s [mm]
25	½	16	735 914 406	0.021	1.9	58	30
25	¾	16	735 914 407	0.028	1.9	60	35
32	1	16	735 914 408	0.049	2.4	65	45
40	1 ¼	16	735 914 409	0.084	2.4	85	54
50	1 ½	16	735 914 410	0.110	3.0	85	60
63	2	10	735 914 411	0.173	3.0	93	76

**Hose Adapter, PN 16, PVDF-HP****K****Model:**

- With butt fusion spigot

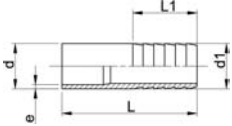

PF 2 37 423

d - d1 [mm]	PN	e [mm]	L [mm]	L1 [mm]	Code	kg
20 - 20	16	1.9	64	27	735 968 731	0.001
25 - 25	16	1.9	75	36	735 968 732	0.001
32 - 32	16	2.4	82	36	735 968 733	0.001
40 - 40	16	2.4	84	42	735 968 734	0.001
50 - 50	16	3.0	90	48	735 968 735	0.150
63 - 60	16	3.0	100	50	735 968 736	0.001

**Flare Transition Fitting, PN 16, PVDF-HP****K**

d [mm]	tube size [inch]	PN	Code	kg	D [mm]	e [mm]	L [mm]	L1 [mm]	L2 [mm]
20	¼	16	735 991 430	0.017	19	1.9	74	43	31
20	⅜	16	735 991 431	0.020	22	1.9	77	46	31
20	½	16	735 991 432	0.025	25	1.9	79	48	31
20	¾	16	735 991 433	0.017	34	1.9	83	52	31
25	¼	16	735 991 435	0.020	19	1.9	74	43	31
25	⅜	16	735 991 436	0.022	22	1.9	77	46	31
25	½	16	735 991 437	0.027	25	1.9	79	48	31
25	¾	16	735 991 438	0.045	34	1.9	83	52	31
25	1	16	735 991 439	0.014	37	1.9	84	58	31
32	½	16	735 991 442	0.034	25	2.4	79	48	31
32	¾	16	735 991 443	0.050	34	2.4	83	52	31
32	1	16	735 991 444	0.035	37	2.4	89	58	31

PF 2 65 434

Sanitary Adaptors

Sanitary Adaptor, PN 16, PVDF-HP, with stainless reinforcement ferrule ISO 1127

K

* Model without chamfer

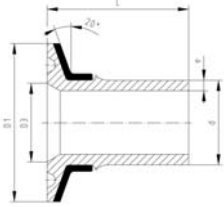

PF 2 65 456

d [mm]	DN [mm]	PN	Code	kg	e [mm]	D1 [mm]	D3 [mm]	L [mm]
20	15	16	735 598 006	0.032	1.9	50	18	49
25	20	16	735 598 008	0.042	1.9	50	24	55
25	25	16	735 598 009	0.041	1.9	50	30	55
32	25	16	735 598 010	0.045	2.4	50	30	57
40	32	16	735 598 014	0.073	2.4	64	35	67
*50	40	16	735 598 016	0.083	3.0	64	44	68
*63	50	16	735 598 018	0.107	3.0	78	56	71

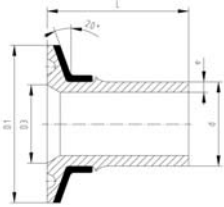

PF 2 65 456

Sanitary Adaptor, PN 16, PVDF-HP, with stainless reinforcement ferrule DIN 32676

K

* Model without chamfer

d [mm]	DN [mm]	PN	Code	kg	e [mm]	D1 [mm]	D3 [mm]	L [mm]
*20	15	16	735 598 056	0.020	1.9	34	16	49
20	20	16	735 598 057	0.020	1.9	34	20	49
25	25	16	735 598 059	0.042	1.9	50	26	55
32	32	16	735 598 062	0.045	2.4	50	32	57
40	40	16	735 598 065	0.047	2.4	50	38	67
50	50	16	735 598 067	0.081	3.0	64	50	68

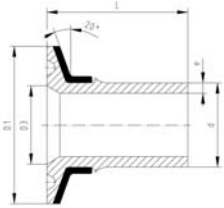

PF 2 65 456

Sanitary Adaptor, PN 16, PVDF-HP, with stainless reinforcement ferrule BS 4825 (inch)

K

* Model without chamfer

d [mm]	Inch	PN	Code	kg	e [mm]	D1 [mm]	D3 [mm]	L [mm]
20	3/4	16	735 598 157	0.040	1.9	50	22	49
*25	1	16	735 598 159	0.042	1.9	50	22	49
32	1 1/2	16	735 598 163	0.044	2.4	50	35	57
40	1 1/2	16	735 598 165	0.047	2.4	50	35	67
50	2	16	735 598 167	0.082	3.0	64	48	68
63	2 1/2	16	735 598 169	0.107	3.0	78	60	71



Sanitary Adaptor, PN 16, PVDF-HP, with stainless reinforcement ferrule 3A Standard

K

¹ Model without stainless reinforcement

* Model without chamfer

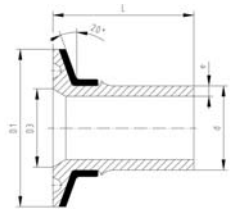

PF 2 65 456

d [mm]	Inch	PN	Code	kg	e [mm]	D1 [mm]	D3 [mm]	L [mm]
¹ *20	3/4	16	735 598 207	0.011	1.9	25	16	49
*25	1	16	735 598 209	0.042	1.9	50	22	49
32	1 1/2	16	735 598 213	0.044	2.4	50	35	57
40	1 1/2	16	735 598 215	0.047	2.4	50	35	67
50	2	16	735 598 217	0.082	3.0	64	48	68
63	2 1/2	16	735 598 219	0.107	3.0	78	60	71



Sanitary Adaptor, PN 16, PVDF-HP, with stainless reinforcement DIN 3017

K

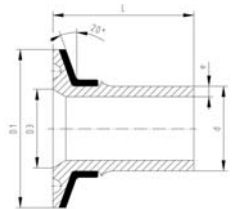

PF 2 65 456

d [mm]	DN [mm]	PN	Code	kg	e [mm]	D1 [mm]	D3 [mm]	L [mm]
25	25	16	735 598 259	0.042	1.9	50	23	55
32	32	16	735 598 262	0.042	2.4	50	31	57
40	40	16	735 598 265	0.047	2.4	50	36	67
50	50	16	735 598 267	0.081	3.0	64	49	68
63	65	16	735 598 269	0.107	3.0	78	60	71



Sanitary Adaptor, PN 16, PVDF-HP, with stainless reinforcement ISO 2852

K

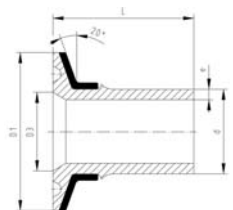

PF 2 65 456

d [mm]	DN [mm]	PN	Code	kg	e [mm]	D1 [mm]	D3 [mm]	L [mm]
25	25	16	735 598 309	0.042	1.9	50	23	55
32	32	16	735 598 312	0.045	2.4	50	31	57
40	40	16	735 598 315	0.047	2.4	50	36	67
50	50	16	735 598 317	0.081	3.0	64	49	68
63	65	16	735 598 319	0.107	3.0	78	60	71



Sanitary Adaptor, PN 16, PVDF-HP, with stainless reinforcement ASME BPE

K

¹ Model without stainless reinforcement

* Model without chamfer

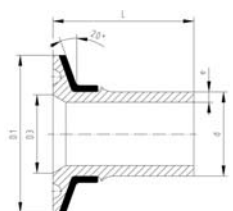

PF 2 65 456

d [mm]	Inch	PN	Code	kg	e [mm]	D1 [mm]	D3 [mm]	L [mm]
¹ *20	3/4	16	735 598 357	0.011	1.9	25	16	49
25	1	16	735 598 359	0.042	1.9	50	22	55
32	1 1/2	16	735 598 362	0.044	2.4	50	35	57
40	1 1/2	16	735 598 365	0.047	2.4	50	35	57
50	2	16	735 598 367	0.082	3.0	64	48	68
63	2 1/2	16	735 598 369	0.107	3.0	78	60	71



Sanitary Adaptor, PN 16, PVDF-HP, with stainless reinforcement JIS G3447

K

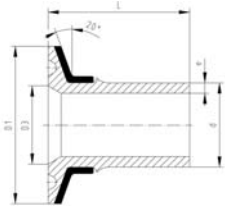

PF 2 65 456

d [mm]	DN [mm]	PN	Code	kg	e [mm]	D1 [mm]	D3 [mm]	L [mm]
20	15	16	735 598 406	0.020	1.9	34	18	49
25	20	16	735 598 408	0.042	1.9	50	23	55
32	25	16	735 598 410	0.045	2.4	50	29	57
40	32	16	735 598 414	0.047	2.4	50	36	67
50	40	16	735 598 416	0.082	3.0	64	48	68
63	50	16	735 598 418	0.107	3.0	78	60	71



Sanitary Adaptor, PN 16, PVDF-HP, with stainless reinforcement ferrule for Mebrane Manometer

K

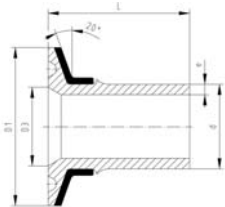

PF 2 65 456

d [mm]	DN [mm]	PN	Code	kg	e [mm]	D1 [mm]	D3 [mm]	L [mm]
20	15	16	735 598 506	0.038	1.9	50	34	49
25	20	16	735 598 508	0.041	1.9	50	34	55
32	25	16	735 598 510	0.045	2.4	50	34	57



Sanitary Adaptor, PN 16, PVDF-HP, with stainless reinforcement for PVDF-PVDF connection

K

Model:

- without chamfer for completely evacuation even in horizontal installation

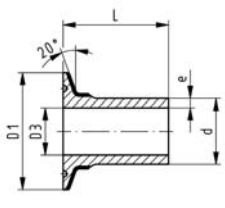

PF 2 65 456

d [mm]	PN	Code	kg	e [mm]	D1 [mm]	D3 [mm]	L [mm]
20	16	735 598 806	0.041	1.9	50.5	16.7	49
25	16	735 598 807	0.044	1.9	50.5	19.9	55
32	16	735 598 808	0.049	2.4	50.5	25.6	57
40	16	735 598 809	0.079	2.4	64.0	33.4	67
50	16	735 598 810	0.090	3.0	64.0	42.2	68
63	16	735 598 811	0.118	3.0	77.5	55.1	71

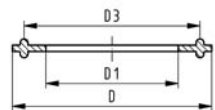

Gasket PTFE

Model:

- Special gasket for Sanitary Adaptors PVDF-PVDF connection

d [mm]	Code	SP	kg	D [mm]	D1 [mm]	D2 [mm]
20	743 400 806	-	0.010	50.5	16.9	43.5
25	743 400 807	-	0.010	20.1	50.5	43.5
32	743 400 808	-	0.010	25.8	50.5	43.5
40	743 400 809	-	0.015	33.6	64.0	56.5
50	743 400 810	-	0.015	42.5	64.0	56.5
63	743 400 811	-	0.017	55.4	77.5	70.5

PF 2 65 456

Flange Adaptors, Flanges and Gaskets

35 79 88

Flange Adaptors PN16; jointing face serrated, PVDF-HP **K**

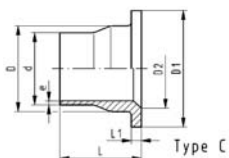
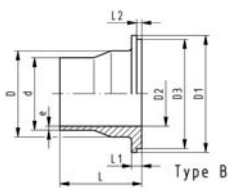
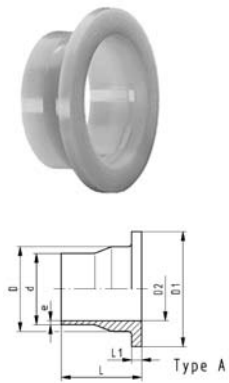

PF 2 37 249

d [mm]	DN [mm]	PN	Code	kg	D [mm]	D1 [mm]	D2 [mm]	D3 [mm]	e [mm]	L [mm]	L1 [mm]	L2 [mm]	Type
20	15	16	735 798 831	0.029	26	45	15		1.9	54	6		A
25	20	16	735 798 832	0.044	32	58	20	54	1.9	56	7	4	B
32	25	16	735 798 833	0.066	40	68	26	63	2.4	58	7	4	B
40	32	16	735 798 834	0.093	49	78	34	73	2.4	68	8	4	B
50	40	16	735 798 835	0.129	60	88	42	82	3.0	69	8	4	B
63	50	16	735 798 836	0.187	75	102	56		3.0	72	9		A
75	65	16	735 798 837	0.298	89	122	66		3.6	80	10		A
90	80	16	735 798 838	0.377	105	138	78	133	4.3	81	12	4	B
110	100	16	735 798 839	0.630	125	158	100		5.3	81	13		C
140	125	16	735 798 841	0.847	155	188	127		6.7	90	16		C
160	150	16	735 798 842	1.200	175	212	151		7.7	93	17		C
200	200	16	735 798 844	1.900	232	268	203		9.6	102	22		C
225	200	16	735 798 845	2.000	235	268	203		10.8	102	22		C

35 79 88

Flange Adaptors PN16, ANSI, jointing face serrated, PVDF-HP **K**

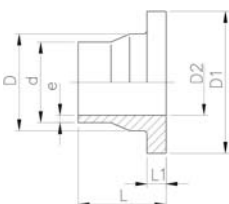

PF 2 37 249

Model:

- Other dimensions identical with metric version

d [mm]	PN	Code	kg	D [mm]	D1 [mm]	D2 [mm]	e [mm]	L [mm]	L1 [mm]
25	16	735 798 882	0.043	32	54	20	1.9	56	7
32	16	735 798 883	0.063	40	63	26	2.4	58	7
40	16	735 798 884	0.089	49	73	34	2.4	68	8

35 79 88 / 35 79 85 Flange Adaptors PN10; jointing face serrated, PVDF-HP **K**

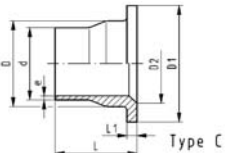
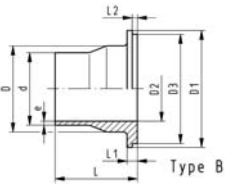
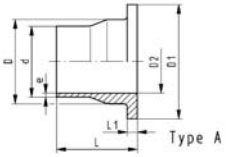

PF 2 37 249

d [mm]	DN [mm]	PN	Code	kg	D [mm]	D1 [mm]	D2 [mm]	D3 [mm]	e [mm]	L [mm]	L1 [mm]	L2 [mm]	Type
90	80	10	735 798 888	0.350	105	138	78	133	2.8	81	12	4	B
110	100	10	735 798 889	0.450	125	158	100		3.4	81	13		A
125	100	10	735 798 590	0.480	132	158	114		3.9	82	14		A
140	125	10	735 798 891	0.710	155	188	127		4.3	90	16		A
160	150	10	735 798 892	1.000	175	212	151		4.9	93	17		C
200	200	10	735 798 894	1.700	232	268	203		6.2	102	22		C
225	200	10	735 798 895	1.600	235	268	203		6.9	102	22		A
250	250	10	735 798 596	2.673	285	320	250		7.7	120	22		C
280	250	10	735 798 597	2.777	291	320	250		8.6	120	22		A
315	300	10	735 798 598	3.436	335	370	306		9.7	120	22		C

27 70 04
27 70 05

Backing Flanges, PP-V for Butt Fusion Systems metric

G

Model:

- Modern full-plastic flange PP-GF (30 % glass-fibre reinforced)
- With V-groove which applies force evenly on collar
- With integrated bolt retainers as an assembly aid
- Connecting dimension: ISO 7005 PN 10, EN 1092 PN 10, DIN 2501 PN 10, BS 4504 PN 10

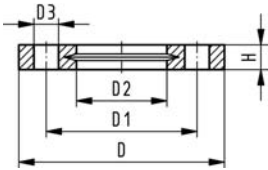
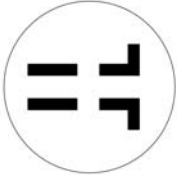

¹⁾ Suitable for socket- and butt fusion systems (no pictograph on flange)

d [mm]	Inch	DN [mm]	PN	Code	SP	kg	D [mm]	D1 [mm]	D2 [mm]	D3 [mm]	H [mm]	AL	SC
20		15	16	727 700 406	-	0.080	95	65	28	14	16	4	M12
25		20	16	727 700 407	-	0.100	105	75	34	14	17	4	M12
32		25	16	727 700 408	-	0.140	115	85	42	14	18	4	M12
40		32	16	727 700 409	-	0.220	140	100	51	18	20	4	M16
50		40	16	727 700 410	-	0.210	150	110	62	18	22	4	M16
63		50	16	727 700 411	-	0.380	165	125	78	18	24	4	M16
75		65	16	727 700 412	-	0.480	185	145	92	18	26	4	M16
90		80	16	727 700 513	-	0.520	200	160	108	18	27	8	M16
110		100	16	727 700 514	-	0.680	220	180	128	18	28	8	M16
125		100	16	727 700 515	-	0.760	220	180	135	18	28	8	M16
140		125	16	727 700 516	-	0.800	250	210	158	18	30	8	M16
160	6	150	16	727 700 517	-	1.200	285	241	178	22	32	8	M20
180		150	16	727 700 518	-	1.200	285	240	188	22	32	8	M20
200	8	200	16	727 700 519	-	1.400	340	295	235	22	34	8	M20
225	9	200	16	727 700 520	-	1.400	340	295	238	22	34	8	M20
250		250	16	727 700 521	-	1.700	395	350	288	22	38	12	M20
280		250	16	727 700 522	-	1.700	395	350	294	22	38	12	M20
315		300	16	727 700 523	-	2.400	445	400	338	22	42	12	M20

PF 2 34 238

27 70 02
27 70 03

Backing Flanges, PP/Steel for Butt Fusion Systems metric

G

Model:

- Material: PP (30 % glass-fibre reinforced) with steel ring
- Connecting dimensions: ISO 7005 / EN 1092 / DIN 2501 PN10 / BS4504

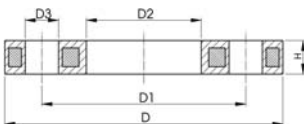
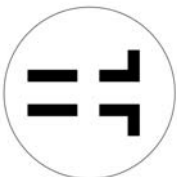

d [mm]	DN [mm]	PN	Code	D [mm]	D1 [mm]	D2 [mm]	D3 [mm]	H [mm]	AL	SC
20	15	16	727 700 206	95	65	28	14	12	4	M12
25	20	16	727 700 207	105	75	34	14	12	4	M12
32	25	16	727 700 208	115	85	42	14	16	4	M12
40	32	16	727 700 209	140	100	51	18	16	4	M16
50	40	16	727 700 210	150	110	62	18	18	4	M16
63	50	16	727 700 211	165	125	78	18	18	4	M16
75	65	16	727 700 212	185	145	92	18	18	4	M16
90	80	16	727 700 313	200	160	108	18	20	8	M16
110	100	16	727 700 314	220	180	128	18	20	8	M16
125	100	16	727 700 315	220	180	135	18	20	8	M16
140	125	16	727 700 316	250	210	158	18	24	8	M16
160	150	16	727 700 317	285	240	178	22	24	8	M20
180	150	16	727 700 318	285	240	188	22	24	8	M20
200	200	16	727 700 319	340	295	235	22	27	8	M20
225	200	16	727 700 320	340	295	238	22	27	8	M20
250	250	16	727 700 321	395	350	288	22	30	12	M20
280	250	16	727 700 322	395	350	294	22	30	12	M20
315	300	16	727 700 323	445	400	338	22	34	12	M20

PF 2 34 238

27 70 14
27 70 15

Backing Flanges, PP-V for Butt Fusion Systems Inch/ANSI

G

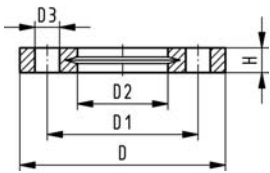
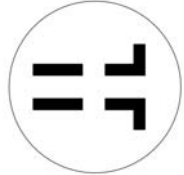

PF 2 34 238

Model:

- Modern full-plastic flange PP-GF (30 % glass-fibre reinforced)
- With V-groove which applies force evenly on collar
- With integrated bolt-fixing as an assembly aid
- Connection dimensions according to ANSI B 16.5, ASTM D 4024; bolt circle class 150

1) Suitable for socket- and butt fusion systems (no pictograph on flange)

Inch	DN [mm]	PN	Code	kg	D [mm]	D1 [mm]	D2 [mm]	D3 [mm]	H [mm]	AL	SC
1/2	15	16	727 701 406	0.080	95	60	28	16	16	4	M12
3/4	20	16	727 701 407	0.100	105	70	34	16	17	4	M12
1	25	16	727 701 408	0.140	115	79	42	16	18	4	M12
1 1/4	32	16	727 701 409	0.220	140	89	51	16	20	4	M16
1 1/2	40	16	727 701 410	0.210	150	98	62	16	22	4	M16
2	50	16	727 701 411	0.380	165	121	78	19	24	4	M16
2 1/2	65	16	727 701 412	0.480	185	140	92	19	26	4	M16
3	80	16	727 701 513	0.520	200	152	108	19	27	4	M16
4	100	16	727 701 514	0.680	229	190	128	19	28	8	M16
6	150	16	727 700 517	1.200	285	241	178	22	32	8	M20
8	200	16	727 700 519	1.400	340	295	235	22	34	8	M20
9	200	16	727 700 520	1.400	340	295	238	22	34	8	M20
10	250	16	727 701 521	1.800	406	362	288	26	38	12	M20
10	250	16	727 701 522	1.700	406	362	294	26	38	12	M20
12	300	16	727 701 523	2.400	483	432	338	26	42	12	M20

27 70 12

Backing Flanges, PP/Steel for Butt Fusion Systems Inch/ANSI

G

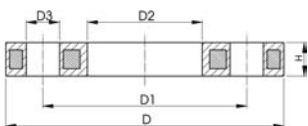
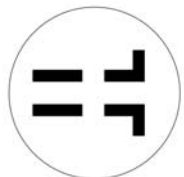

PF 2 34 238

Model:

- For butt fusion systems
- Material: PP (30 % glass-fibre reinforced) with steel ring
- Bolt circle diameter and bolt holes: ANSI B16.5

Inch	DN [mm]	d [mm]	PN	Code	SP	kg	D [mm]	D1 [mm]	D2 [mm]	D3 [mm]	H [mm]	AL
1/2	15	20	16	727 701 206	-	0.210	95	60	28	16	12	4
3/4	20	25	16	727 701 207	-	0.250	105	70	34	16	12	4
1	25	32	16	727 701 208	-	0.420	115	79	42	16	16	4
1 1/4	32	40	16	727 701 209	-	0.670	140	89	51	16	16	4
1 1/2	40	50	16	727 701 210	-	0.860	150	98	62	16	18	4
2	50	63	16	727 701 211	-	0.930	165	121	78	19	18	4
2 1/2	65	75	16	727 701 212	-	1.340	185	140	92	19	18	4
3	80	90	16	727 701 313			200	152	108	19	20	4
4	100	110	16	727 701 314			229	190	128	19	20	8
6	150	160	16	727 701 317			285	241	178	22	24	8
(8)	200	200	16	727 701 319			340	298	235	22	27	8
8	200	225	16	727 701 320			340	298	238	22	27	8

SYGEF® Plus

Backing Flange PVDF/Steel for Butt Fusion Systems metric

Model:

- Material: PVDF (blue) coated steel
- Bolt circle diameter and bolt holes: ANSI B16.5 #150

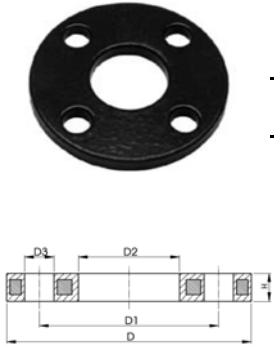

d	DN	Inch	Code	PN	KG	D (mm)	D1 (mm)	D2 (mm)	D3 (mm)	H (mm)	AL
20	15	¾	155 701 806	16	0.23	89	60	28	16	7	4
25	20	¾	155 701 807	16	0.34	98	70	34	16	7	4
32	25	1	155 701 808	16	0.34	108	79	42	16	7	4
40	32	1¼	155 701 809	16	0.51	117	89	51	16	8	4
50	40	1½	155 701 810	16	0.60	127	98	62	16	8	4
63	50	2	155 701 811	16	0.97	152	121	78	19	10	4
75	65	2½	155 701 812	16	1.34	178	140	92	19	10	4
90	80	3	155 701 813	16	1.45	190	152	110	19	10	4
110	100	4	155 701 814	16	2.07	229	190	133	19	10	8
160	150	6	155 701 917	16	3.34	279	241	179	22	13	8
200	200	8	155 701 919	16	5.96	343	298	236	22	16	8
225	200	8/9	155 701 920	16	5.75	343	298	239	22	16	8
250	225	10	155 701 921	10	7.62	406	362	288	22	22	12
315	300	12	155 701 923	10	18.18	483	432	338	25	25	12

SYGEF Plus Gasket

Model:

- TFM (tetrafluoroethylene) coated EPDM
- Self-centering design
- Multiple use gasket
- Specially cleaned & double-bagged
- Compatible with ANSI, ISO/DIN & JIS Flange Adaptors
- Must be used with Steel Backing Flange (not for use with PP-V Flange)

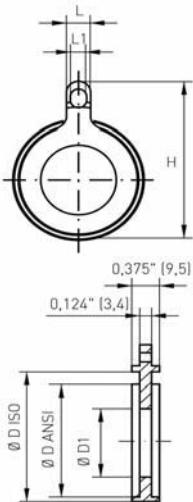

d	DN	Inch	Code	H	D ISO (mm)	D ANSI (inch)	L (mm)	L1 (mm)	D1 (mm)	Torque (Nm)
25	20	¾	731 400 753	76	58	2.13	20	13	23	9
32	25	1	731 400 755	91	68	2.48	25	16	30	10
40	32	1¼	731 400 757	101	78	2.87	25	16	38	20
50	40	1½	731 400 759	110	88	3.23	25	16	46	25
63	50	2	731 400 760	128	102	4.02	25	16	59	30
75	65	2½	731 400 761	148	122	4.80	25	16	67	35
90	80	3	731 400 763	161	138	5.24	25	16	80	40
110	100	4	731 400 764	189	158	6.22	25	16	98	45
140	125	5	731 400 666	219	188	7.40	30	20	129	50
160	150	6	731 400 667	244	212	8.35	30	20	148	60
200	200	8	731 400 669	300	268	10.55	30	20	185	75
225	200	8/9	731 400 670	300	268	10.55	30	20	209	75
250	225	10	731 400 671	369	320	12.60	35	22	250	80

Diaphragm valves

SYGEF® PLUS Diaphragm valve type 314 With butt fusion spigots

J

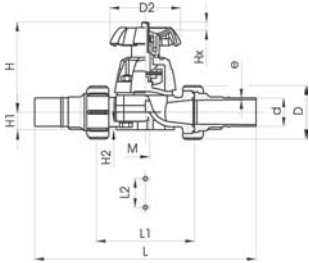

Model:

- Diaphragm PTFE with EPDM backing diaphragm (FDA compliant)
- For easy installation and removal
- Short overall length
- Welding dimension: PN16

Option:

- Handwheel with built-in locking mechanism (standard version is nonlockable)

d [mm]	DN [mm]	PN	kv-value ($\Delta p=1$ bar) [l/min]	PTFE/EPDM Code	kg
20	15	10	72	175 314 362	0.500
25	20	10	137	175 314 363	0.725
32	25	10	207	175 314 364	1.000
40	32	10	354	175 314 365	1.600
50	40	10	517	175 314 366	2.092
63	50	10	713	175 314 367	3.619

d [mm]	D [mm]	D2 [mm]	e [mm]	H [mm]	H1 [mm]	H2 [mm]	L [mm]	L1 [mm]	L2 [mm]	M
20	45	80	1.9	90	14	12	225	90	25	M6
25	55	80	1.9	101	18	12	242	108	25	M6
32	62	94	2.4	117	22	12	254	116	25	M6
40	75	117	2.4	127	26	15	308	134	45	M8
50	84	117	3.0	139	32	15	330	154	45	M8
63	101	152	3.0	172	39	15	373	184	45	M8

PF 2 65 435

SYGEF® PLUS Diaphragm valve type 314 HTR With butt fusion spigots

J

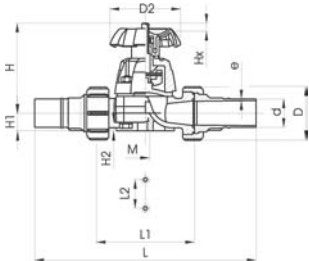

Model:

- High Temperature Resistent (HTR)
- With additional sealing element FPM white (FDA compliant)
- Diaphragm PTFE with EPDM backing diaphragm (FDA compliant)
- For easy installation and removal
- Short overall length
- Welding dimension: PN16
- Red handwheel

d [mm]	DN [mm]	PN	kv-value ($\Delta p=1$ bar) [l/min]	PTFE/EPDM FPM SEALING ELEMENT Code	kg
20	15	10	72	175 314 662	0.500
25	20	10	137	175 314 663	0.725
32	25	10	207	175 314 664	1.000
40	32	10	354	175 314 665	1.600
50	40	10	517	175 314 666	2.092
63	50	10	713	175 314 667	3.619

d [mm]	D [mm]	D2 [mm]	e [mm]	H [mm]	H1 [mm]	H2 [mm]	L [mm]	L1 [mm]	L2 [mm]	M
20	45	80	1.9	90	14	12	225	90	25	M6
25	55	80	1.9	101	18	12	242	108	25	M6
32	62	94	2.4	117	22	12	254	116	25	M6
40	75	117	2.4	127	26	15	308	134	45	M8
50	84	117	3.0	139	32	15	330	154	45	M8
63	101	152	3.0	172	39	15	373	184	45	M8

PF 2 65 435



SYGEF® PLUS Diaphragm valve type 315 With butt fusion ends metric

J

Model:

- Diaphragm PTFE with EPDM backing diaphragm (FDA compliant)
- Welding dimension: PN16

Option:

- Handwheel with built-in locking mechanism (standard version is nonlockable)

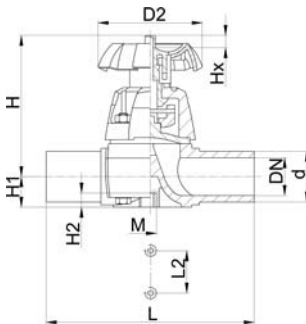

PF 2 37 206

d [mm]	DN [mm]	PN	kv-value ($\Delta p=1$ bar) [l/min]	PTFE with EPDM supp. diaphragm Code	kg	D2 [mm]	H [mm]	H1 [mm]	H2 [mm]	L [mm]	L2 [mm]	M
20	15	10	72	175 315 562	0.360	80	90	14	12	124	25	M6
25	20	10	137	175 315 563	0.560	80	102	18	12	144	25	M6
32	25	10	207	175 315 564	0.804	94	119	21	12	154	25	M6
40	32	10	354	175 315 565	1.025	117	126	26	15	174	45	M8
50	40	10	517	175 315 566	1.480	117	139	33	15	194	45	M8
63	50	10	713	175 315 567	2.581	152	172	39	15	224	45	M8
75	65	10	992	175 315 368	4.343	152	210	46	15	214	70	M8



SYGEF® PLUS Diaphragm valve type 315 HTR With butt fusion ends metric

J

Model:

- High Temperature Resistant (HTR)
- Diaphragm PTFE with EPDM backing diaphragm (FDA compliant)
- With additional sealing element FPM white (FDA compliant)
- Welding dimension: PN16
- Further versions: with backing diaphragm FPM on request
- Red handwheel

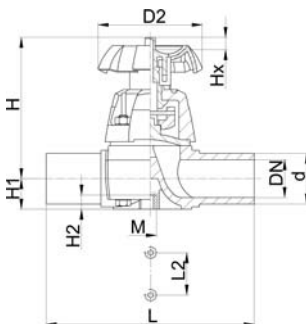

PF 2 37 206

d [mm]	DN [mm]	PN	kv-value ($\Delta p=1$ bar) [l/min]	PTFE/EPDM FPM SEALING ELEMENT Code	kg	D2 [mm]	H [mm]	H1 [mm]	H2 [mm]	L [mm]	L2 [mm]	M
20	15	10	72	175 315 602	0.360	80	90	14	12	124	25	M6
25	20	10	137	175 315 603	0.560	80	102	18	12	144	25	M6
32	25	10	207	175 315 604	0.804	94	119	21	12	154	25	M6
40	32	10	354	175 315 605	1.025	117	126	26	15	174	45	M8
50	40	10	517	175 315 606	1.480	117	139	33	15	194	45	M8
63	50	10	713	175 315 607	2.581	152	172	39	15	224	45	M8



SYGEF® PLUS

Diaphragm valve type 317

Flanged connection metric

J

Model:

- DN 15-65 with backing flange
- DN 80-150 with fixed flange
- Overall length according to EN 558-1
- Diaphragm PTFE with EPDM backing diaphragm (FDA compliant)

Option:

- Handwheel with built-in locking mechanism (standard version is nonlockable)

* DN80 and DN150 fixed flanges metric and Inch ANSI B16.5

d [mm]	DN [mm]	Inch	PN	kv-value ($\Delta p=1$ bar) [l/min]	PTFE/EPDM Code	kg
20	15	1/2	10	72	175 317 447	0.580
25	20	3/4	10	137	175 317 448	0.858
32	25	1	10	207	175 317 449	1.205
40	32	1 1/4	10	354	175 317 450	2.270
50	40	1 1/2	10	517	175 317 451	2.260
63	50	2	10	713	175 317 452	3.700
75	65	2 1/2	10	992	175 317 453	5.700
*90	80	3	10	1700	175 317 054	10.700
110	100	4	10	2700	175 317 055	14.890
*160	150	6	7	6033	175 317 057	31.000

d [mm]	D [mm]	D1 [mm]	D2 [mm]	D3 [mm]	H [mm]	H1 [mm]	H2 [mm]	L [mm]	L1 [mm]	L2 [mm]	L3 [mm]	M	AL
20	95	65	80	14	90	14	12	130		25		M6	4
25	105	75	80	14	102	18	12	150		25		M6	4
32	115	85	94	14	119	21	12	160		25		M6	4
40	140	100	117	18	126	26	15	180		45		M8	4
50	150	110	117	18	139	33	15	200		45		M8	4
63	165	125	152	18	172	39	15	230		45		M8	4
75	185	145	152	18	201	46	15	290		70		M8	4
*90	200	152	270	18	265	57	23	310	35	120		M12	8
110	225	180	270	18	302	68	23	350	35	120		M12	8
*160	285	240	400	22	437	108	23	480	26	100	200	M12	8

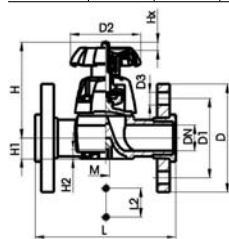

DN 15-65

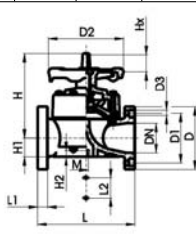

DN 80-100

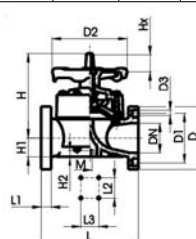

DN 150

PF 2 37 206



SYGEF® PLUS

Diaphragm valve type 317

Flanged version ANSI

J

Model:

- DN 15-65 with backing flange
- DN 80-150 with fixed flange
- Overall length according to EN 558-1
- Diaphragm PTFE with EPDM backing diaphragm (FDA compliant)

Option:

- Handwheel with built-in locking mechanism (standard version is nonlockable)

* DN80 and DN150 fixed flanges metric and Inch ANSI B16.5

d [mm]	DN [mm]	Inch	PN	kv-value ($\Delta p=1$ bar) [l/min]	PTFE with EPDM supp. Diaphragm Code	kg
20	15	½	10	72	175 317 562	0.760
25	20	¾	10	137	175 317 563	1.210
32	25	1	10	207	175 317 564	1.620
40	32	1 ¼	10	354	175 317 565	2.270
50	40	1 ½	10	517	175 317 566	2.810
63	50	2	10	713	175 317 567	4.230
75	65	2 ½	10	992	175 317 568	5.700
*90	80	3	10	1700	175 317 054	10.700
110	100	4	10	2700	175 317 355	14.950

d [mm]	D [mm]	D1 [mm]	D2 [mm]	D3 [mm]	H [mm]	H1 [mm]	H2 [mm]	L [mm]	L1 [mm]	L2 [mm]	M	AL
20	95	61	80	14	90	14	12	130		25	M6	4
25	105	70	80	14	93	18	12	150		25	M6	4
32	115	80	94	14	119	21	12	160		25	M6	4
40	140	89	117	18	126	26	15	180		45	M8	4
50	150	99	117	18	139	33	15	200		45	M8	4
63	165	121	152	18	172	39	15	230		45	M8	4
75	185	140	152	18	201	46	15	290		70	M8	4
*90	200	152	270	18	265	57	23	310	35	120	M12	8
110	225	191	270	18	302	68	23	350	35	120	M12	8

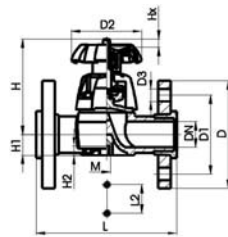

DN 15-65

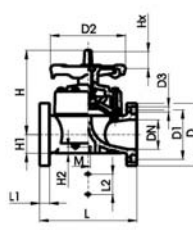

DN 80-100

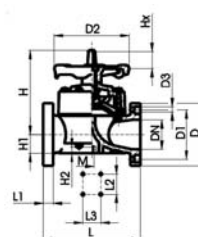

DN 150

PF 2 37 206



SYGEF® PLUS

Diaphragm valve type 319

With butt fusion spigots

J

Model:

- Diaphragm PTFE with EPDM backing diaphragm (FDA compliant)
- Welding dimension: PN16

Option:

- Handwheel with built-in locking mechanism (standard version is nonlockable)

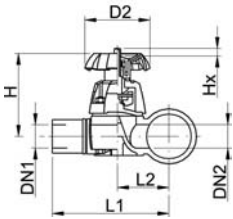
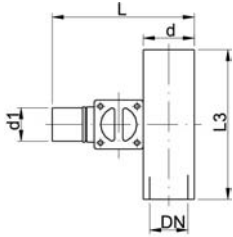

d [mm]	d1 [mm]	DN [mm]	DN1 [mm]	DN2 [mm]	PN	kv-value ($\Delta p=1$ bar) [l/min]	PTFE/EPDM Code	kg
20	20	15	15	15	10	47	175 319 301	0.366
25	20	20	15	20	10	69	175 319 303	0.548
25	25	20	20	20	10	91	175 319 304	0.548
32	20	25	15	25	10	86	175 319 307	0.759
32	25	25	20	25	10	126	175 319 308	0.756
32	32	25	25	25	10	156	175 319 309	0.754
40	20	32	15	25	10	84	175 319 312	0.449
40	25	32	20	25	10	124	175 319 313	0.810
40	32	32	25	25	10	161	175 319 314	0.810
40	40	32	32	32	10	250	175 319 315	1.210
50	20	40	15	25	10	82	175 319 318	0.873
50	25	40	20	25	10	124	175 319 319	0.934
50	32	40	25	25	10	159	175 319 320	0.868
50	40	40	32	40	10	312	175 319 321	1.685
50	50	40	40	40	10	356	175 319 322	1.680
63	20	50	15	25	10	81	175 319 325	0.937
63	25	50	20	25	10	115	175 319 326	0.934
63	32	50	25	25	10	156	175 319 327	0.932
63	40	50	32	50	10	383	175 319 328	2.635
63	50	50	40	50	10	487	175 319 329	2.610
63	63	50	50	50	10	544	175 319 330	2.615
75	40	65	32	32	10	256	175 319 336	1.320
75	50	65	40	50	10	497	175 319 337	2.710
75	63	65	50	50	10	546	175 319 338	2.710
90	20	80	15	25	10	88	175 319 341	1.178
90	25	80	20	25	10	133	175 319 342	1.176
90	32	80	25	25	10	162	175 319 343	1.172
90	50	80	40	50	10	504	175 319 345	2.968
90	63	80	50	50	10	530	175 319 346	2.968
110	20	100	15	25	10	89	175 319 351	1.288
110	25	100	20	25	10	123	175 319 352	1.286
110	32	100	25	25	10	159	175 319 353	1.283
110	50	100	50	50	10	503	175 319 355	3.258
110	63	100	50	50	10	543	175 319 356	3.250

d [mm]	Lift = Hx [mm]	D2 [mm]	H [mm]	L [mm]	L1 [mm]	L2 [mm]	L3 [mm]
20	8	80	87	106	96	30	140
25	11	80	101	121	108	36	150
25	11	80	101	121	108	36	150
32	13	94	119	137	120	43	160
32	13	94	119	137	120	43	160
32	13	94	119	137	120	43	160
40	12	94	116	149	128	51	180
40	12	94	116	149	128	51	180
40	12	94	116	149	128	51	180
40	16	117	127	174	153	56	190
50	8	94	116	159	134	57	180
50	13	94	119	159	134	57	180
50	13	94	119	159	134	57	180
50	19	117	139	195	169	66	200

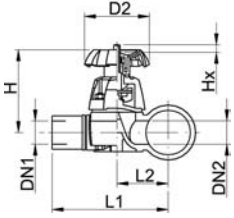
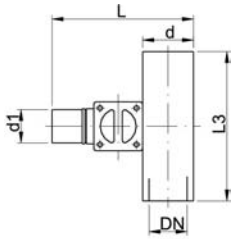

d [mm]	Lift = Hx [mm]	D2 [mm]	H [mm]	L [mm]	L1 [mm]	L2 [mm]	L3 [mm]	
50	19	117	139	195	169	66	200	
63	13	94	116	175	144	67	180	
63	13	94	116	175	144	67	180	
63	13	94	119	175	144	67	180	
63	27	152	172	223	192	80	220	
63	28	152	172	225	192	80	220	
63	27	152	172	223	192	80	220	
75	16	117	126	203	166	78	190	
75	27	152	172	236	198	86	220	
75	27	152	172	236	198	86	220	
90	13	94	119	204	159	82	160	
90	13	94	119	204	159	82	160	
90	13	94	119	204	159	82	160	
90	28	152	172	252	207	95	220	
90	28	152	172	252	207	95	220	
110	13	94	116	226	171	94	160	
110	13	94	116	226	171	94	160	
110	13	94	116	226	171	94	160	
110	28	152	172	274	219	107	220	
110	28	152	172	274	219	107	220	

PF 2 65 435



SYGEF® Plus Diaphragm valve type 319 HTR

With butt fusion spigots

J

Model:

- High Temperature Resistant (HTR)
- Diaphragm PTFE with EPDM backing diaphragm (FDA compliant)
- Suitable for butt and BCF® fusion
- Welding dimension: PN16
- With additional sealing element FPM white (FDA compliant)
- Red handwheel

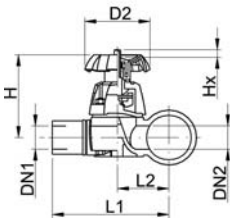
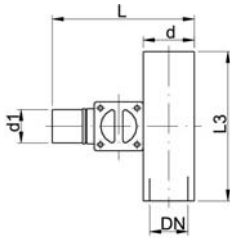

d [mm]	d1 [mm]	DN [mm]	DN1 [mm]	DN2 [mm]	PN	kv-value ($\Delta p=1$ bar) [l/min]	WITH PTFE/EPDM FPM SEALING ELEMENT Code	kg
20	20	15	15	15	10	47	175 319 601	0.366
25	20	20	15	20	10	69	175 319 603	0.546
25	25	20	20	20	10	91	175 319 604	0.548
32	20	25	15	25	10	86	175 319 607	0.759
32	25	25	20	25	10	126	175 319 608	0.756
32	32	25	25	25	10	156	175 319 609	0.754
40	20	32	15	25	10	84	175 319 612	0.449
40	25	32	20	25	10	124	175 319 613	0.810
40	32	32	25	25	10	161	175 319 614	0.810
40	40	32	32	32	10	250	175 319 615	1.210
50	20	40	15	25	10	82	175 319 618	0.873
50	25	40	20	25	10	124	175 319 619	0.872
50	32	40	25	25	10	159	175 319 620	0.868
50	40	40	32	40	10	312	175 319 621	1.685
50	50	40	40	40	10	356	175 319 622	1.680
63	20	50	15	25	10	81	175 319 625	0.937
63	25	50	20	25	10	115	175 319 626	0.934
63	32	50	25	25	10	156	175 319 627	0.932
63	40	50	32	50	10	383	175 319 628	2.635
63	50	50	40	50	10	487	175 319 629	2.610
63	63	50	50	50	10	544	175 319 630	2.615
75	40	65	32	32	10	256	175 319 636	1.320
75	50	65	40	50	10	497	175 319 637	2.710
75	63	65	50	50	10	546	175 319 638	2.710
90	20	80	15	25	10	88	175 319 641	1.178
90	25	80	20	25	10	133	175 319 642	1.176
90	32	80	25	25	10	162	175 319 643	1.172
90	50	80	40	50	10	504	175 319 645	2.968
90	63	80	50	50	10	530	175 319 646	2.968
110	20	100	15	25	10	89	175 319 651	1.288
110	25	100	20	25	10	123	175 319 652	1.286
110	32	100	25	25	10	159	175 319 653	1.283
110	50	100	40	50	10	503	175 319 655	3.258
110	63	100	50	50	10	543	175 319 656	3.250

d [mm]	Lift = Hx [mm]	D2 [mm]	H [mm]	L [mm]	L1 [mm]	L2 [mm]	L3 [mm]
20	8	80	87	106	96	30	140
25	11	80	101	121	108	36	150
25	11	80	101	121	108	36	150
32	13	94	119	137	120	43	160
32	13	94	119	137	120	43	160
32	13	94	119	137	120	43	160
40	12	94	116	149	128	51	180
40	12	94	116	149	128	51	180
40	12	94	116	149	128	51	180

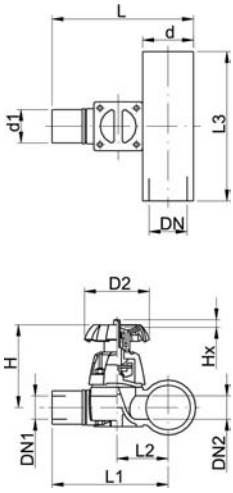

d [mm]	Lift = Hx [mm]	D2 [mm]	H [mm]	L [mm]	L1 [mm]	L2 [mm]	L3 [mm]	
40	16	117	127	174	153	56	190	
50	8	94	116	159	134	57	180	
50	13	94	119	159	134	57	180	
50	13	94	119	159	134	57	180	
50	19	117	139	195	169	66	200	
50	19	117	139	195	169	66	200	
63	13	94	116	175	144	67	180	
63	13	94	116	175	144	67	180	
63	13	94	119	175	144	67	180	
63	27	152	172	223	192	80	220	
63	28	152	172	225	192	80	220	
63	27	152	172	223	192	80	220	
75	16	117	126	203	166	78	190	
75	27	152	172	236	198	86	220	
75	27	152	172	236	198	86	220	
90	13	94	119	204	159	82	160	
90	13	94	119	204	159	82	160	
90	13	94	119	204	159	82	160	
90	28	152	172	252	207	95	220	
90	28	152	172	252	207	95	220	
110	13	94	116	226	171	94	160	
110	13	94	116	226	171	94	160	
110	13	94	116	226	171	94	160	
110	28	152	172	274	219	107	220	
110	28	152	172	274	219	107	220	

PF 2 65 435

Type 522 Sample Valves

B



PF 2 35 440

Inch	PN	Description	Code	kg	
1/4	16	1/4 NPT Port- Globe Body	155 522 554	0.140	
3/8	16	1/4 NPT Port- Globe Body	155 522 555	0.140	
1/2	16	1/4 NPT Port- Globe Body	155 522 556	0.140	
1/4	16	1/4 NPT Port- Angle Body	155 522 579	0.140	
3/8	16	1/4 NPT Port- Angle Body	155 522 580	0.140	
1/2	16	1/4 NPT Port- Angle Body	155 522 581	0.140	

SYGEF® Plus

Butterfly Valve Type 365 Lug-Style - Bareshaft



Model:

- Metal lugged body with epoxy-coating
- PFA coated disc with PTFE liner
- HP produced & double-bagged
- Bareshaft to ISO5211
- Lugged body to ANSI B16.5 #150 or ISO/EN 1092 PN16
- Pneumatic actuated version available, see separate page

d (mm)	DN (mm)	Inch	PN	Kv value L/min (ΔP=1BAR)	Lugged ANSI B16.5 #150 Code	Lugged ISO/EN 1092 Code	KG	Torque Nm	ISO5211 (square shaft)
63	50	2	16	3199	160 365 423	160 365 551	4.7	30	F07/11mm
75	65	2½	16	3199	160 365 424	160 365 552	6	30	F07/11mm
90	80	3	16	6497	160 365 425	160 365 553	6.5	40	F07/11mm
110	100	4	16	9696	160 365 426	160 365 554	8.5	50	F07/14mm
140	125	5	16	16808	160 365 427	160 365 555	10.6	60	F07/14mm
160	150	6	16	24762	160 365 428	160 365 556	13.9	110	F07/17mm
225	200	8	10	50523	160 365 429	160 365 557	17.9	180	F10/17mm
280	250	10	10	74713	160 365 430	160 365 558	27.2	250	F10/22mm
315	300	12	10	119438	160 365 431	160 365 559	35.9	350	F10/22mm

Handlever for Butterfly Valve Type 365



d	DN	Inch	Code
63-90	50-80	2-3	161 486 065
110-140	100-125	4-5	161 486 066
160	150	6	161 486 067

Gearbox for Butterfly Valve Type 365



d	DN	Inch	Code
63-90	50-80	2-3	198 806 690
110-140	100-125	4-5	198 806 691
160-225	150-200	6-8	198 806 692
280-315	250-300	10-12	198 806 693

- Order bareshaft valve and handlever/gearbox as separate items

Diaphragm valves pneumatic

SYGEF® PLUS

Diaphragm valve type DIASTAR 028

Function FC (Fail safe to close)

With butt fusion spigots IR metric

E



- With position indicator / Working pressure: **one side**

d [mm]	DN [mm]	PN	kv-value ($\Delta p=1$ bar) [l/min]	PTFE/EPDM Code	kg
20	15	5	72	199 028 971	0.520
25	20	7	120	199 028 972	0.950
32	25	7	238	199 028 973	1.370
40	32	7	341	199 028 974	1.810
50	40	7	460	199 028 975	3.350
63	50	7	685	199 028 976	6.270

d [mm]	D [mm]	D1_G [inch]	D3[M] [mm]	L [mm]	L1 [mm]	L2 [mm]	H [mm]	H1 [mm]	H2 [mm]	H3 [mm]	H4 [mm]	H5 [mm]	H6 [mm]	H7 [mm]	H8 [mm]
20	68	1/8	6	124	60	25	98	59	24	23	44	100	155	44	76
25	96	1/8	6	144	60	25	127	71	25	23	44	100	155	56	88
32	96	1/8	6	154	60	25	141	85	25	23	44	100	155	56	88
40	120	1/8	8	174	60	45	167	97	26	36	64	100	160	68	100
50	150	1/4	8	194	60	45	198	108	36	36	64	100	170	85	117
63	150	1/4	8	224	60	45	216	126	36	36	64	100	170	85	117

d [mm]	H9 [mm]	H10 [mm]	Lift = Hx [mm]
20	14	12	8
25	18	12	10
32	21	12	12
40	26	15	14
50	33	15	18
63	39	15	22

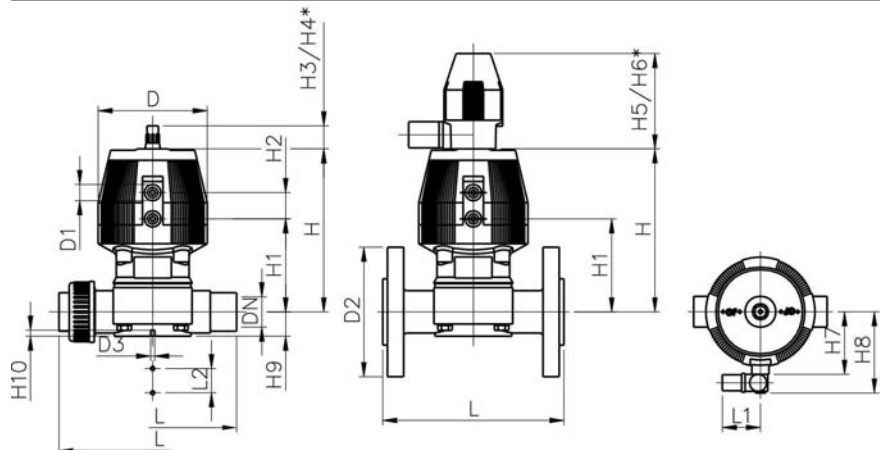

PF 3 39 212



SYGEF® PLUS

Diaphragm valve type DIASTAR 028

Function FC (Fail safe to close)

Unions with fusion spigots metric

E

- With position indicator / Working pressure: **one side**

d [mm]	DN [mm]	PN	kv-value ($\Delta p=1$ bar) [l/min]	PTFE/EPDM Code	kg
20	15	5	72	199 028 401	0.839
25	20	7	120	199 028 402	0.950
32	25	7	238	199 028 403	1.370
40	32	7	341	199 028 404	2.370
50	40	7	460	199 028 405	3.850
63	50	7	685	199 028 406	6.270

d [mm]	D [mm]	D1_G [inch]	D3[M] [mm]	L [mm]	L1 [mm]	L2 [mm]	H [mm]	H1 [mm]	H2 [mm]	H3 [mm]	H4 [mm]	H5 [mm]	H6 [mm]	H7 [mm]	H8 [mm]
20	68	1/8	6	225	60	25	98	59	24	23	44	100	155	44	76
25	96	1/8	6	242	60	25	127	71	25	23	44	100	155	56	88
32	96	1/8	6	254	60	25	141	85	25	23	44	100	155	56	88
40	120	1/8	8	308	60	45	167	97	26	36	64	100	160	68	100
50	150	1/4	8	330	60	45	198	108	36	36	64	100	170	85	117
63	150	1/4	8	373	60	45	216	126	36	36	64	100	170	85	117

d [mm]	H9 [mm]	H10 [mm]	Lift = Hx [mm]
20	14	12	8
25	18	12	10
32	21	12	12
40	26	15	14
50	33	15	18
63	39	15	22

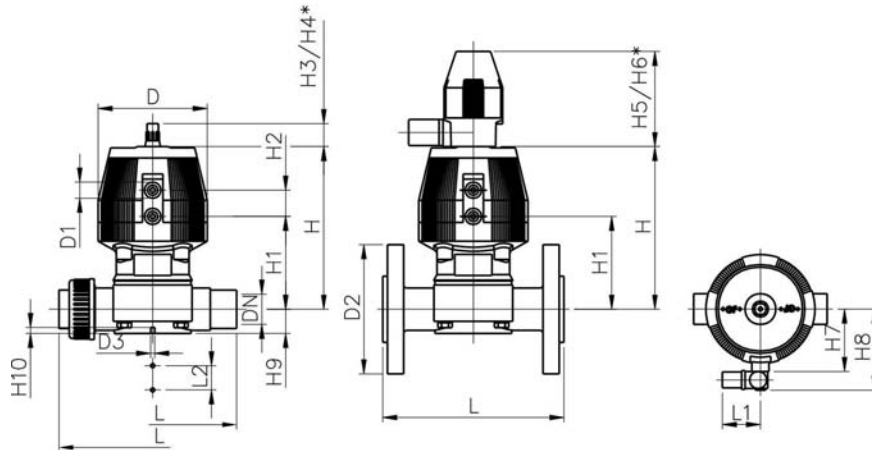

PF 3 39 212



SYGEF® PLUS

Diaphragm valve type DIASTAR 028

Function FC (Fail safe to close)

With backing flanges PP-V metric

E

Model:

- Connecting dimensions: ISO 7005 / EN 1092 / DIN 2501 PN10 / BS4504
- With position indicator / Working pressure: **one side**

d [mm]	DN [mm]	Inch	PN	kv-value ($\Delta p=1$ bar) [l/min]	PTFE/EPDM Code	kg
20	15	½	5	72	199 028 441	0.890
25	20	¾	7	120	199 028 442	1.300
32	25	1	7	238	199 028 443	1.820
40	32	1 ¼	7	341	199 028 444	2.370
50	40	1 ½	7	460	199 028 445	3.850
63	50	2	7	685	199 028 446	6.350

d [mm]	D [mm]	D1_G [inch]	D3[M] [mm]	D2 [mm]	L [mm]	L1 [mm]	L2 [mm]	H [mm]	H1 [mm]	H2 [mm]	H3 [mm]	H4 [mm]	H5 [mm]	H6 [mm]	H7 [mm]
20	68	¾	6	95	130	60	25	98	59	24	23	44	100	155	44
25	96	¾	6	105	150	60	25	127	71	25	23	44	100	155	56
32	96	¾	6	115	160	60	25	141	85	25	23	44	100	155	56
40	120	¾	8	140	180	60	45	167	97	26	36	64	100	160	68
50	150	¾	8	150	200	60	45	198	108	36	36	64	100	170	85
63	150	¾	8	165	230	60	45	216	126	36	36	64	100	170	85

d [mm]	H8 [mm]	H9 [mm]	H10 [mm]	Lift = Hx [mm]
20	76	14	12	8
25	88	18	12	10
32	88	21	12	12
40	100	26	15	14
50	117	33	15	18
63	117	39	15	22

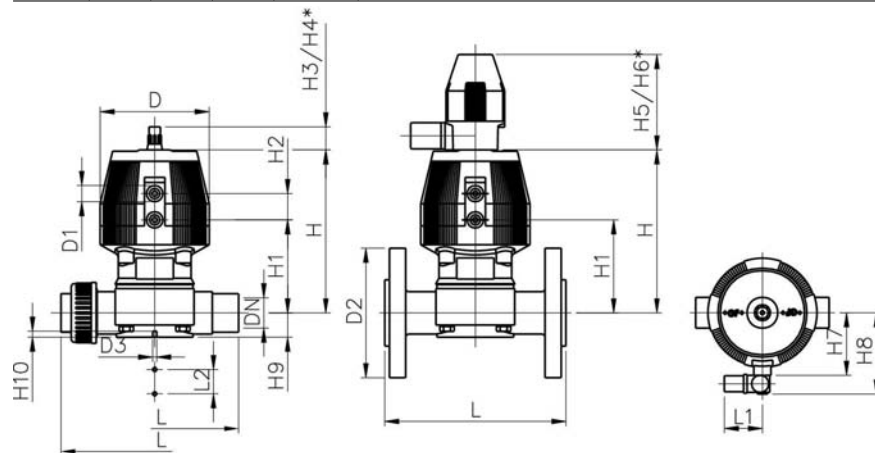

PF 3 39 212



SYGEF® PLUS

Diaphragm valve type DIASTAR 028

Function FC (Fail safe to close)

With backing flanges PP-V ANSI

E

Model:

- Overall length according to EN 558-1
- Connecting dimension: ANSI B 16.5 class 150 (ASTM D 4024), BS EN 1759
- With position indicator / Working pressure: **one side**

Inch	DN [mm]	PN	kv-value ($\Delta p=1$ bar) [l/min]	PTFE/EPDM Code
½	15	5	72	199 028 581
¾	20	7	120	199 028 582
1	25	7	238	199 028 583
1 ¼	32	7	341	199 028 584
1 ½	40	7	460	199 028 585
2	50	7	685	199 028 586

Inch	D [mm]	D1_G [inch]	D3[M] [mm]	D2 [mm]	L [mm]	L1 [mm]	L2 [mm]	H [mm]	H1 [mm]	H2 [mm]	H3 [mm]	H4 [mm]	H5 [mm]	H6 [mm]
½	68	⅝	6	95	130	60	25	98	59	24	23	44	100	155
¾	96	⅝	6	105	150	60	25	127	71	25	23	44	100	155
1	96	⅝	6	115	160	60	25	141	85	25	23	44	100	155
1 ¼	120	⅝	8	140	180	60	45	167	97	26	36	64	100	160
1 ½	150	¼	8	150	200	60	45	198	108	36	36	64	100	170
2	150	¼	8	165	230	60	45	216	126	36	36	64	100	170

Inch	H7 [mm]	H8 [mm]	H9 [mm]	H10 [mm]	Lift = Hx [mm]
½	44	76	14	12	8
¾	56	88	18	12	10
1	56	88	21	12	12
1 ¼	68	100	26	15	14
1 ½	85	117	33	15	18
2	85	117	39	15	22

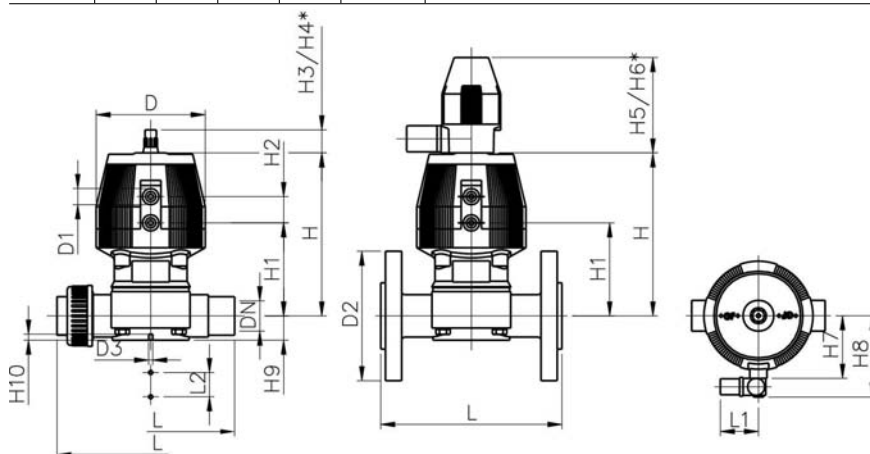

PF 3 39 212



SYGEF® PLUS
Diaphragm valve type DIASTAR 025
Function FC (Fail safe to close)
With butt fusion spigots IR metric

E

- With position indicator / Working pressure: both sides

d [mm]	DN [mm]	PN	kv-value ($\Delta p=1$ bar) [l/min]	PTFE/EPDM Code	kg
20	15	10	72	199 025 971	0.839
25	20	10	120	199 025 972	0.936
32	25	10	238	199 025 973	1.705
40	32	10	341	199 025 974	2.904
50	40	10	460	199 025 975	4.665
63	50	10	685	199 025 976	5.353

d [mm]	D [mm]	D1_G [inch]	D3[M] [mm]	L [mm]	L1 [mm]	L2 [mm]	H [mm]	H1 [mm]	H2 [mm]	H3 [mm]	H4 [mm]	H5 [mm]	H6 [mm]	H7 [mm]	H8 [mm]
20	96	1/8	6	124	60	25	125	69	25	23	44	100	155	56	86
25	96	1/8	6	144	60	25	127	71	25	23	44	100	155	56	88
32	120	1/8	6	154	60	25	163	93	26	36	64	100	155	68	100
40	150	1/4	8	174	60	45	196	106	36	36	64	100	160	85	117
50	180	1/4	8	194	60	45	227	119	37	36	64	100	170	101	133
63	180	1/4	8	224	60	45	241	133	37	36	64	100	170	101	133

d [mm]	H9 [mm]	H10 [mm]	Lift = Hx [mm]
20	14	12	8
25	18	12	10
32	21	12	12
40	26	15	14
50	33	15	18
63	39	15	22

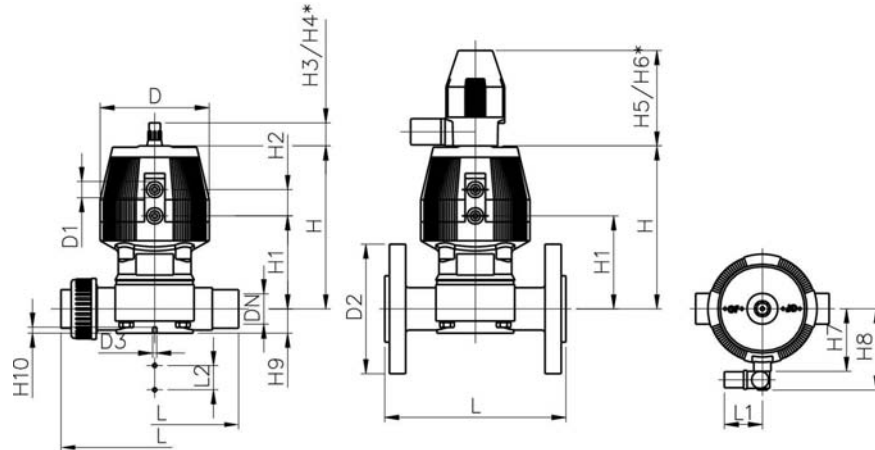

PF 3 39 212



SYGEF® PLUS

Diaphragm valve type DIASTAR 025

Function FC (Fail safe to close)

Unions with fusion spigots metric

E

- With position indicator / Working pressure: both sides

d [mm]	DN [mm]	PN	kv-value ($\Delta p=1$ bar) [l/min]	PTFE/EPDM Code	kg
20	15	10	72	199 027 401	0.839
25	20	10	120	199 027 402	0.936
32	25	10	238	199 027 403	1.705
40	32	10	341	199 027 404	2.370
50	40	10	460	199 027 405	2.510
63	50	10	685	199 027 406	5.353

d [mm]	D [mm]	D1_G [inch]	D3[M] [mm]	L [mm]	L1 [mm]	L2 [mm]	H [mm]	H1 [mm]	H2 [mm]	H3 [mm]	H4 [mm]	H5 [mm]	H6 [mm]	H7 [mm]	H8 [mm]
20	96	1/8	6	196	60	25	125	69	25	23	44	100	155	56	86
25	96	1/8	6	220	60	25	127	71	25	23	44	100	155	56	88
32	120	1/8	6	234	60	25	163	93	26	36	64	100	155	68	100
40	150	1/4	8	258	60	45	196	106	36	36	64	100	160	85	117
50	180	1/4	8	284	60	45	227	119	37	36	64	100	170	101	133
63	180	1/4	8	320	60	45	241	133	37	36	64	100	170	101	133

d [mm]	H9 [mm]	H10 [mm]	Lift = Hx [mm]
20	14	12	8
25	18	12	10
32	21	12	12
40	26	15	14
50	33	15	18
63	39	15	22

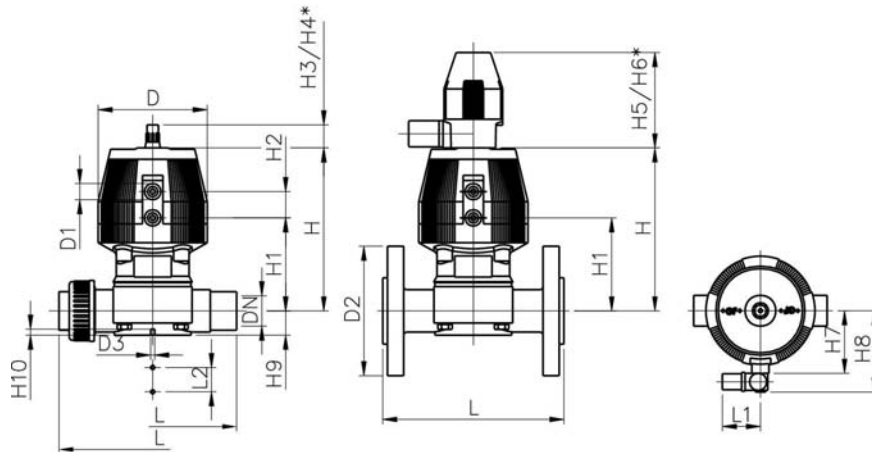

PF 3 39 212



SYGEF® PLUS
Diaphragm valve type DIASTAR 025
Function FC (Fail safe to close)
With backing flanges PP-V metric

E

Model:

- Connecting dimensions: ISO 7005 / EN 1092 / DIN 2501 PN10 / BS4504
- With position indicator / Working pressure: both sides

d [mm]	DN [mm]	Inch	PN	kv-value ($\Delta p=1$ bar) [l/min]	PTFE/EPDM Code	kg
20	15	1/2	10	72	199 025 441	0.274
25	20	3/4	10	120	199 025 442	0.936
32	25	1	10	238	199 025 443	1.705
40	32	1 1/4	10	341	199 025 444	2.904
50	40	1 1/2	10	460	199 025 445	4.665
63	50	2	10	685	199 025 446	5.353

d [mm]	D [mm]	D1_G [inch]	D3[M] [mm]	D2 [mm]	L [mm]	L1 [mm]	L2 [mm]	H [mm]	H1 [mm]	H2 [mm]	H3 [mm]	H4 [mm]	H5 [mm]	H6 [mm]	H7 [mm]
20	96	3/8	6	95	130	60	25	125	69	25	23	44	100	155	56
25	96	3/8	6	105	150	60	25	127	71	25	23	44	100	155	56
32	120	1/2	6	115	160	60	25	163	93	26	36	64	100	155	68
40	150	1/4	8	140	180	60	45	196	106	36	36	64	100	160	85
50	180	1/4	8	150	200	60	45	227	119	37	36	64	100	170	101
63	180	1/4	8	165	230	60	45	241	133	37	36	64	100	170	101

d [mm]	H8 [mm]	H9 [mm]	H10 [mm]	Lift = Hx [mm]
20	86	14	12	8
25	88	18	12	10
32	100	21	12	12
40	117	26	15	14
50	133	33	15	18
63	133	39	15	22

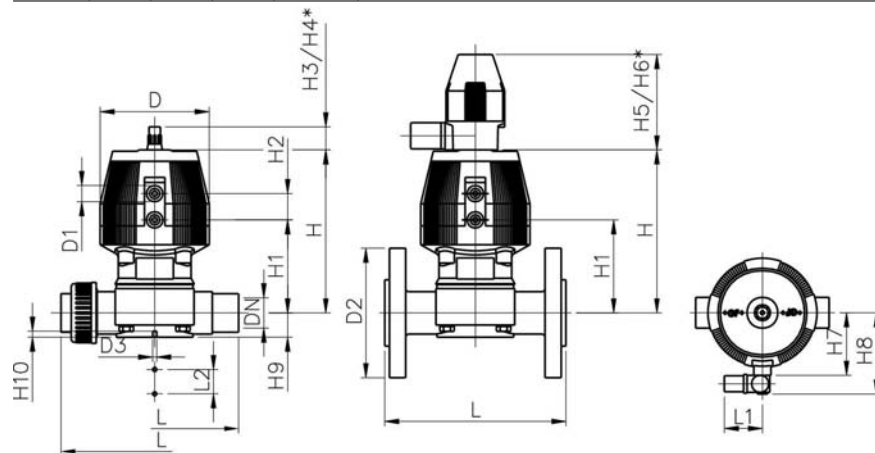

PF 3 39 212



SYGEF® PLUS

Diaphragm valve type DIASTAR 025

Function FC (Fail safe to close)

With fixed flanges PVDF metric

E

Model:

- Connecting dimensions: ISO 7005 / EN 1092 / DIN 2501 PN10 / BS4504
- With position indicator / Working pressure: both sides

* With backing flanges PP-V

** Connecting dimensions DN80 and DN150 metric and Inch ANSI B16.5

d [mm]	DN [mm]	Inch	PN	kv-value ($\Delta p=1$ bar) [l/min]	PTFE/EPDM Code	kg
*75	65	2 ½	10	992	199 025 447	13.600
**90	80	3	10	1700	199 025 448	17.400
110	100	4	8	2700	199 025 449	24.700

d [mm]	D [mm]	D1_G [inch]	D3[M] [mm]	D2 [mm]	D4 [mm]	L [mm]	L2 [mm]	H [mm]	H1 [mm]	H2 [mm]	H3 [mm]	H4 [mm]
*75	280	¼	8	185	145	290	70	344	148	24	46	100
**90	280	¼	12	200	160	310	120	348	150	24	46	100
110	335	¼	12	225	180	350	120	395	176	24	46	100

d [mm]	H5 [mm]	H6 [mm]	H7 [mm]	H9 [mm]	H10 [mm]
*75	129	195	298	46	15
**90	129	195	302	57	15
110	129	195	349	69	20

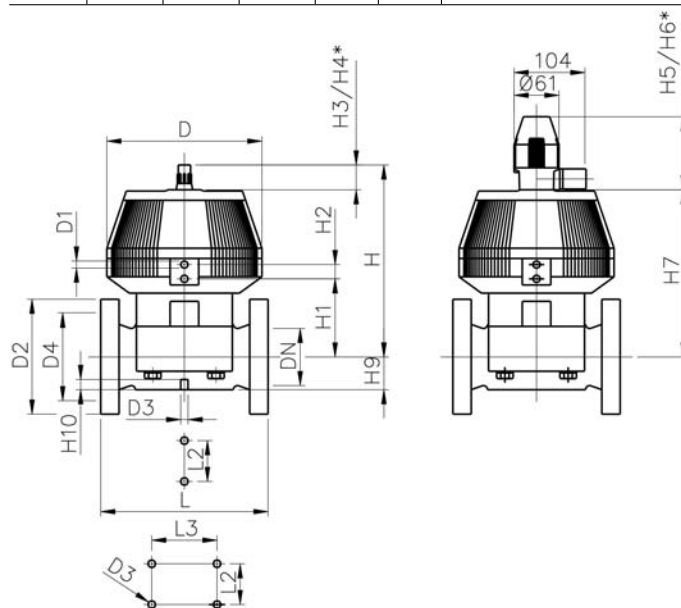

PF 3 39 212



SYGEF® PLUS

Diaphragm valve type DIASTAR 025

Function FC (Fail safe to close)

With backing flanges PP-V ANSI

E

Model:

- Overall length according to EN 558-1
- Connecting dimension: ANSI B 16.5 class 150 (ASTM D 4024), BS EN 1759
- With position indicator / Working pressure: both sides

Inch	DN [mm]	PN	kv-value ($\Delta p=1$ bar) [l/min]	PTFE/EPDM Code	kg
1/2	15	10	72	199 027 581	0.274
3/4	20	10	120	199 027 582	
1	25	10	238	199 027 583	1.705
1 1/4	32	10	341	199 027 584	2.904
1 1/2	40	10	460	199 027 585	
2	50	10	685	199 027 586	

Inch	D [mm]	D1_G [inch]	D3[M] [mm]	D2 [mm]	L [mm]	L1 [mm]	L2 [mm]	H [mm]	H1 [mm]	H2 [mm]	H3 [mm]	H4 [mm]	H5 [mm]	H6 [mm]
1/2	96	1/8	6	95	130	60	25	125	69	25	23	44	100	155
3/4	96	1/8	6	105	150	60	25	127	71	25	23	44	100	155
1	120	1/8	6	115	160	60	25	163	93	26	36	64	100	155
1 1/4	150	1/4	8	140	180	60	45	196	106	36	36	64	100	160
1 1/2	180	1/4	8	150	200	60	45	227	119	37	36	64	100	170
2	180	1/4	8	165	230	60	45	241	133	37	36	64	100	170

Inch	H7 [mm]	H8 [mm]	H9 [mm]	H10 [mm]	Lift = Hx [mm]
1/2	56	86	14	12	8
3/4	56	88	18	12	10
1	68	100	21	12	12
1 1/4	85	117	26	15	14
1 1/2	101	133	33	15	18
2	101	133	39	15	22

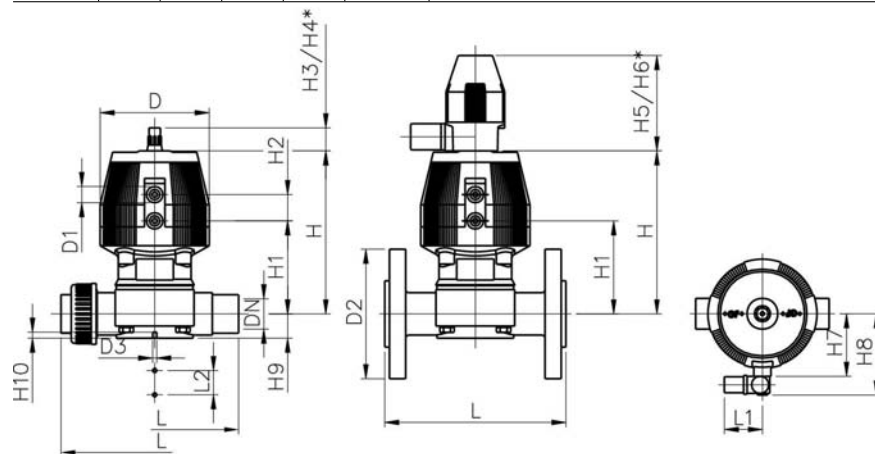

PF 3 39 212



SYGEF® PLUS

Diaphragm valve type DIASTAR 025

Function FC (Fail safe to close)

With fixed flanges PVDF ANSI

E

Model:

- Overall length according to EN 558-1
- Connecting dimension: ANSI B 16.5 class 150 (ASTM D 4024), BS EN 1759
- With position indicator / Working pressure: both sides

* With backing flanges PP-V

** Connecting dimensions DN80 and DN150 metric and Inch ANSI B16.5

Inch	DN [mm]	PN	kv-value ($\Delta p=1$ bar) [l/min]	PTFE/EPDM Code	kg
*2 1/2	65	10	992	199 025 387	14.200
**3	80	10	1700	199 025 448	17.400
4	100	8	2700	199 025 389	26.500

Inch	D [mm]	D1_G [inch]	D3[M] [mm]	D2 [mm]	D4 [mm]	L [mm]	L2 [mm]	H [mm]	H1 [mm]	H2 [mm]	H3 [mm]	H4 [mm]
*2 1/2	280	1/4	8	185	145	290	70	344	148	24	46	100
**3	280	1/4	12	200	160	310	120	348	150	24	46	100
4	335	1/4	12	225	180	350	120	395	176	24	46	100

Inch	H5 [mm]	H6 [mm]	H7 [mm]	H9 [mm]	H10 [mm]
*2 1/2	129	195	298	46	15
**3	129	195	302	57	15
4	129	195	349	69	20

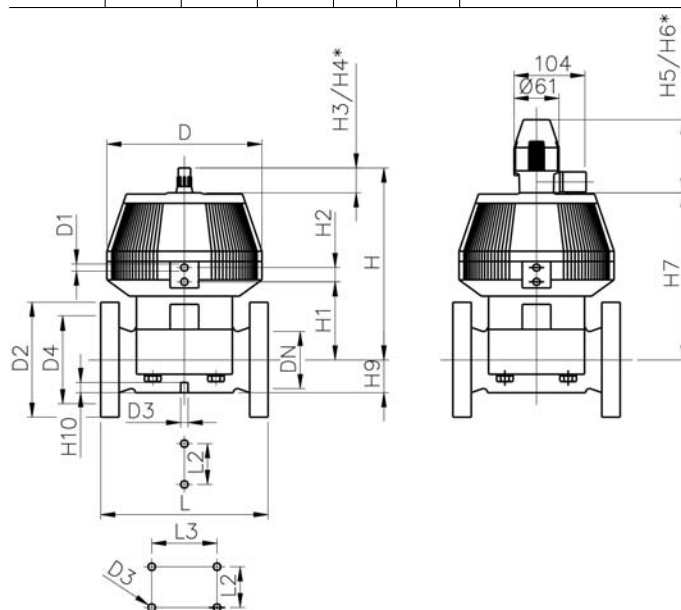

PF 3 39 212



SYGEF® PLUS
Diaphragm valve type DIASTAR 025
Function FC (Fail safe to close)
ZERO STATIC with butt fusion spigots ISO/DIN

E

- With position indicator / Working pressure: both sides
- With position indicator
- DN2: for coordination of accessoires

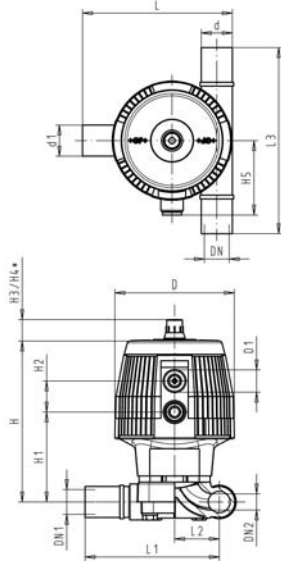

d	d1	DN	DN1	DN2	PN	kv-value ($\Delta p=1$ bar) [l/min]	PTFE Code	kg
20	20	15	15	15	10	47	199 029 341	1.564
25	20	20	15	20	10	69	199 029 342	1.097
25	25	20	20	20	10	91	199 029 343	1.096
32	20	25	15	25	10	86	199 029 344	2.701
32	25	25	20	25	10	126	199 029 345	2.698
32	32	25	25	25	10	156	199 029 346	2.696
40	20	32	15	25	10	84	199 029 347	2.772
40	25	32	20	25	10	124	199 029 348	2.773
40	32	32	25	25	10	161	199 029 349	2.773
40	40	32	32	32	10	250	199 029 350	3.093
50	20	40	15	25	10	82	199 029 351	2.813
50	25	40	20	25	10	124	199 029 352	2.812
50	32	40	25	25	10	159	199 029 353	2.808
50	40	40	32	40	10	312	199 029 354	5.107
50	50	40	40	40	10	356	199 029 355	5.104
63	20	50	15	25	10	81	199 029 356	2.877
63	25	50	20	25	10	115	199 029 357	2.873
63	32	50	25	25	10	156	199 029 358	2.872
63	40	50	32	50	10	383	199 029 359	6.073
63	50	50	40	50	10	487	199 029 360	6.071
63	63	50	50	50	10	544	199 029 361	6.070
75	40	65	32	32	10	256	199 029 362	3.368
75	50	65	40	50	10	497	199 029 363	6.223
75	63	65	50	50	10	546	199 029 364	6.231
90	20	80	15	25	10	88	199 029 365	3.042
90	25	80	20	25	10	133	199 029 366	2.655
90	32	80	25	25	10	162	199 029 367	3.033
90	50	80	40	50	10	504	199 029 368	6.347
90	63	80	50	50	10	530	199 029 369	6.347
110	20	100	15	25	10	89	199 029 370	3.228
110	25	100	20	25	10	123	199 029 371	3.226
110	32	100	25	25	10	159	199 029 372	3.223
110	50	100	40	50	10	503	199 029 373	6.639
110	63	100	50	50	10	543	199 029 374	6.624

d	L	L1	L2	L3	H	H1	H2	H3	H4	H5	D	D1	Lift = Hx
[mm]	[mm]	[mm]	[mm]	[mm]	[mm]	[mm]	[mm]	[mm]	[mm]	[mm]	[mm]	[inch]	[mm]
20	106	96	30	140	128	69	25	23	44	56	96	3/8	8
25	121	108	36	150	130	71	25	23	44	56	96	3/8	10
25	121	108	36	150	130	71	25	23	44	56	96	3/8	10
32	137	120	43	160	166	93	26	36	64	68	120	1/2	12
32	137	120	43	160	166	93	26	36	64	68	120	1/2	12
32	137	120	43	160	166	93	26	36	64	68	120	1/2	12
40	149	128	51	180	166	93	26	36	64	68	120	1/2	12
40	149	128	51	180	166	93	26	36	64	68	120	1/2	12
40	149	128	51	180	166	93	26	36	64	68	120	1/2	12
40	149	128	51	180	166	93	26	36	64	68	120	1/2	12
40	174	153	56	190	201	106	36	36	64	85	150	1/2	14
50	159	134	57	180	166	93	26	36	64	68	120	1/2	12
50	159	134	57	180	166	93	26	36	64	68	120	1/2	12
50	159	134	57	180	166	93	26	36	64	68	120	1/2	12
50	195	169	66	200	233	119	37	36	64	101	180	3/4	18
50	195	169	66	200	233	119	37	36	64	101	180	3/4	18
63	175	144	67	180	166	93	26	36	64	68	120	1/2	12
63	175	144	67	180	166	93	26	36	64	68	120	1/2	12
63	175	144	67	180	166	93	26	36	64	68	120	1/2	12

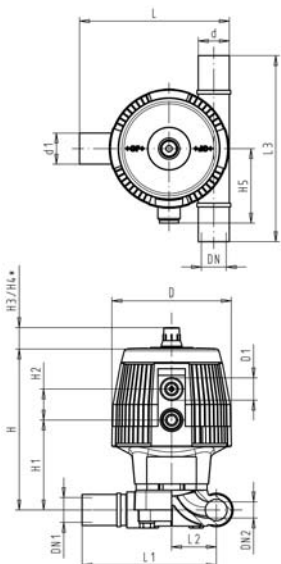

d [mm]	L [mm]	L1 [mm]	L2 [mm]	L3 [mm]	H [mm]	H1 [mm]	H2 [mm]	H3 [mm]	H4 [mm]	H5 [mm]	D [mm]	D1 [inch]	Lift = Hx [mm]
63	223	192	80	220	247	133	37	36	64	101	180	¼	22
63	225	192	80	220	247	133	37	36	64	101	180	¼	22
63	223	192	80	220	247	133	37	36	64	101	180	¼	22
75	203	166	78	190	201	106	36	36	64	85	150	⅜	14
75	236	198	86	220	247	133	37	36	64	101	180	¼	22
75	236	198	86	220	247	133	37	36	64	101	180	¼	22
90	204	159	82	160	166	93	26	36	64	68	120	⅜	12
90	204	159	82	160	166	93	26	36	64	68	120	⅜	12
90	204	159	82	160	166	93	26	36	64	68	120	⅜	12
90	252	207	95	220	247	133	37	36	64	101	180	¼	22
90	252	207	95	220	247	133	37	36	64	101	180	¼	22
110	226	171	94	160	166	93	26	36	64	68	120	⅜	12
110	226	171	94	160	166	93	26	36	64	68	120	⅜	12
110	226	171	94	160	166	93	26	36	64	68	120	⅜	12
110	274	219	107	220	247	133	37	36	64	101	180	¼	22
110	274	219	107	220	247	133	37	36	64	101	180	¼	22

PF 3 39 212



SYGEF® PLUS
Diaphragm valve type DIASTAR 025
Function FC (Fail safe to close)
With butt fusion spigots IR metric HTR

- With position indicator / Working pressure: both sides for correct clamping and fusion jointing of flange adapters

d [mm]	DN [mm]	PN	kv-value ($\Delta p=1$ bar) [l/min]	PTFE/EPDM Code	kg
20	15	6	72	199 027 731	0.839
25	20	6	120	199 027 732	0.936
32	25	6	238	199 027 733	1.705
40	32	10	341	199 027 734	2.904
50	40	10	460	199 027 735	4.665
63	50	10	685	199 027 736	5.353

d [mm]	D [mm]	D1_G [inch]	D3[M] [mm]	L [mm]	L1 [mm]	L2 [mm]	H [mm]	H1 [mm]	H2 [mm]	H3 [mm]	H4 [mm]	H5 [mm]	H6 [mm]	H7 [mm]	H8 [mm]
20	96	1/8	6	124	60	25	125	69	25	23	44	100	155	56	86
25	96	1/8	6	144	60	25	127	71	25	23	44	100	155	56	88
32	120	1/8	6	154	60	25	163	93	26	36	64	100	155	68	100
40	150	1/4	8	174	60	45	196	106	36	36	64	100	160	85	117
50	180	1/4	8	194	60	45	227	119	37	36	64	100	170	101	133
63	180	1/4	8	224	60	45	241	133	37	36	64	100	170	101	133

d [mm]	H9 [mm]	H10 [mm]	Lift = Hx [mm]
20	14	12	8
25	18	12	10
32	21	12	12
40	26	15	14
50	33	15	18
63	39	15	22

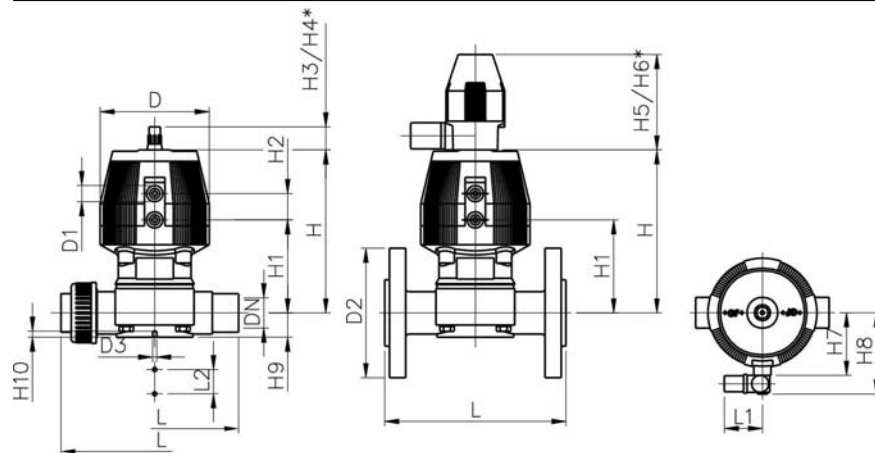

PF 3 39 212



SYGEF® PLUS

Diaphragm valve type DIASTAR 025

Function FC (Fail safe to close)

Unions with fusion spigots metric HTR

- With position indicator / Working pressure: both sides for correct clamping and fusion jointing of flange adapters

d [mm]	DN [mm]	PN	kv-value ($\Delta p=1$ bar) [l/min]	PTFE/EPDM Code	kg
20	15	10	72	199 027 771	0.936
25	20	10	120	199 027 772	
32	25	10	238	199 027 773	
40	32	10	341	199 027 774	
50	40	10	460	199 027 775	
63	50	10	685	199 027 776	

d [mm]	D [mm]	D1_G [inch]	D3[M] [mm]	L [mm]	L1 [mm]	L2 [mm]	H [mm]	H1 [mm]	H2 [mm]	H3 [mm]	H4 [mm]	H5 [mm]	H6 [mm]	H7 [mm]	H8 [mm]
20	96	1/8	6	225	60	25	125	69	25	23	44	100	155	56	86
25	96	1/8	6	242	60	25	127	71	25	23	44	100	155	56	88
32	120	1/8	6	254	60	25	163	93	26	36	64	100	155	68	100
40	150	1/4	8	308	60	45	196	106	36	36	64	100	160	85	117
50	180	1/4	8	330	60	45	227	119	37	36	64	100	170	101	133
63	180	1/4	8	373	60	45	241	133	37	36	64	100	170	101	133

d [mm]	H9 [mm]	H10 [mm]	Lift = Hx [mm]
20	14	12	8
25	18	12	10
32	21	12	12
40	26	15	14
50	33	15	18
63	39	15	22

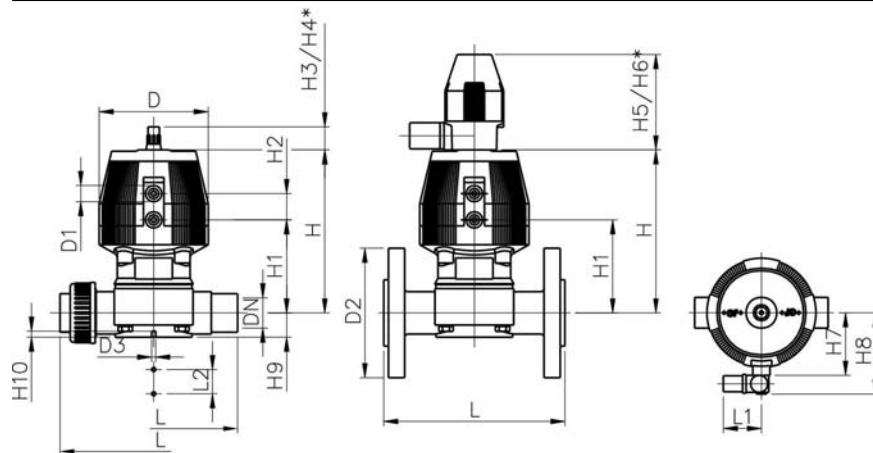

PF 3 39 212



SYGEF® PLUS

Diaphragm valve type DIASTAR 025

Function FC (Fail safe to close)

ZERO STATIC with butt fusion spigots metric HTR

- With position indicator / Working pressure: both sides for correct clamping and fusion jointing of flange adapters

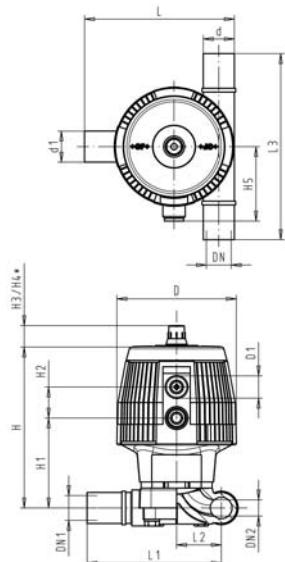

d [mm]	d1 [mm]	DN [mm]	DN1 [mm]	DN2 [mm]	PN	kv-value ($\Delta p=1$ bar) [l/min]	PTFE/EPDM Code	kg
20	20	15	15	15	10	47	199 027 811	0.900
25	20	20	15	20	10	69	199 027 812	
25	25	20	20	20	10	91	199 027 813	
32	20	25	15	25	10	86	199 027 814	
32	25	25	20	25	10	126	199 027 815	2.696
32	32	25	25	25	10	156	199 027 816	
40	20	32	15	25	10	84	199 027 817	
40	25	32	20	25	10	124	199 027 818	
40	32	32	25	25	10	161	199 027 819	3.093
40	40	32	32	32	10	250	199 027 820	
50	20	40	15	25	10	82	199 027 821	
50	25	40	20	25	10	124	199 027 822	
50	32	40	25	25	10	159	199 027 823	1.500
50	40	40	32	40	10	312	199 027 824	
50	50	40	40	40	10	356	199 027 825	
63	20	50	15	25	10	81	199 027 826	
63	25	50	20	25	10	115	199 027 827	
63	32	50	25	25	10	156	199 027 828	
63	40	50	32	50	10	383	199 027 829	
63	50	50	40	50	10	487	199 027 830	
63	63	50	50	50	10	544	199 027 831	
75	40	65	32	32	10	256	199 027 832	
75	50	65	40	50	10	497	199 027 833	
75	63	65	50	50	10	546	199 027 834	
90	20	80	15	25	10	88	199 027 835	
90	25	80	20	25	10	133	199 027 836	
90	32	80	25	25	10	162	199 027 837	
90	50	80	40	50	10	504	199 027 838	
90	63	80	50	50	10	530	199 027 839	
110	20	100	15	25	10	89	199 027 840	
110	25	100	20	25	10	123	199 027 841	
110	32	100	25	25	10	159	199 027 842	
110	50	100	40	50	10	503	199 027 843	
110	63	100	50	50	10	543	199 027 844	

d [mm]	L [mm]	L1 [mm]	L2 [mm]	L3 [mm]	H [mm]	H1 [mm]	H2 [mm]	H3 [mm]	H4 [mm]	H5 [mm]	D [mm]	D1 [inch]	Lift = Hx [mm]
20	106	96	30	140	128	69	25	23	44	56	96	1/8	8
25	121	108	36	150	130	71	25	23	44	56	96	1/8	10
25	121	108	36	150	130	71	25	23	44	56	96	1/8	10
32	137	120	43	160	166	93	26	36	64	68	120	1/8	12
32	137	120	43	160	166	93	26	36	64	68	120	1/8	12
32	137	120	43	160	166	93	26	36	64	68	120	1/8	12
40	149	128	51	180	166	93	26	36	64	68	120	1/8	12
40	149	128	51	180	166	93	26	36	64	68	120	1/8	12
40	149	128	51	180	166	93	26	36	64	68	120	1/8	12
40	174	153	56	190	201	106	36	36	64	85	150	1/8	14
50	159	134	57	180	166	93	26	36	64	68	120	1/8	12
50	159	134	57	180	166	93	26	36	64	68	120	1/8	12
50	159	134	57	180	166	93	26	36	64	68	120	1/8	12
50	195	169	66	200	233	119	37	36	64	101	180	1/4	18
50	195	169	66	200	233	119	37	36	64	101	180	1/4	18
63	175	144	67	180	166	93	26	36	64	68	120	1/8	12
63	175	144	67	180	166	93	26	36	64	68	120	1/8	12
63	175	144	67	180	166	93	26	36	64	68	120	1/8	12
63	223	192	80	220	247	133	37	36	64	101	180	1/4	22
63	225	192	80	220	247	133	37	36	64	101	180	1/4	22

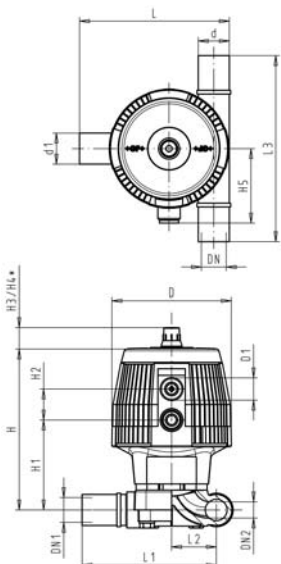

d [mm]	L [mm]	L1 [mm]	L2 [mm]	L3 [mm]	H [mm]	H1 [mm]	H2 [mm]	H3 [mm]	H4 [mm]	H5 [mm]	D [mm]	D1 [inch]	Lift = Hx [mm]
63	223	192	80	220	247	133	37	36	64	101	180	¼	22
75	203	166	78	190	201	106	36	36	64	85	150	⅛	14
75	236	198	86	220	247	133	37	36	64	101	180	¼	22
75	236	198	86	220	247	133	37	36	64	101	180	¼	22
90	204	159	82	160	166	93	26	36	64	68	120	⅛	12
90	204	159	82	160	166	93	26	36	64	68	120	⅛	12
90	204	159	82	160	166	93	26	36	64	68	120	⅛	12
90	252	207	95	220	247	133	37	36	64	101	180	¼	22
90	252	207	95	220	247	133	37	36	64	101	180	¼	22
110	226	171	94	160	166	93	26	36	64	68	120	⅛	12
110	226	171	94	160	166	93	26	36	64	68	120	⅛	12
110	226	171	94	160	166	93	26	36	64	68	120	⅛	12
110	274	219	107	220	247	133	37	36	64	101	180	¼	22
110	274	219	107	220	247	133	37	36	64	101	180	¼	22

PF 3 39 212



SYGEF® PLUS
Diaphragm valve type DIASTAR 025
Function FO (Fail safe to open)
With butt fusion spigots IR metric

E

- With position indicator / Working pressure: both sides

d [mm]	DN [mm]	PN	kv-value ($\Delta p=1$ bar) [l/min]	PTFE/EPDM Code	kg
20	15	10	72	199 025 977	0.454
25	20	10	120	199 025 978	0.740
32	25	10	238	199 025 979	1.160
40	32	10	341	199 025 980	1.390
50	40	10	460	199 025 981	2.510
63	50	10	685	199 025 982	5.430

d [mm]	D [mm]	D1_G [inch]	D3[M] [mm]	L [mm]	L1 [mm]	L2 [mm]	H [mm]	H1 [mm]	H2 [mm]	H3 [mm]	H4 [mm]	H5 [mm]	H6 [mm]	H7 [mm]	H8 [mm]
20	68	1/8	6	124	60	25	98	59	24	23	44	100	155	44	76
25	96	1/8	6	144	60	25	127	71	25	23	44	100	155	56	88
32	96	1/8	6	154	60	25	141	85	25	23	44	100	155	56	88
40	120	1/8	8	174	60	45	167	97	26	36	64	100	160	68	100
50	150	1/4	8	194	60	45	198	108	36	36	64	100	170	85	117
63	150	1/4	8	224	60	45	216	126	36	36	64	100	170	85	117

d [mm]	H9 [mm]	H10 [mm]	Lift = Hx [mm]
20	14	12	8
25	18	12	10
32	21	12	12
40	26	15	14
50	33	15	18
63	39	15	22

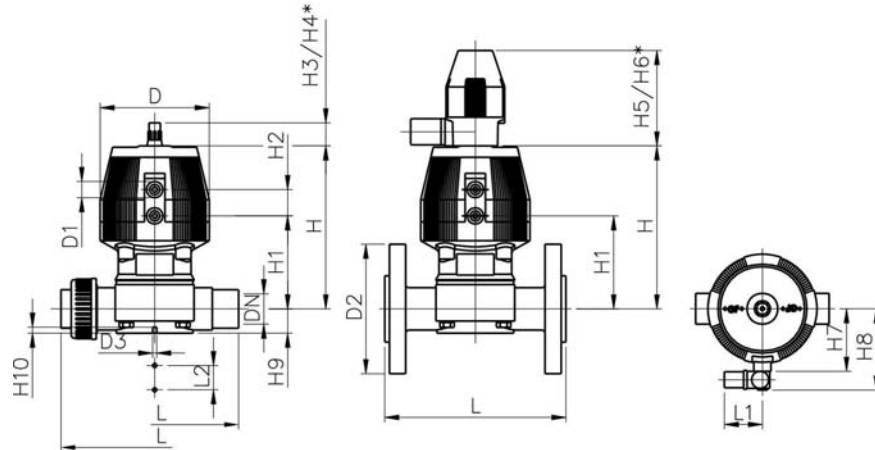

PF 3 39 212



SYGEF® PLUS

Diaphragm valve type DIASTAR 025

Function FO (Fail safe to open)

Unions with fusion spigots metric

E

- With position indicator / Working pressure: both sides

d [mm]	DN [mm]	PN	kv-value ($\Delta p=1$ bar) [l/min]	PTFE/EPDM Code	kg
20	15	10	72	199 027 411	0.839
25	20	10	120	199 027 412	0.936
32	25	10	238	199 027 413	1.705
40	32	10	341	199 027 414	2.370
50	40	10	460	199 027 415	2.510
63	50	10	685	199 027 416	5.430

d [mm]	D [mm]	D1_G [inch]	D3[M] [mm]	L [mm]	L1 [mm]	L2 [mm]	H [mm]	H1 [mm]	H2 [mm]	H3 [mm]	H4 [mm]	H5 [mm]	H6 [mm]	H7 [mm]	H8 [mm]
20	68	1/8	6	225	60	25	98	59	24	23	44	100	155	44	76
25	96	1/8	6	242	60	25	127	71	25	23	44	100	155	56	88
32	96	1/8	6	254	60	25	141	85	25	23	44	100	155	56	88
40	120	1/8	8	308	60	45	167	97	26	36	64	100	160	68	100
50	150	1/4	8	330	60	45	198	108	36	36	64	100	170	85	117
63	150	1/4	8	373	60	45	216	126	36	36	64	100	170	85	117

d [mm]	H9 [mm]	H10 [mm]	Lift = Hx [mm]
20	14	12	8
25	18	12	10
32	21	12	12
40	26	15	14
50	33	15	18
63	39	15	22

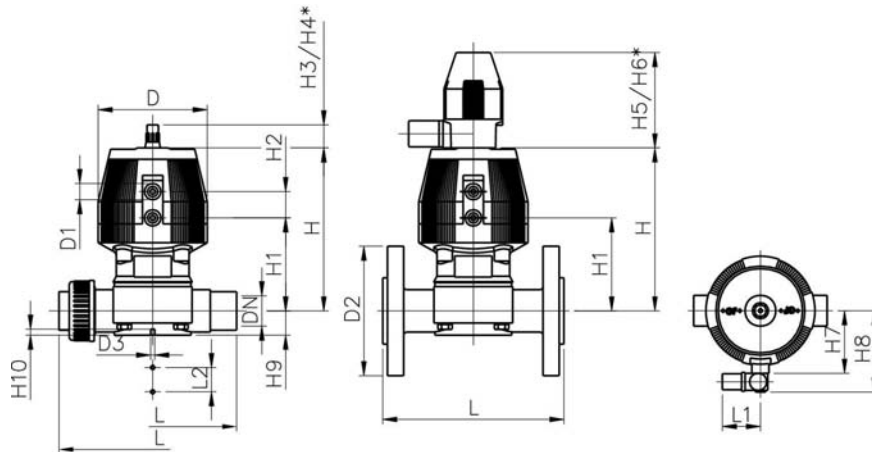

PF 3 39 212



SYGEF® PLUS

Diaphragm valve type DIASTAR 025

Function FO (Fail safe to open)

With backing flanges PP-V metric

E

Model:

- Connecting dimensions: ISO 7005 / EN 1092 / DIN 2501 PN10 / BS4504
- With position indicator / Working pressure: both sides

d [mm]	DN [mm]	Inch	PN	kv-value ($\Delta p=1$ bar) [l/min]	PTFE/EPDM Code	kg
20	15	1/2	10	72	199 025 451	0.824
25	20	3/4	10	120	199 025 452	1.090
32	25	1	10	238	199 025 453	1.610
40	32	1 1/4	10	341	199 025 454	1.950
50	40	1 1/2	10	460	199 025 455	3.010
63	50	2	10	685	199 025 456	5.510

d [mm]	D [mm]	D1_G [inch]	D3[M] [mm]	D2 [mm]	L [mm]	L1 [mm]	L2 [mm]	H [mm]	H1 [mm]	H2 [mm]	H3 [mm]	H4 [mm]	H5 [mm]	H6 [mm]	H7 [mm]
20	68	1/8	6	95	130	60	25	98	59	24	23	44	100	155	44
25	96	1/8	6	105	150	60	25	127	71	25	23	44	100	155	56
32	96	1/8	6	115	160	60	25	141	85	25	23	44	100	155	56
40	120	1/8	8	140	180	60	45	167	97	26	36	64	100	160	68
50	150	1/4	8	150	200	60	45	198	108	36	36	64	100	170	85
63	150	1/4	8	165	230	60	45	216	126	36	36	64	100	170	85

d [mm]	H8 [mm]	H9 [mm]	H10 [mm]	Lift = Hx [mm]
20	76	14	12	8
25	88	18	12	10
32	88	21	12	12
40	100	26	15	14
50	117	33	15	18
63	117	39	15	22

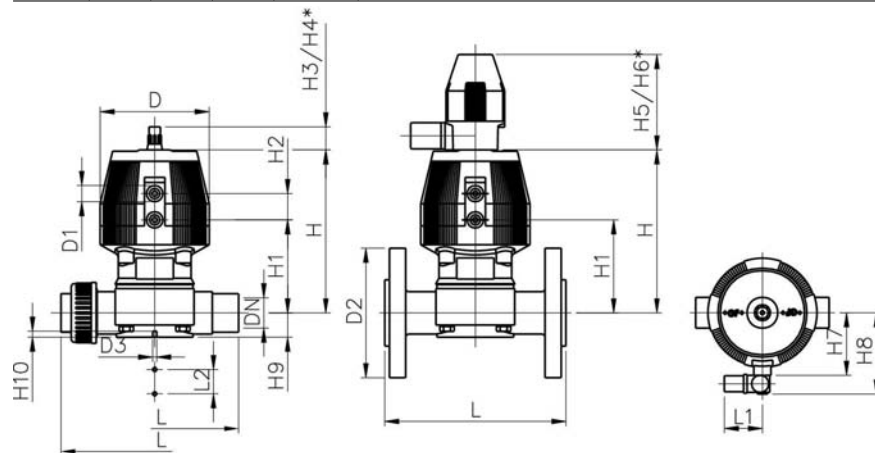

PF 3 39 212



SYGEF® PLUS

Diaphragm valve type DIASTAR 025

Function FO (Fail safe to open)

With fixed flanges PVDF metric

E

Model:

- Connecting dimensions: ISO 7005 / EN 1092 / DIN 2501 PN10 / BS4504
- With position indicator / Working pressure: on one side

* With backing flanges PP-V

** Connecting dimensions DN80 and DN150 metric and Inch ANSI B16.5

d [mm]	DN [mm]	Inch	PN	kv-value ($\Delta p=1$ bar) [l/min]	PTFE/EPDM Code	kg
*75	65	2 ½	10	992	199 025 457	13.600
**90	80	3	10	1700	199 025 458	17.400
110	100	4	8	2700	199 025 459	24.700
**160	150	6	6	6033	199 025 460	35.000

d [mm]	D [mm]	D1_G [inch]	D3[M] [mm]	D2 [mm]	D4 [mm]	L [mm]	L2 [mm]	L3 [mm]	H [mm]	H1 [mm]	H2 [mm]	H3 [mm]
*75	280	¼	8	185	145	290	70		344	148	24	46
**90	280	¼	12	200	160	310	120		348	150	24	46
110	335	¼	12	225	180	350	120		395	176	24	46
**160	335	¼	12	285	240	480	100	200	455	237	24	46

d [mm]	H4 [mm]	H5 [mm]	H6 [mm]	H7 [mm]	H9 [mm]	H10 [mm]
*75	100	129	195	298	46	15
**90	100	129	195	302	57	15
110	100	129	195	349	69	20
**160	100	129	195	409	108	20

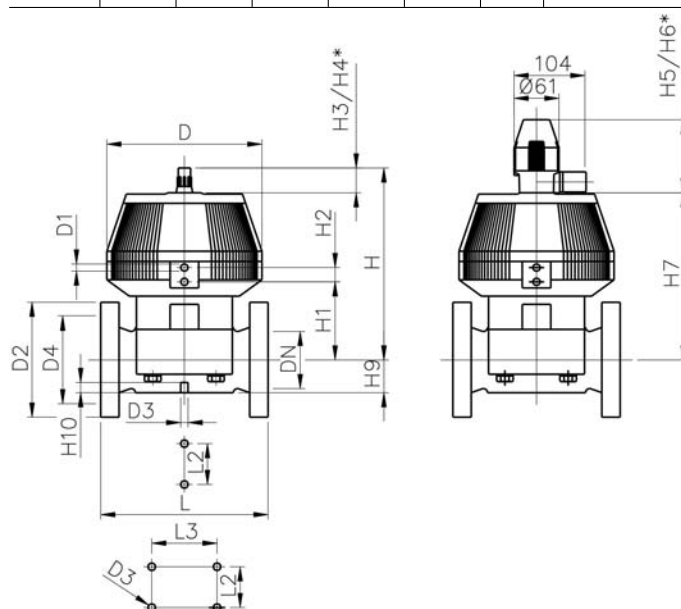

PF 3 39 212



SYGEF® PLUS

Diaphragm valve type DIASTAR 025

Function FO (Fail safe to open)

With backing flanges PP-V ANSI

E

Model:

- Overall length according to EN 558-1
- Connecting dimension: ANSI B 16.5 class 150 (ASTM D 4024), BS EN 1759
- With position indicator / Working pressure: both sides

Inch	DN [mm]	PN	kv-value ($\Delta p=1$ bar) [l/min]	PTFE/EPDM Code
1/2	15	10	72	199 027 591
3/4	20	10	120	199 027 592
1	25	10	238	199 027 593
1 1/4	32	10	341	199 027 594
1 1/2	40	10	460	199 027 595
2	50	10	685	199 027 596

Inch	D [mm]	D1_G [inch]	D3[M] [mm]	D2 [mm]	L [mm]	L1 [mm]	L2 [mm]	H [mm]	H1 [mm]	H2 [mm]	H3 [mm]	H4 [mm]	H5 [mm]	H6 [mm]
1/2	68	1/8	6	95	130	60	25	98	59	24	23	44	100	155
3/4	96	1/8	6	105	150	60	25	127	71	25	23	44	100	155
1	96	1/8	6	115	160	60	25	141	85	25	23	44	100	155
1 1/4	120	1/8	8	140	180	60	45	167	97	26	36	64	100	160
1 1/2	150	1/4	8	150	200	60	45	198	108	36	36	64	100	170
2	150	1/4	8	165	230	60	45	216	126	36	36	64	100	170

Inch	H7 [mm]	H8 [mm]	H9 [mm]	H10 [mm]	Lift = Hx [mm]
1/2	44	76	14	12	8
3/4	56	88	18	12	10
1	56	88	21	12	12
1 1/4	68	100	26	15	14
1 1/2	85	117	33	15	18
2	85	117	39	15	22

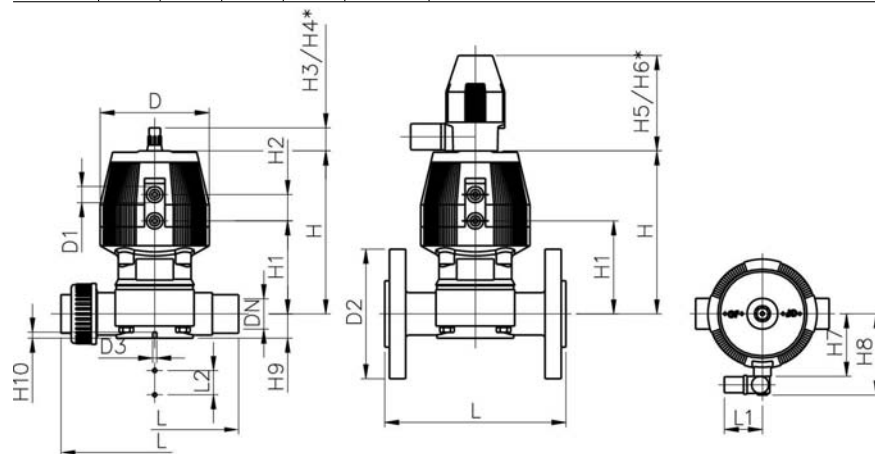

PF 3 39 212



SYGEF® PLUS

Diaphragm valve type DIASTAR 025

Function FO (Fail safe to open)

With fixed flanges PVDF ANSI

E

Model:

- Overall length according to EN 558-1
- Connecting dimension: ANSI B 16.5 class 150 (ASTM D 4024), BS EN 1759
- With position indicator / Working pressure: on one side

* With backing flanges PP-V

** Connecting dimensions DN80 and DN150 metric and Inch ANSI B16.5

Inch	DN [mm]	PN	kv-value ($\Delta p=1$ bar) [l/min]	PTFE/EPDM Code	kg							
*2 ½	65	10	992	199 025 397	12.200							
**3	80	10	1700	199 025 458	17.400							
4	100	8	2700	199 025 399	23.400							
**6	150	6	6033	199 025 460	35.000							

Inch	D [mm]	D1_G [inch]	D3[M] [mm]	D2 [mm]	D4 [mm]	L [mm]	L2 [mm]	L3 [mm]	H [mm]	H1 [mm]	H2 [mm]	H3 [mm]
*2 ½	280	¼	8	185	145	290	70		344	148	24	46
**3	280	¼	12	200	160	310	120		348	150	24	46
4	335	¼	12	225	180	350	120		395	176	24	46
**6	335	¼	12	285	240	480	100	200	455	237	24	46

Inch	H4 [mm]	H5 [mm]	H6 [mm]	H7 [mm]	H9 [mm]	H10 [mm]
*2 ½	100	129	195	298	46	15
**3	100	129	195	302	57	15
4	100	129	195	349	69	20
**6	100	129	195	409	108	20

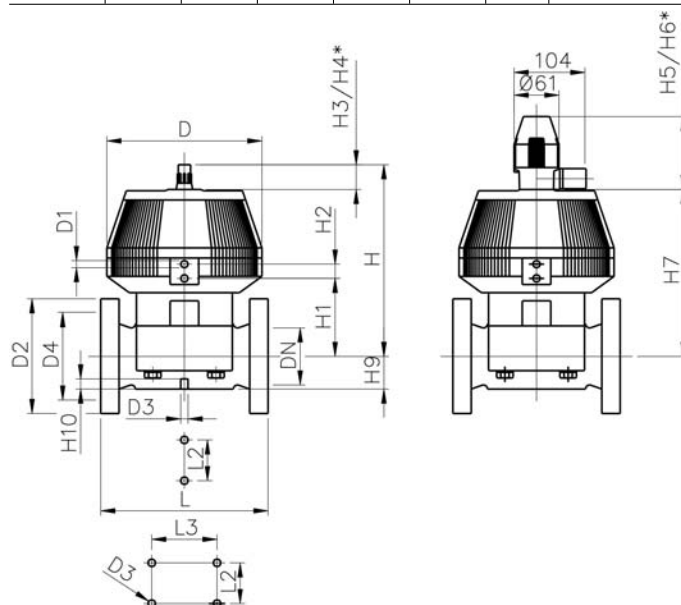

PF 3 39 212



SYGEF® PLUS
Diaphragm valve type DIASTAR 025
Function FO (Fail safe to open)
With butt fusion spigots IR metric HTR

- With position indicator / Working pressure: both sides for correct clamping and fusion jointing of flange adapters

d [mm]	DN [mm]	PN	kv-value ($\Delta p=1$ bar) [l/min]	PTFE/EPDM Code	kg
20	15	10	72	199 027 741	0.839
25	20	10	120	199 027 742	0.839
32	25	10	238	199 027 743	1.160
40	32	10	341	199 027 744	1.390
50	40	10	460	199 027 745	2.510
63	50	10	685	199 027 746	5.430

d [mm]	D [mm]	D1_G [inch]	D3[M] [mm]	L [mm]	L1 [mm]	L2 [mm]	H [mm]	H1 [mm]	H2 [mm]	H3 [mm]	H4 [mm]	H5 [mm]	H6 [mm]	H7 [mm]	H8 [mm]
20	68	1/8	6	124	60	25	98	59	24	23	44	100	155	44	76
25	96	1/8	6	144	60	25	127	71	25	23	44	100	155	56	88
32	96	1/8	6	154	60	25	141	85	25	23	44	100	155	56	88
40	120	1/8	8	174	60	45	167	97	26	36	64	100	160	68	100
50	150	1/4	8	194	60	45	198	108	36	36	64	100	170	85	117
63	150	1/4	8	224	60	45	216	126	36	36	64	100	170	85	117

d [mm]	H9 [mm]	H10 [mm]	Lift = Hx [mm]
20	14	12	8
25	18	12	10
32	21	12	12
40	26	15	14
50	33	15	18
63	39	15	22

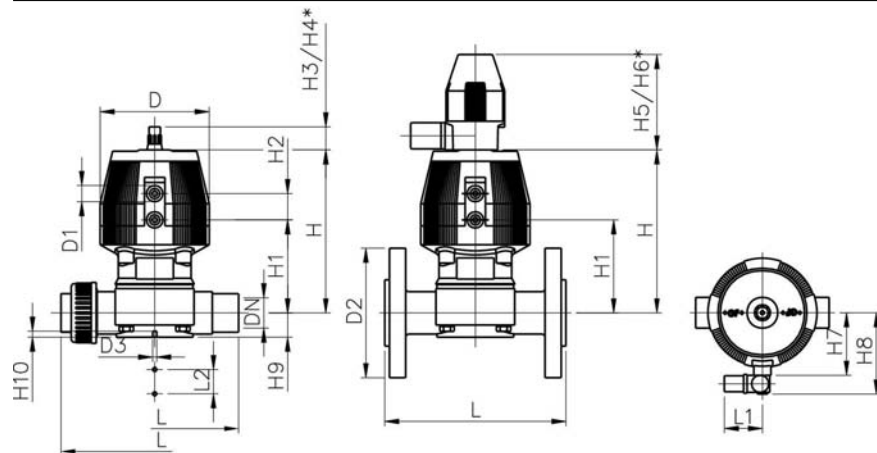

PF 3 39 212



SYGEF® PLUS

Diaphragm valve type DIASTAR 025

Function FO (Fail safe to open)

Unions with fusion spigots metric HTR

- With position indicator / Working pressure: both sides for correct clamping and fusion jointing of flange adapters

d [mm]	DN [mm]	PN	kv-value ($\Delta p=1$ bar) [l/min]	PTFE/EPDM Code	kg
20	15	10	72	199 027 781	0.936
25	20	10	120	199 027 782	
32	25	10	238	199 027 783	
40	32	10	341	199 027 784	
50	40	10	460	199 027 785	
63	50	10	685	199 027 786	

d [mm]	D [mm]	D1_G [inch]	D3[M] [mm]	L [mm]	L1 [mm]	L2 [mm]	H [mm]	H1 [mm]	H2 [mm]	H3 [mm]	H4 [mm]	H5 [mm]	H6 [mm]	H7 [mm]	H8 [mm]
20	68	1/8	6	225	60	25	98	59	24	23	44	100	155	44	76
25	96	1/8	6	242	60	25	127	71	25	23	44	100	155	56	88
32	96	1/8	6	254	60	25	141	85	25	23	44	100	155	56	88
40	120	1/8	8	308	60	45	167	97	26	36	64	100	160	68	100
50	150	1/4	8	330	60	45	198	108	36	36	64	100	170	85	117
63	150	1/4	8	373	60	45	216	126	36	36	64	100	170	85	117

d [mm]	H9 [mm]	H10 [mm]	Lift = Hx [mm]
20	14	12	8
25	18	12	10
32	21	12	12
40	26	15	14
50	33	15	18
63	39	15	22

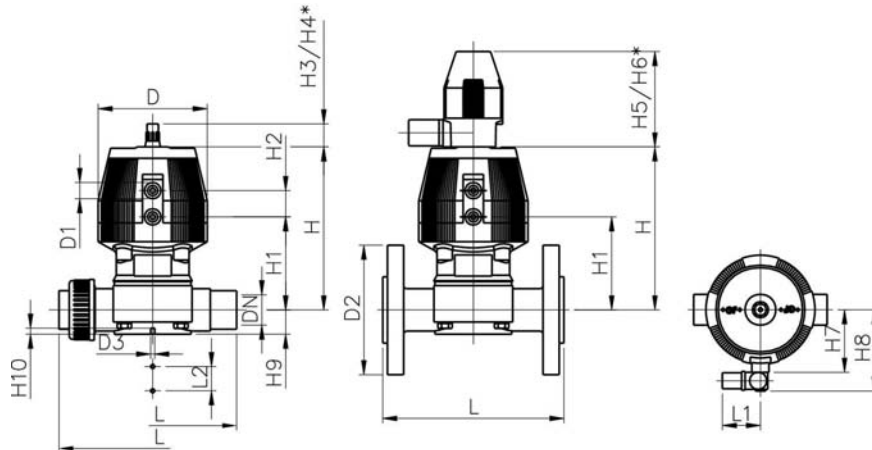

PF 3 39 212



SYGEF® PLUS
Diaphragm valve type DIASTAR 025
Function DA (Double acting)
With butt fusion spigots IR metric

E

- With position indicator / Working pressure: both sides

d [mm]	DN [mm]	PN	kv-value ($\Delta p=1$ bar) [l/min]	PTFE/EPDM Code	kg
20	15	10	72	199 025 983	0.454
25	20	10	120	199 025 984	0.740
32	25	10	238	199 025 985	1.160
40	32	10	341	199 025 986	1.390
50	40	10	460	199 025 987	2.510
63	50	10	685	199 025 988	5.430

d [mm]	D [mm]	D1_G [inch]	D3[M] [mm]	L [mm]	L1 [mm]	L2 [mm]	H [mm]	H1 [mm]	H2 [mm]	H3 [mm]	H4 [mm]	H5 [mm]	H6 [mm]	H7 [mm]	H8 [mm]
20	68	1/8	6	124	60	25	98	59	24	23	44	100	155	44	76
25	96	1/8	6	144	60	25	127	71	25	23	44	100	155	56	88
32	96	1/8	6	154	60	25	141	85	25	23	44	100	155	56	88
40	120	1/8	8	174	60	45	167	97	26	36	64	100	160	68	100
50	150	1/4	8	194	60	45	198	108	36	36	64	100	170	85	117
63	150	1/4	8	224	60	45	216	126	36	36	64	100	170	85	117

d [mm]	H9 [mm]	H10 [mm]	Lift = Hx [mm]
20	14	12	8
25	18	12	10
32	21	12	12
40	26	15	14
50	33	15	18
63	39	15	22

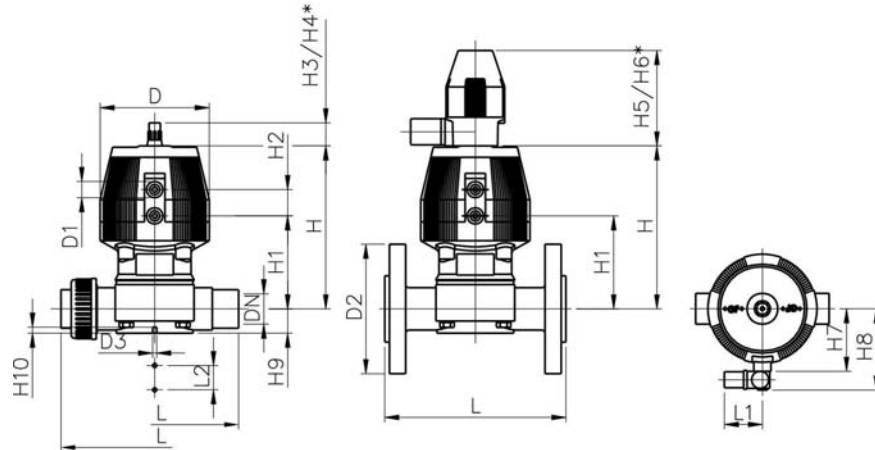

PF 3 39 212



SYGEF® PLUS

Diaphragm valve type DIASTAR 025

Function DA (Double acting)

Unions with fusion spigots metric

E

- With position indicator / Working pressure: both sides

d [mm]	DN [mm]	PN	kv-value ($\Delta p=1$ bar) [l/min]	PTFE/EPDM Code	kg
20	15	10	72	199 027 421	0.740
25	20	10	120	199 027 422	
32	25	10	238	199 027 423	
40	32	10	341	199 027 424	4.165
50	40	10	460	199 027 425	
63	50	10	685	199 027 426	

d [mm]	D [mm]	D1_G [inch]	D3[M] [mm]	L [mm]	L1 [mm]	L2 [mm]	H [mm]	H1 [mm]	H2 [mm]	H3 [mm]	H4 [mm]	H5 [mm]	H6 [mm]	H7 [mm]	H8 [mm]
20	68	1/8	6	225	60	25	98	59	24	23	44	100	155	44	76
25	96	1/8	6	242	60	25	127	71	25	23	44	100	155	56	88
32	96	1/8	6	254	60	25	141	85	25	23	44	100	155	56	88
40	120	1/8	8	308	60	45	167	97	26	36	64	100	160	68	100
50	150	1/4	8	330	60	45	198	108	36	36	64	100	170	85	117
63	150	1/4	8	373	60	45	216	126	36	36	64	100	170	85	117

d [mm]	H9 [mm]	H10 [mm]	Lift = Hx [mm]
20	14	12	8
25	18	12	10
32	21	12	12
40	26	15	14
50	33	15	18
63	39	15	22

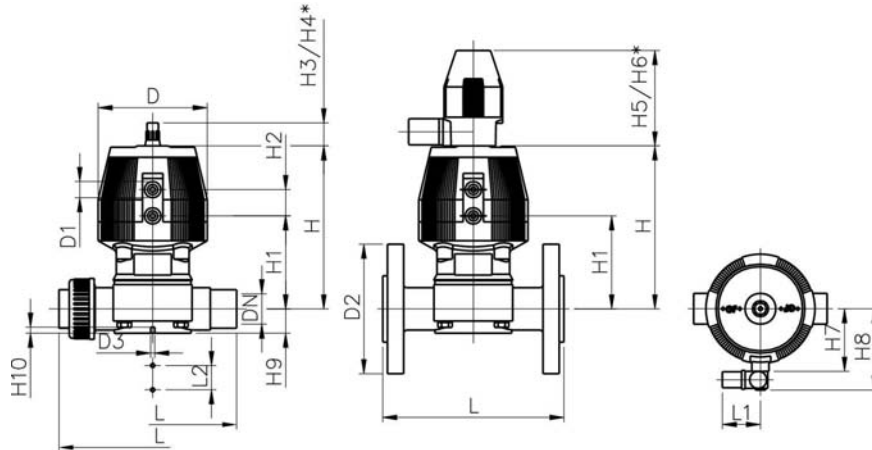

PF 3 39 212



SYGEF® PLUS
Diaphragm valve type DIASTAR 025
Function DA (Double acting)
With backing flanges PP-V metric

E

Model:

- Connecting dimensions: ISO 7005 / EN 1092 / DIN 2501 PN10 / BS4504
- With position indicator / Working pressure: both sides

d [mm]	DN [mm]	Inch	PN	kv-value ($\Delta p=1$ bar) [l/min]	PTFE/EPDM Code	kg
20	15	½	10	72	199 025 461	0.824
25	20	¾	10	120	199 025 462	1.090
32	25	1	10	238	199 025 463	1.610
40	32	1 ¼	10	341	199 025 464	1.950
50	40	1 ½	10	460	199 025 465	3.010
63	50	2	10	685	199 025 466	5.510

d [mm]	D [mm]	D1_G [inch]	D3[M] [mm]	D2 [mm]	L [mm]	L1 [mm]	L2 [mm]	H [mm]	H1 [mm]	H2 [mm]	H3 [mm]	H4 [mm]	H5 [mm]	H6 [mm]	H7 [mm]
20	68	¾	6	95	130	60	25	98	59	24	23	44	100	155	44
25	96	¾	6	105	150	60	25	127	71	25	23	44	100	155	56
32	96	¾	6	115	160	60	25	141	85	25	23	44	100	155	56
40	120	¾	8	140	180	60	45	167	97	26	36	64	100	160	68
50	150	¾	8	150	200	60	45	198	108	36	36	64	100	170	85
63	150	¾	8	165	230	60	45	216	126	36	36	64	100	170	85

d [mm]	H8 [mm]	H9 [mm]	H10 [mm]	Lift = Hx [mm]
20	76	14	12	8
25	88	18	12	10
32	88	21	12	12
40	100	26	15	14
50	117	33	15	18
63	117	39	15	22

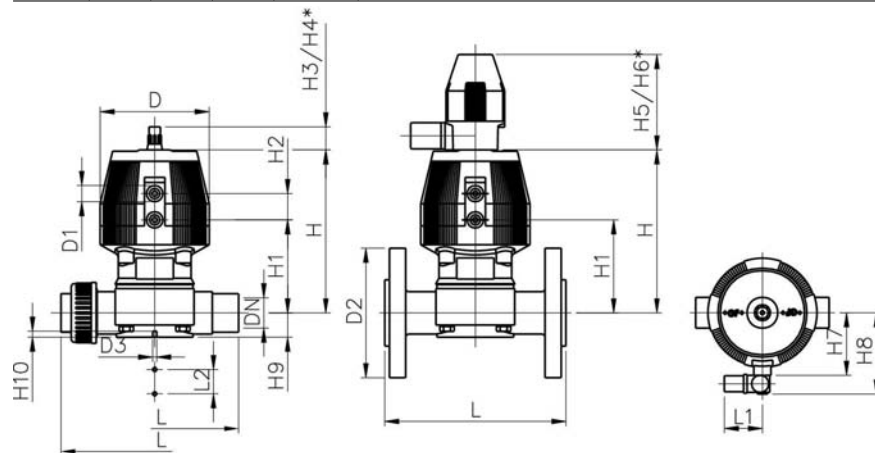

PF 3 39 212



SYGEF® PLUS

Diaphragm valve type DIASTAR 025

Function DA (Double acting)

With fixed flanges PVDF metric

E

Model:

- Connecting dimensions: ISO 7005 / EN 1092 / DIN 2501 PN10 / BS4504
- With position indicator / Working pressure: on one side

* With backing flanges PP-V

** Connecting dimensions DN80 and DN150 metric and Inch ANSI B16.5

d [mm]	DN [mm]	Inch	PN	kv-value ($\Delta p=1$ bar) [l/min]	PTFE/EPDM Code	kg
*75	65	2 ½	10	992	199 025 467	13.600
**90	80	3	10	1700	199 025 468	17.400
110	100	4	8	2700	199 025 469	24.700
**160	150	6	6	6033	199 025 470	35.000

d [mm]	D [mm]	D1_G [inch]	D2 [mm]	D3[M] [mm]	D4 [mm]	L [mm]	L2 [mm]	L3 [mm]	H [mm]	H1 [mm]	H2 [mm]	H3 [mm]
*75	280	¼	185	8	145	290	70		344	148	24	46
**90	280	¼	200	12	160	310	120		348	150	24	46
110	335	¼	225	12	180	350	120		395	176	24	46
**160	335	¼	285	12	240	480	100	200	455	237	24	46

d [mm]	H4 [mm]	H5 [mm]	H6 [mm]	H7 [mm]	H9 [mm]	H10 [mm]
*75	100	125	195	298	46	15
**90	100	129	195	302	57	15
110	100	129	195	349	69	20
**160	100	129	195	409	108	20

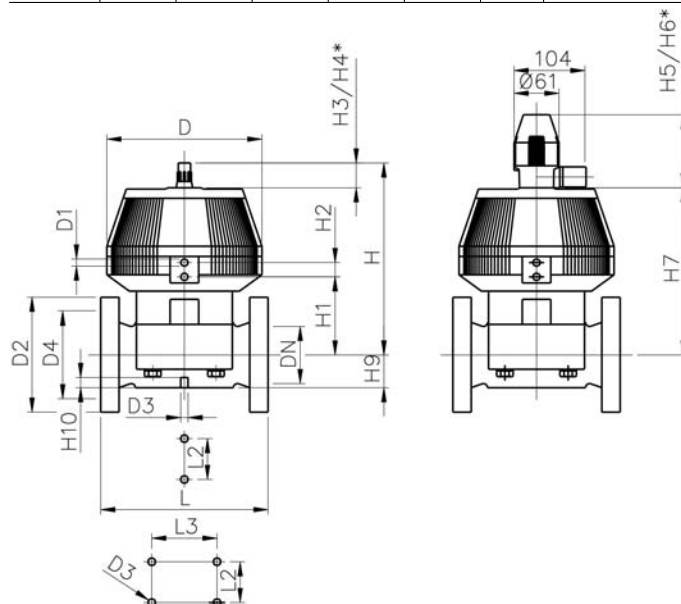

PF 3 39 212



SYGEF® PLUS

Diaphragm valve type DIASTAR 025

Function DA (Double acting)

With backing flanges PP-V ANSI

E

Model:

- Overall length according to EN 558-1
- Connecting dimension: ANSI B 16.5 class 150 (ASTM D 4024), BS EN 1759
- With position indicator / Working pressure: both sides

Inch	DN [mm]	PN	kv-value ($\Delta p=1$ bar) [l/min]	PTFE/EPDM Code
1/2	15	10	72	199 027 601
3/4	20	10	120	199 027 602
1	25	10	238	199 027 603
1 1/4	32	10	341	199 027 604
1 1/2	40	10	460	199 027 605
2	50	10	685	199 027 606

Inch	D [mm]	D1_G [inch]	D3[M] [mm]	D2 [mm]	L [mm]	L1 [mm]	L2 [mm]	H [mm]	H1 [mm]	H2 [mm]	H3 [mm]	H4 [mm]	H5 [mm]	H6 [mm]
1/2	68	1/8	6	95	130	60	25	98	59	24	23	44	100	155
3/4	96	1/8	6	105	150	60	25	127	71	25	23	44	100	155
1	96	1/8	6	115	160	60	25	141	85	25	23	44	100	155
1 1/4	120	1/8	8	140	180	60	45	167	97	26	36	64	100	160
1 1/2	150	1/4	8	150	200	60	45	198	108	36	36	64	100	170
2	150	1/4	8	165	230	60	45	216	126	36	36	64	100	170

Inch	H7 [mm]	H8 [mm]	H9 [mm]	H10 [mm]	Lift = Hx [mm]
1/2	44	76	14	12	8
3/4	56	88	18	12	10
1	56	88	21	12	12
1 1/4	68	100	26	15	14
1 1/2	85	117	33	15	18
2	85	117	39	15	22

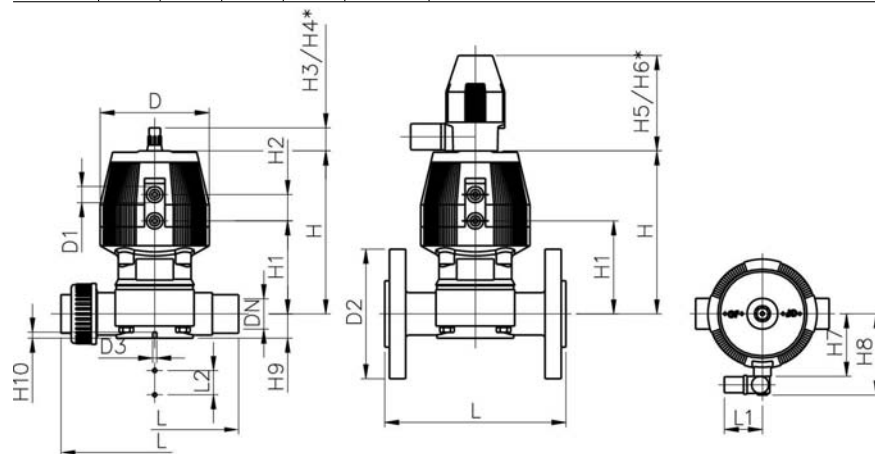

PF 3 39 212



SYGEF® PLUS

Diaphragm valve type DIASTAR 025

Function DA (Double acting)

With fixed flanges PVDF ANSI

E

Model:

- Overall length according to EN 558-1
- Connecting dimension: ANSI B 16.5 class 150 (ASTM D 4024), BS EN 1759
- With position indicator / Working pressure: on one side

* With backing flanges PP-V

** Connecting dimensions DN80 and DN150 metric and Inch ANSI B16.5

Inch	DN [mm]	PN	kv-value ($\Delta p=1$ bar) [l/min]	PTFE/EPDM Code	kg							
*2 1/2	65	10	992	199 025 407	13.600							
**3	80	10	1700	199 025 468	17.400							
4	100	8	2700	199 025 409	24.100							
**6	150	6	6033	199 025 470	35.000							

Inch	D [mm]	D1_G [inch]	D2 [mm]	D3[M] [mm]	D4 [mm]	L [mm]	L2 [mm]	L3 [mm]	H [mm]	H1 [mm]	H2 [mm]	H3 [mm]
*2 1/2	280	1/4	185	8	145	290	70		344	148	24	46
**3	280	1/4	200	12	160	310	120		348	150	24	46
4	335	1/4	225	12	180	350	120		395	176	24	46
**6	335	1/4	285	12	240	480	100	200	455	237	24	46

Inch	H4 [mm]	H5 [mm]	H6 [mm]	H7 [mm]	H9 [mm]	H10 [mm]
*2 1/2	100	125	195	298	46	15
**3	100	129	195	302	57	15
4	100	129	195	349	69	20
**6	100	129	195	409	108	20

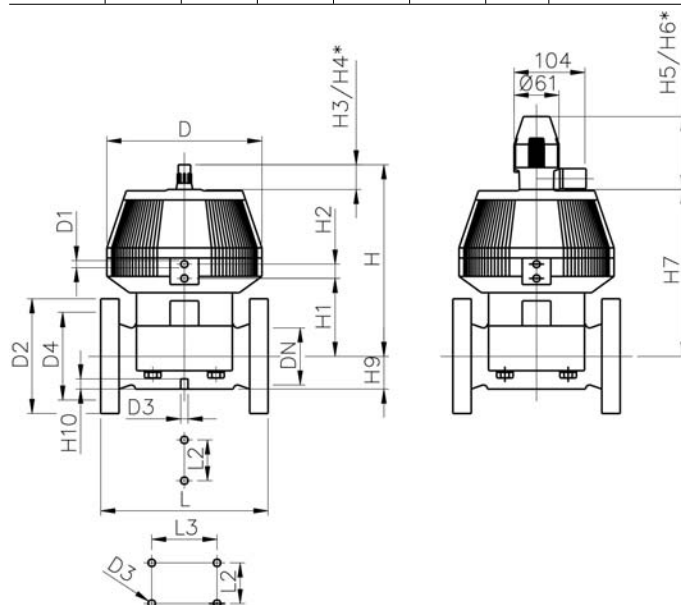

PF 3 39 212



SYGEF® PLUS
Diaphragm valve type DIASTAR 025
Function DA (Double acting)
ZERO STATIC with butt fusion spigots metric

E

- DN2: for coordination of accessoires

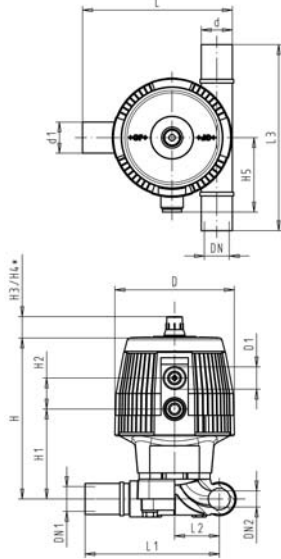

d	d1	DN	DN1	DN2	PN	kv-value ($\Delta p=1$ bar) [l/min]	PTFE/EPDM Code	kg
20	20	15	15	15	10	47	199 028 067	
25	20	20	15	20	10	69	199 028 068	
25	25	20	20	20	10	91	199 028 069	
32	20	25	15	25	10	86	199 028 070	
32	25	25	20	25	10	126	199 028 077	
32	32	25	25	25	10	156	199 028 078	4.900
40	20	32	15	25	10	84	199 028 079	
40	25	32	20	25	10	124	199 028 177	
40	32	32	25	25	10	161	199 028 178	
40	40	32	32	32	10	250	199 028 179	0.900
50	20	40	15	25	10	82	199 028 080	
50	25	40	20	25	10	124	199 028 087	
50	32	40	25	25	10	159	199 028 088	
50	40	40	32	40	10	312	199 028 157	3.350
50	50	40	40	40	10	356	199 028 158	
63	20	50	15	25	10	81	199 028 089	
63	25	50	20	25	10	115	199 028 090	4.900
63	32	50	25	25	10	156	199 028 097	
63	40	50	32	50	10	383	199 028 138	4.900
63	50	50	40	50	10	487	199 028 137	
63	63	50	50	50	10	544	199 028 139	
75	40	65	32	32	10	256	199 028 098	
75	50	65	40	50	10	497	199 028 159	
75	63	65	50	50	10	546	199 028 160	
90	20	80	15	25	10	88	199 028 099	
90	25	80	20	25	10	133	199 028 100	
90	32	80	25	25	10	162	199 028 107	
90	50	80	40	50	10	504	199 028 108	
90	63	80	50	50	10	530	199 028 109	
110	20	100	15	25	10	89	199 028 110	
110	25	100	20	25	10	123	199 028 117	
110	32	100	25	25	10	159	199 028 118	
110	50	100	40	50	10	503	199 028 119	
110	63	100	50	50	10	543	199 028 120	

d	L	L1	L2	L3	H	H1	H2	H3	H4	H5	D	D1	Lift = Hx
[mm]	[mm]	[mm]	[mm]	[mm]	[mm]	[mm]	[mm]	[mm]	[mm]	[mm]	[mm]	[inch]	[mm]
20	106	96	30	140	99	59	24	23	44	44	68	1/8	8
25	121	108	36	150	130	71	25	23	44	56	96	1/8	10
25	121	108	36	150	130	71	25	23	44	56	96	1/8	10
32	137	120	43	160	143	85	25	23	44	56	96	1/8	12
32	137	120	43	160	143	85	25	23	44	56	96	1/8	12
32	137	120	43	160	143	85	25	23	44	56	96	1/8	12
40	149	128	51	180	143	85	25	23	44	56	96	1/8	12
40	149	128	51	180	143	85	25	23	44	56	96	1/8	12
40	149	128	51	180	143	85	25	23	44	56	96	1/8	12
40	174	153	56	190	170	97	26	36	64	68	120	1/8	14
50	159	134	57	180	143	85	25	23	44	56	96	1/8	12
50	159	134	57	180	143	85	25	23	44	56	96	1/8	12
50	159	134	57	180	143	85	25	23	44	56	96	1/8	12
50	195	169	66	200	203	108	36	36	64	85	150	1/4	18
50	195	169	66	200	203	108	36	36	64	85	150	1/4	18
63	175	144	67	180	143	85	25	23	44	56	96	1/8	12
63	175	144	67	180	143	85	25	23	44	56	96	1/8	12
63	175	144	67	180	143	85	25	23	44	56	96	1/8	12
63	223	192	80	220	220	126	36	36	64	85	150	1/4	22
63	225	192	80	220	220	126	36	36	64	85	150	1/4	22

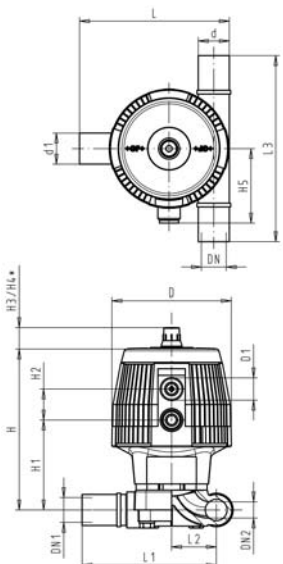

d [mm]	L [mm]	L1 [mm]	L2 [mm]	L3 [mm]	H [mm]	H1 [mm]	H2 [mm]	H3 [mm]	H4 [mm]	H5 [mm]	D [mm]	D1 [inch]	Lift = Hx [mm]
63	223	192	80	220	220	126	36	36	64	85	150	1/4	22
75	203	166	78	190	170	97	26	36	64	68	120	1/8	14
75	236	198	86	220	220	126	36	36	64	85	150	1/4	22
75	236	198	86	220	220	126	36	36	64	85	150	1/4	22
90	204	159	82	160	143	85	25	23	44	56	96	1/8	12
90	204	159	82	160	143	85	25	23	44	56	96	1/8	12
90	204	159	82	160	143	85	25	23	44	56	96	1/8	12
90	252	207	95	220	220	126	36	36	64	85	150	1/4	22
90	252	207	95	220	220	126	36	36	64	85	150	1/4	22
110	226	171	94	160	143	85	25	23	44	56	96	1/8	12
110	226	171	94	160	143	85	25	23	44	56	96	1/8	12
110	226	171	94	160	143	85	25	23	44	56	96	1/8	12
110	274	219	107	220	220	126	36	36	64	85	150	1/4	22
110	274	219	107	220	220	126	36	36	64	85	150	1/4	22

PF 3 39 212



SYGEF® PLUS
Diaphragm valve type DIASTAR 025
Function DA (Double acting)
With butt fusion spigots IR metric HTR

- With position indicator / Working pressure: both sides for correct clamping and fusion jointing of flange adapters

d [mm]	DN [mm]	PN	kv-value ($\Delta p=1$ bar) [l/min]	PTFE/EPDM Code
20	15	10	72	199 027 751
25	20	10	120	199 027 752
32	25	10	238	199 027 753
40	32	10	341	199 027 754
50	40	10	460	199 027 755
63	50	10	685	199 027 756

d [mm]	D [mm]	D1_G [inch]	D3[M] [mm]	L [mm]	L1 [mm]	L2 [mm]	H [mm]	H1 [mm]	H2 [mm]	H3 [mm]	H4 [mm]	H5 [mm]	H6 [mm]	H7 [mm]	H8 [mm]
20	68	1/8	6	124	60	25	98	59	24	23	44	100	155	44	76
25	96	1/8	6	144	60	25	127	71	25	23	44	100	155	56	88
32	96	1/8	6	154	60	25	141	85	25	23	44	100	155	56	88
40	120	1/8	8	174	60	45	167	97	26	36	64	100	160	68	100
50	150	1/4	8	194	60	45	198	108	36	36	64	100	170	85	117
63	150	1/4	8	224	60	45	216	126	36	36	64	100	170	85	117

d [mm]	H9 [mm]	H10 [mm]	Lift = Hx [mm]
20	14	12	8
25	18	12	10
32	21	12	12
40	26	15	14
50	33	15	18
63	39	15	22

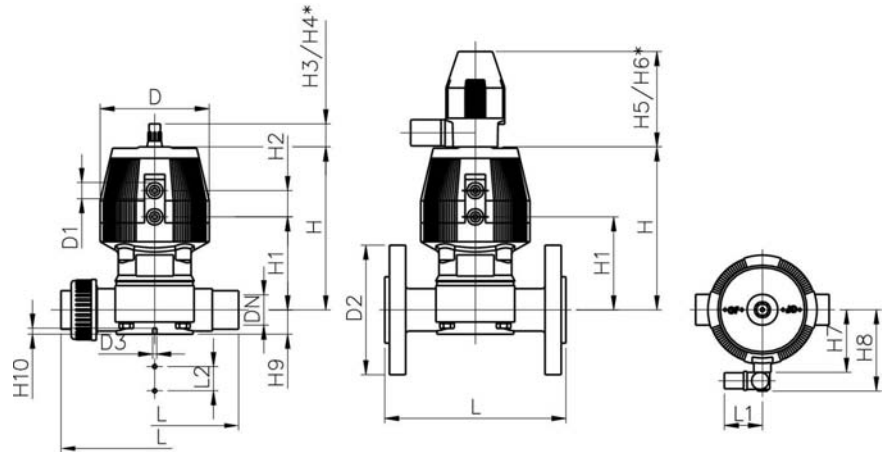



SYGEF® PLUS

Diaphragm valve type DIASTAR 025

Function DA (Double acting)

Unions with fusion spigots metric HTR

- With position indicator / Working pressure: both sides for correct clamping and fusion jointing of flange adapters

d [mm]	DN [mm]	PN	kv-value ($\Delta p=1$ bar) [l/min]	PTFE/EPDM Code
20	15	10	72	199 027 791
25	20	10	120	199 027 792
32	25	10	238	199 027 793
40	32	10	341	199 027 794
50	40	10	460	199 027 795
63	50	10	685	199 027 796

d [mm]	D [mm]	D1_G [inch]	D3[M] [mm]	L [mm]	L1 [mm]	L2 [mm]	H [mm]	H1 [mm]	H2 [mm]	H3 [mm]	H4 [mm]	H5 [mm]	H6 [mm]	H7 [mm]	H8 [mm]
20	68	1/8	6	225	60	25	98	59	24	23	44	100	155	44	76
25	96	1/8	6	242	60	25	127	71	25	23	44	100	155	56	88
32	96	1/8	6	254	60	25	141	85	25	23	44	100	155	56	88
40	120	1/8	8	308	60	45	167	97	26	36	64	100	160	68	100
50	150	1/4	8	330	60	45	198	108	36	36	64	100	170	85	117
63	150	1/4	8	373	60	45	216	126	36	36	64	100	170	85	117

d [mm]	H9 [mm]	H10 [mm]	Lift = Hx [mm]
20	14	12	8
25	18	12	10
32	21	12	12
40	26	15	14
50	33	15	18
63	39	15	22

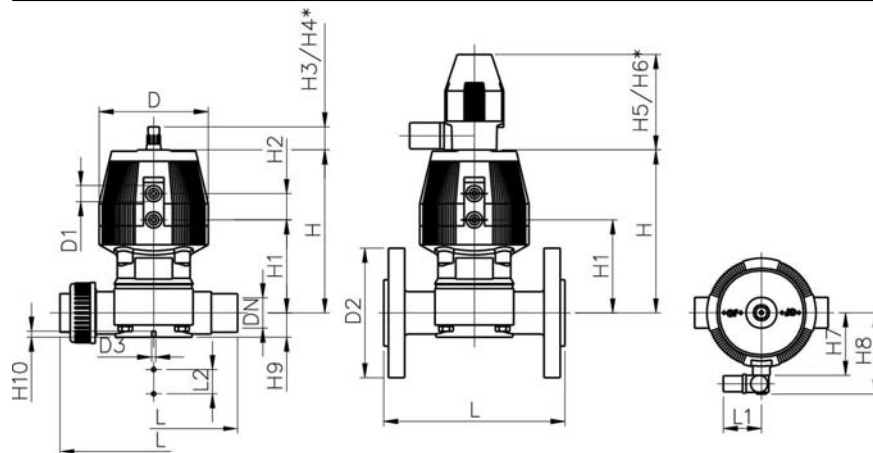

SYGEF® Plus

Butterfly Valve Type 365 Lug-Style - Bareshaft



Model:

- Metal lugged body with epoxy-coating
- PFA coated disc with PTFE liner
- HP produced & double-bagged
- Bareshaft to ISO5211
- Lugged body to ANSI B16.5 #150 or ISO/EN 1092 PN16

d (mm)	DN (mm)	Inch	PN	Kv value L/min (ΔP=1BAR)	Lugged ANSI B16.5 #150 Code	Lugged ISO/EN 1092 Code	KG	Torque Nm	ISO5211 (square shaft)
63	50	2	16	3199	160 365 423	160 365 551	4.7	30	F07/11mm
75	65	2½	16	3199	160 365 424	160 365 552	6	30	F07/11mm
90	80	3	16	6497	160 365 425	160 365 553	6.5	40	F07/11mm
110	100	4	16	9696	160 365 426	160 365 554	8.5	50	F07/14mm
140	125	5	16	16808	160 365 427	160 365 555	10.6	60	F07/14mm
160	150	6	16	24762	160 365 428	160 365 556	13.9	110	F07/17mm
225	200	8	10	50523	160 365 429	160 365 557	17.9	180	F10/17mm
280	250	10	10	74713	160 365 430	160 365 558	27.2	250	F10/22mm
315	300	12	10	119438	160 365 431	160 365 559	35.9	350	F10/22mm

Pneumatic Actuator for Type 365



Model:

- Hard-anodized aluminium body
- NAMUR connection for mounting accessories

d	DN	Inch	FC/FO Code	DA Code	Type
63-75	50-65	2-2½	198 800 037	198 800 758	PA 35
90	80	3	198 800 728	198 800 759	PA 40
110	100	4	198 800 039	198 800 040	PA 45
140	125	5	198 800 729	198 800 733	PA 50
160	150	6	198 800 041	198 800 042	PA 55
225	200	8	198 800 730	198 800 734	PA 60
280	250	10	198 800 043	198 800 044	PA 65
315	300	12	198 800 731	198 800 735	PA 70

Assembly kit for Type 365 with Pneumatic Actuator Without Manual Override



Model:

- Includes all necessary parts to mount actuator to bareshaft valve

d	DN	Inch	FC/FO Code	DA Code
63-75	50-65	2-2½	198 000 383	198 000 383
90	80	3	198 000 385	198 000 384
110	100	4	198 000 386	198 000 386
140	125	5	198 000 386	198 000 386
160	150	6	198 000 389	198 000 389
225	200	8	198 000 389	198 000 389
280	250	10	on request	198 000 392
315	300	12	on request	198 000 393

- Order bareshaft valve, actuator and assembly kit as separate items
- Electric Actuation available on request

Process control valves

SYGEF® PLUS

Pressure reducing valve type V 782 With fusion spigots BCF

E

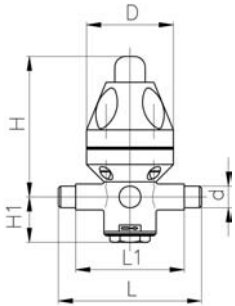

PF 3 58 458

d [mm]	DN [mm]	Pressure range [bar]	PTFE Code	kg	D [mm]	L [mm]	L1 [mm]	H [mm]	H1 [mm]
20	15	0.5 - 10	199 041 192	1.300	83	182	102	195	48
25	20	0.5 - 10	199 041 193	1.300	112	190	110	210	65
32	25	0.5 - 10	199 041 194	1.300	112	190	110	210	65
40	32	0.5 - 10	199 041 195	4.840	165	262	162	260	95
50	40	0.5 - 10	199 041 196	4.840	165	262	162	260	95

SYGEF® PLUS

Pressure reducing valve type V 82 With fusion spigots BCF

E

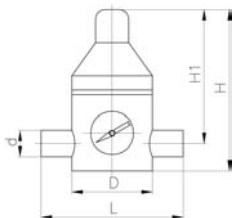

PF 3 58 458

d [mm]	DN [mm]	Pressure range [bar]	PTFE Code	kg	D [mm]	L [mm]	H [mm]	H1 [mm]
20	15	0.5 - 10	199 041 184	0.790	70	150	130	100
25	20	0.5 - 10	199 041 185	1.619	100	190	180	134
32	25	0.5 - 10	199 041 186	1.620	100	190	180	134
40	32	0.5 - 10	199 041 187	5.320	130	240	230	175
50	40	0.5 - 10	199 041 188	5.320	130	240	230	175
63	50	0.5 - 10	199 041 189	9.330	150	260	285	210

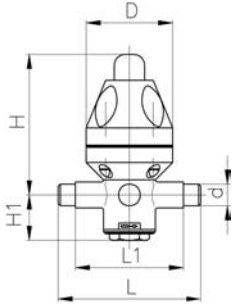

PF 3 58 458

SYGEF® PLUS Pressure retaining valve type V 786 With fusion spigots BCF

E

d [mm]	DN [mm]	Pressure range [bar]	PTFE Code	kg	D [mm]	L [mm]	L1 [mm]	H [mm]	H1 [mm]
20	15	0.5 - 10	199 041 198	0.620	83	172	102	145	38
25	20	0.5 - 10	199 041 199	1.700	112	190	110	210	55
32	25	0.5 - 10	199 041 200	1.700	112	190	110	210	55
40	32	0.5 - 4	199 041 201	4.840	165	262	162	260	85
50	40	0.5 - 4	199 041 202	4.840	165	262	162	260	85

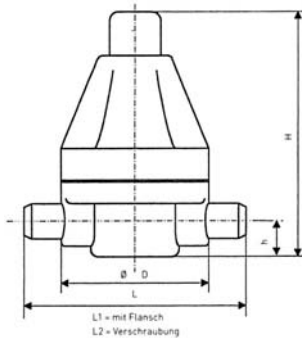

PF 3 58 458

SYGEF® PLUS Pressure retaining valve type V 186 With butt fusion spigots BCF IR

E

d [mm]	DN [mm]	Pressure range [bar]	PTFE Code	kg	D [mm]	L [mm]	H [mm]	H1 [mm]
20	15	0.5 - 10	199 041 395	0.600	83	158	137	20
25	20	0.5 - 10	199 041 396	0.600	83	158	137	20
32	25	0.5 - 10	199 041 397	1.600	112	198	199	27
40	32	0.5 - 10	199 041 398	1.600	112	202	199	43
50	40	0.5 - 10	199 041 399	8.000	165	256	290	43
63	50	0.5 - 10	199 041 400	8.200	165	256	290	43



SYGEF® standard
Pressure retaining valve type V 86
With fusion spigots metric

E

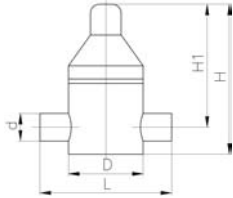

PF 3 58 458

d [mm]	DN [mm]	Pressure range [bar]	PTFE Code	kg	D [mm]	L [mm]	H [mm]	H1 [mm]	
75	65	1.0 - 6	199 041 892	7.730	180	284	275	230	



SYGEF® PLUS
Pressure relief valve type V 185
With butt fusion spigots metric IR

E

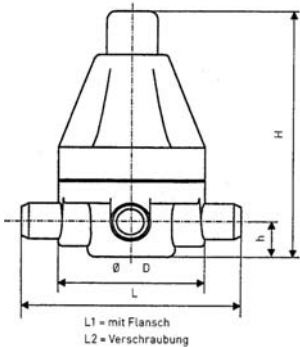

PF 3 58 458

d [mm]	DN [mm]	Pressure range [bar]	PTFE Code	kg	D [mm]	L [mm]	H [mm]	H1 [mm]	
20	15	0.5 - 10	199 041 520	0.700	83	158	137	20	
25	20	0.5 - 10	199 041 521	0.700	83	158	137	20	
32	25	0.5 - 10	199 041 522	1.700	112	198	199	27	
40	32	0.5 - 10	199 041 523	1.700	165	202	199	43	
50	40	0.5 - 10	199 041 524	8.100	165	256	290	43	
63	50	0.5 - 10	199 041 525	8.300	165	256	290	43	



SYGEF® standard
Pressure relief valve type V 85
With fusion spigots metric

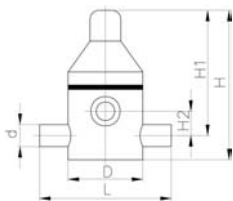

PF 3 58 458

d [mm]	DN [mm]	Pressure range [bar]	PTFE Code	kg	D [mm]	L [mm]	H [mm]	H1 [mm]	H2 [mm]	
75	65	1.0 - 6	199 041 898	13.000	180	284	295	250	70	

Variable area flow meters

**Special version PVDF-HP
Float in PTFE
With fusion spigot BCF**

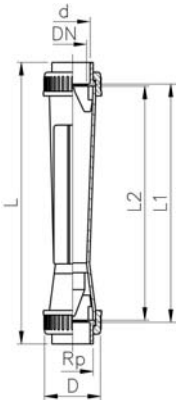

PF 3 48 227

Type	d [mm]	DN [mm]	Scale range [l/h]	Scale range [gal/min]	Taper tube in Polysulfone O-rings in FPM Code	kg
SK 73	32	25	136 - 795	0.6-3.5	198 801 202	0.300
SK 20	50	40	568 - 2273	2.5-10.0	198 801 203	1.150
SK 21	50	40	909 - 4091	4.0-18.0	198 801 204	1.150
SK 30	63	50	1000 - 8142	4.4-36.0	198 801 205	1.500
SK 31	63	50	1000 - 9091	4.4-40.0	198 801 206	1.500
SK 40	75	65	1848 - 11364	8.0-50.0	198 801 207	2.500
SK 41	75	65	2273 - 16364	10.0-72.0	198 801 208	2.500

Type	D [mm]	L [mm]	L1 [mm]	L2 [mm]	Rp [inch]
SK 73	60	338		200	1
SK 20	83	511		335	1 ½
SK 21	83	511		335	1 ½
SK 30	103	524		335	2
SK 31	103	524		335	2
SK 40	122	495		335	2 ½
SK 41	122	495		335	2 ½

SYGEF® Exhaust

	Page
 Pipe	285
Fittings	286
Flanges and Gaskets	288

SYGEF® Exhaust – Product Specification

Material	Polyvinylidene fluoride (PVDF)
Colour	translucent
Density	~1.78g/cm ³ (ISO 1183 / ASTM D 792)
Surface tension	30–35mJ/m ²
Linear expansion coefficient	0.12–0.18mm/mK (DIN 53752)
E-module (tensile strength)	2100N/mm ² (ISO 527/ASTM D 790)
Thermal conductivity	0.19W/mK (DIN 52612)
Surface resistivity	5x 10 ¹⁴ Ωcm (IEC 60093)
Dimension	d 75 (2½")–d 400 (16")
Pressure Rating	Maximum negative pressure: -ΔPmax = 1500Pa (0.015 bar, 6" water column)
Temperature Rating	PVDF: -20°C to 140°C [-4°F-284°F], System: ΔT= 30°C
Production	Fittings: injection moulded, segment welded Pipes: extruded
Marking	All components are embossed with a permanent identification during the production process to ensure full traceability. Lot No Material Dimension
Testing and Inspection	Inclusions Visual inspection Dimension tolerance
Approvals/Conformance	FM-4910 listing: www.fmglobal.com
Welding Technology	Hot Gas Back Welding, Rod diameter 4 mm Recommended tool: duratherm SC Recommended Manufacturer: www.wegenerwelding.com
Documentation⁽¹⁾	EN 10204 2.2 EN 10204 3.1b
Packing	Fitting: multiple components bagged in specified bag Pipe: capped and single bagged in specified bag
Labeling	Brand Name Product Description Code Number Material Dimension CE-Labeling
Main Applications	Safe conveying of critical exhaust gases and fumes within state-of-the-art manufacturing plants. Due to its excellent chemical resistance it is widely used within the Microelectronics and Chemical Industry.

⁽¹⁾ on request

Pipe

Pipe, PVDF (Exhaust)

H

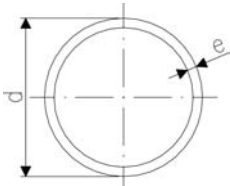

PF 2 35 784

d [mm]	Code	e [mm]	Weight [kg/m]	Length [m]	
75	175 483 459	3.0	1.310	5.00	
110	175 483 461	3.0	1.940	5.00	
160	175 483 464	3.0	2.850	5.00	
200	175 483 466	3.0	3.580	5.00	
250	175 483 468	3.0	4.480	5.00	
315	175 483 470	4.0	7.470	5.00	
400	175 483 472	5.0	11.800	5.00	

Fittings

Bend 90°, PVDF (Exhaust)

K

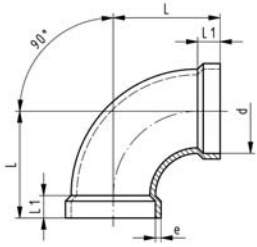

Model:

- for conventional hot gas back welding according to DVS 2207 part 3

d [mm]	Code	kg	e [mm]	L [mm]	L1 [mm]
75	735 550 112	0.220	3.0	115	40
110	735 550 114	0.520	3.0	150	40
160	735 550 117	1.060	3.0	200	40
200	735 550 119	1.600	3.0	240	40
250	735 550 121	3.030	3.5	290	40
315	735 550 123	4.000	4.0	365	50
400	735 550 125	7.400	4.5	450	50

PF 2 35 784

Bend 45°, PVDF (Exhaust)

K

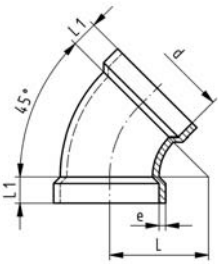

Model:

- for conventional hot gas back welding according to DVS 2207 part 3

d [mm]	Code	kg	e [mm]	L [mm]	L1 [mm]
75	735 550 212	0.200	3.0	75	40
110	735 550 214	0.370	3.0	110	40
160	735 550 217	0.700	3.0	160	40
200	735 550 219	1.000	3.0	200	40
250	735 550 221	1.770	3.5	250	40
315	735 550 223	2.520	4.0	315	50
400	735 550 225	4.520	4.5	400	50

PF 2 35 784

T 90° equal, PVDF (Exhaust)

K

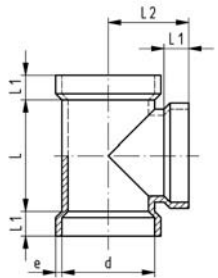

Model:

- for conventional hot gas back welding according to DVS 2207 part 3

d [mm]	Code	kg	e [mm]	L [mm]	L1 [mm]	L2 [mm]
75	735 550 312	0.320	3.0	105	40	92.5
110	735 550 314	0.520	3.0	140	40	110.0
160	735 550 317	0.880	3.0	190	40	135.0
200	735 550 319	1.300	3.0	230	40	155.0
250	735 550 321	2.310	3.0	290	40	180.0
315	735 550 323	4.370	4.0	370	50	222.5
400	735 550 325	7.600	5.0	440	50	265.0

PF 2 35 784

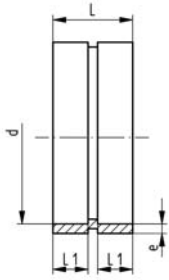

Socket equal, PVDF (Exhaust)

K

Model:

- for conventional hot gas back welding according to DVS 2207 part 3

d [mm]	Code	kg	e [mm]	L [mm]	L1 [mm]
75	735 550 512	0.180	3.0	120	40
110	735 550 514	0.230	3.0	110	40
160	735 550 517	0.340	3.0	110	40
200	735 550 519	0.450	3.0	110	40
250	735 550 521	0.660	3.5	110	40
315	735 550 523	1.120	4.0	140	50
400	735 550 525	1.630	4.5	140	50

PF 2 35 784

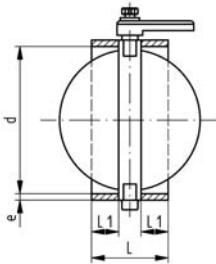

Damper, PVDF (Exhaust)

K

Model:

- for conventional hot gas back welding according to DVS 2207 part 3

d [mm]	Code	kg	e [mm]	L [mm]	L1 [mm]
75	735 550 412	0.400	3.0	160	40
110	735 550 414	0.510	3.0	150	40
160	735 550 417	0.760	3.0	150	40
200	735 550 419	0.990	3.5	150	40
250	735 550 421	1.420	3.5	150	40
315	735 550 423	2.270	4.0	180	50
400	735 550 425	3.280	4.5	180	50

PF 2 35 784

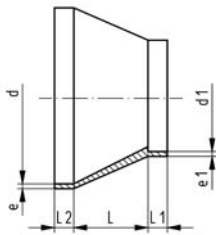

Reducer, PVDF (Exhaust)

K

Model:

- for conventional hot gas back welding according to DVS 2207 part 3

d - d1 [mm]	Code	kg	L [mm]	L1 [mm]	L2 [mm]
110 - 75	735 550 814	0.280	80	40	40
160 - 110	735 550 817	0.600	140	40	40
200 - 160	735 550 819	0.760	120	40	40
250 - 200	735 550 821	1.140	140	40	40
315 - 250	735 550 823	1.570	100	40	50
400 - 315	735 550 825	2.350	120	50	50

PF 2 35 784

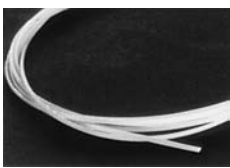

Welding Rod

Model:

- Colour: natural or coloured
- Extruded
- Minimum quantity to be ordered : 1kg

Dimension [mm]	Cross-section	Length	Code	Weight
3	O	1 m	175 480 323	1 kg = 80 m
3	O	coiled	175 480 318	1 kg = 80 m
3x5	O	1 m	175 480 322	1 kg = 50 m
4	O	1 m	175 480 324	1 kg = 45 m
4	O	coiled	175 480 319	1 kg = 45 m
3	O Color	coiled	175 480 320	1 kg = 80 m
4	O Color	coiled	175 480 321	1 kg = 45 m

PF 2 35 186

Flanges and Gaskets

Fix Flange, PVDF (Exhaust)

K

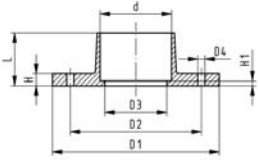

Model:

- for conventional hot gas back welding according to DVS 2207 part 3

d [mm]	Code	kg	L [mm]	D1 [mm]	D2 [mm]	D3 [mm]	D4 [mm]	AL [mm]	H [mm]	H1 [mm]
75	735 550 612	0.160	29	140	110	69	10	8	8	3
110	735 550 614	0.200	30	170	150	104	10	8	8	3
160	735 550 617	0.310	30	230	200	154	10	8	8	3
200	735 550 619	0.380	30	270	240	194	10	8	8	3
250	735 550 621	0.440	30	320	290	244	10	12	8	3
315	735 550 623	0.780	30	395	350	307	10	12	12	3
400	735 550 625	0.940	30	475	445	390	10	16	12	3

PF 2 35 784

FPM Gasket (Exhaust)

K

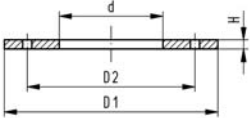

d [mm]	Code	kg	D1 [mm]	D2 [mm]
75	749 400 112	0.060	140	110
110	749 400 114	0.080	170	150
160	749 400 117	0.130	230	200
200	749 400 119	0.160	270	240
250	749 400 121	0.180	320	290
315	749 400 123	0.210	395	350
400	749 400 125	0.310	445	475

PF 2 35 784

Blind Flange, PVDF (Exhaust)

K

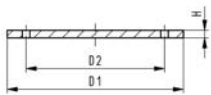

Model:

- for conventional hot gas back welding according to DVS 2207 part 3

d [mm]	Code	kg	D1 [mm]	D2 [mm]	AL [mm]	H [mm]
75	735 550 712	0.220	140	110	8	8
110	735 550 714	0.320	170	150	8	8
160	735 550 717	0.590	230	200	8	8
200	735 550 719	0.810	270	240	8	8
250	735 550 721	1.120	320	290	12	8
315	735 550 723	1.720	395	350	12	10
400	735 550 725	2.470	475	445	16	10

PF 2 35 784

SYGEF-PFA

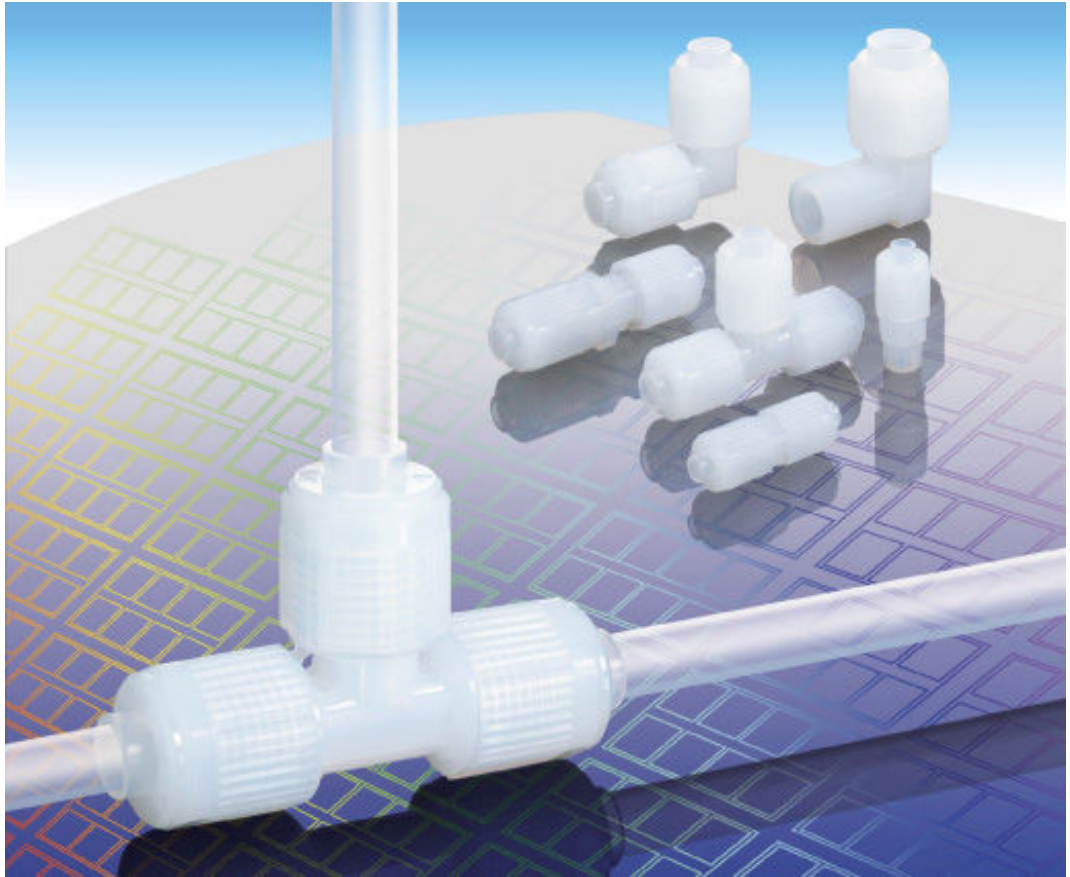

In partnership with SMC Corporation of Japan, GF Piping Systems introduces the SYGEF-PFA range of tubes, fittings and valves in High-Purity PFA material in the sizes 1/8" to 1 1/4".

- LVQ Valves
- LQ3 Flare-Type Fitting
- TL/TIL Tubing
- SRF/LVR Pressure Regulators
- PAF Diaphragm Pumps

SYGEF-PFA is ideally suited to the distribution of ultra-pure and highly corrosive fluids in various applications throughout Semiconductor and Microelectronics manufacturing, as well as Chemical Process Industries.

Please consult our separate product range document for further information on SYGEF-PFA.

FUSEAL 25/50



GF Piping Systems Fuseal 25/50 corrosive waste piping system is produced from Kynar PVDF to provide excellent chemical resistance and flame/smoke retardance. Fuseal 25/50 is a dedicated drainage piping system, with fittings in drainage pattern design.

Jointing is by electrofusion fittings (with MSA250-EX electrofusion control unit) or by mechanical joints and union connections. Fuseal 25/50 is also available in a double-containment system on request.

Fuseal is also available in PP and PP-FR (Flame Retardant) materials.

Please consult our separate product range document for further information on FUSEAL 25/50.

Semifinished Products

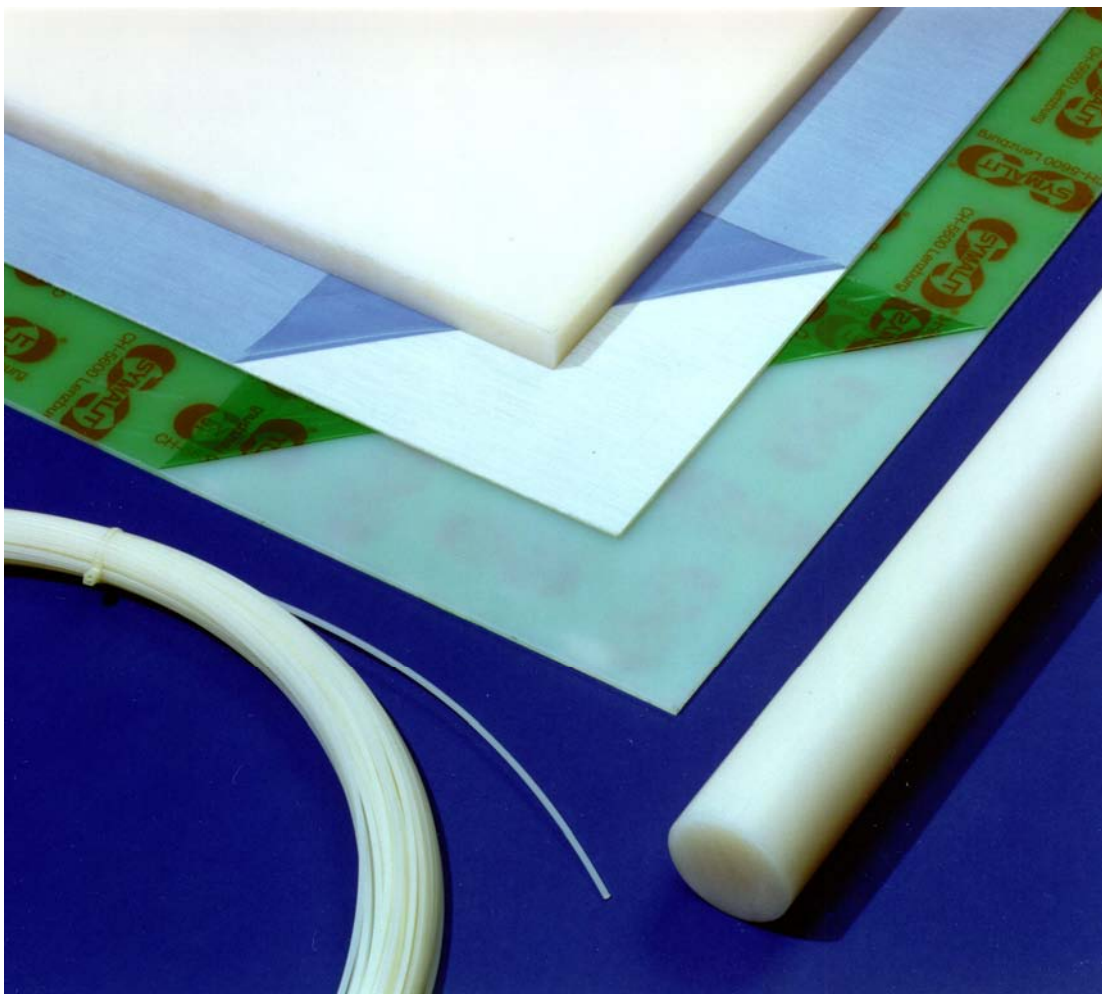

- Stock Shapes of Bars, Rods and Blocks
- Sheets, Rolls and Lining Laminates
- Welding Rod and Cap Strips
- Special Pipes and Liner Pipes









In addition to our range of piping systems and jointing technologies, GF Piping Systems offers a range of Semifinished Products in Fluoropolymer materials:

- | | | |
|--------------------|---------|--------|
| - PVDF Standard | - ECTFE | - FEP |
| - PVDF High-Purity | - ETFE | - MFA |
| - PVDF Flex | - PFA | - PTFE |

Other materials such as PVC-U, PVC-C, ABS, PP & PE100 also available.

Please consult our separate product range document for further information on Semifinished Products.

System-Oriented Fusion Jointing Machines

		Page
	IR-63 Plus® and IR-225 Plus® Fusion Jointing Machines	295
	IR-315 Plus® Fusion Jointing Machine	297
	Accessories for the IR plastic fusion jointing machines	298
	BCF® Plus Plastic Fusion Jointing Machine	302
	SG 110 Socket fusion machine	305
	SG 110 Accessories	306
	SG 110 Special accessories	307
	Preparation Tools & Accessories	308

IR-Plus® Product Specifications

Fusion Technology	<p>Non-contact radiant heating Joining pressure produced by overlap distance Software controlled, reproducible and monitored fusion and cooling process Cooling process determined by fusion zone temperature via infrared sensor (IR225/315-Plus) Remote fusion unit (IR63-Plus) Pre-programmed and key-protected fusion parameters Fusion protocol storage of 1800 fusions with unique fusion numbers Fusion factor ≥ 0.93 Fusion + cooling time typically between 35% and 57% of conventional butt-fusion (DVS 2207-15) User guidance in 8 languages Integrated error recognition Automated maintenance intervals World-wide welder installation training and certification programme World-wide weld-bead inspection training and certification programme</p>	
Piping Material	<p>SYGEF® Plus (PVDF HP) SYGEF® Standard (PVDF Standard) PROGEF® Plus (PP-H CDB) PROGEF® Natural (PP Natural) DEKAPROP / Beta PP (β-PP-H) PE100 / HDPE PFA Sch40 (on request only)</p>	
Dimension	IR63-Plus	d20 (1/2") – d63 (2")
	IR225-Plus	d63 (2") – d225 (9")
	IR315-Plus	d250 (10") – d315 (12")
Pre-fusion treatment	<p>Cleaning with Tangit KS and lint-free tissue (KO-TON-R) Facing by integrated facing tool Airflow around fusion machine maximum 0.2 m/s</p>	
Weld bead	<p>Typically 50% smaller than conventional butt-fusion (DVS 2207-15)</p>	
Post-fusion treatment	<p>Software controlled cooling phase No additional treatment after cooling phase complete</p>	
Fusion Documentation	<p>Print-out of 2 identical labels for labelling of piping system and/or isometric drawing</p> <ul style="list-style-type: none"> • Date • 2 Joint numbers (1 fixed, 1 user selectable) • Machine number • Process status symbol (OK / NOK) • Welder / supervisor visa <p>Print-out of fusion protocol via A4 printer</p> <ul style="list-style-type: none"> • Date • Time • Machine number • 2 Joint numbers (1 fixed, 1 user selectable) • Operator • Worksite • Process status (OK / NOK) • Chosen parameter (material, size, series, PN, wall thickness) • Process parameters (overlap and facing distance, temperatures, times) • Confirmation and signature <p>Electronic record downloadable, write protected stored and administered via WIN WELD software package for PC/MAC</p>	
Testing and Inspection	<p>Sample fusions one per job site and dimension Weld-bead inspection as per GF control document Weld-bead inspection as per DVS control document</p>	
Conformances/Standards	<p>DVS 2207-6 (2003) SEMI F57</p>	
Main applications	<p>Alternative to conventional butt-fusion in applications where purity, weld-strength, traceability and speed of installation are imperative. Typical market segments include Semiconductor/Microelectronics, Chemical Processing and workshop pre-fabrication.</p>	

IR-63 Plus[®] and IR-225 Plus[®] Fusion Jointing Machines



IR-63 Plus[®] Fully-Equipped Machine

Fully-equipped fusion jointing machine for welding SYGEF[®] Standard, SYGEF[®] Plus, DEKAPROP[®], PROGEF[®] Natural, PROGEF[®] Plus, PE 100 in dimensions d 20-63 mm with integrated remote welding unit.

Supply:

1-phase AC (50/60 Hz) 230 V L/N/PE

Delivery includes:

- Machine housing complete (1 pcs.)
- Heater assembly (1 pcs.)
- Remote weld device (1 pcs.)
- Facing tool (1 pcs.)
- Transport box (1 pcs.)
- Pipe stop (1 pcs.)
- Clamping inserts d 20-63 mm (8 pcs. per dimension)
- End caps PE d 20-63 mm (4 pcs. per dimension)
- Power supply cable 230 V (1 pcs.)
- Extension cable for remote weld device (1 pcs.)
- Extension cable for heater (1 pcs.)
- Extension cable for facing tool (1 pcs.)
- Cleaning brush No. 8 (1 pcs.)
- Hexagon key 3 mm (1 pcs.)
- Hexagon key 4 mm (1 pcs.)
- Heater protection shield (1 pcs.)
- Clamping unit extension (8 pcs.)
- Socket wrench (facing blades) (1 pcs.)
- Screw driver, Size 0 (1 pcs.)
- HP-Accessory Tray (1 pcs.)
- Manual (1 pcs.)

d-d [mm]	Code	kg	
20 - 63	790 131 005	52.000	

PF 2 43 412



IR-225 Plus® Fully-Equipped Machine with HP Working Table (HP = High Purity)

Fully-equipped fusion jointing machine for welding SYGEF® Standard, SYGEF® Plus, DEKAPROP®, PROGEF® Natural, PROGEF® Plus, PE 100 in dimensions d 63-225 mm.

Supply:

1-phase AC (50/60 Hz) 230 V L/N/PE or 3-phase AC (50/60 Hz) 400 V/230 V L1/L2/L3/N/PE

Delivery includes:

- Machine base (1 pcs.)
- Heater assembly (1 pcs.)
- Facing tool (1 pcs.)
- Working table, HP (1 pcs.)
- Movable clamping units (1 pcs.)
- Clamping inserts d 63-225 mm (8 pcs. per dimension)
- End caps PE d 63-225 mm (4 pcs. per dimension)
- Transportation lock (1 pcs.)
- Pipe stop (1 pcs.)
- Hexagon key 5 mm (1 pcs.)
- Hexagon key 6 mm (1 pcs.)
- Combination ring /open-jaw wrench 13 mm (1 pcs.)
- Cleaning brush (1 pcs.)
- Connecting cable 400 V - 230 V (1 pcs.)
- Ball for lever (1 pcs.)
- Manual (1 pcs.)

d-d [mm]	Code	kg	
63 - 225	790 133 009	453.000	

PF 2 43 414

IR-315 Plus[®] Fusion Jointing Machine

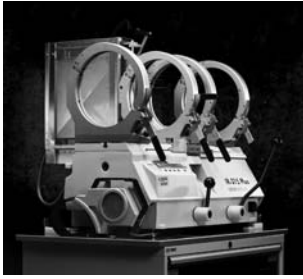

IR-315 Plus[®] Fully-Equipped Machine with HP Working Table (HP = High Purity)

Model:

- Fully-equipped fusion jointing machine for welding SYGEF[®] Standard, SYGEF[®] Plus in dimensions d 250-315.
- **Only a rental pool machine**

d-d [mm]		Code	
250 - 315	On request	-	

Accessories for the IR plastic fusion jointing machines



IR Plus® Win Weld

- The PC data transfer software makes it possible to manage and evaluate easily the recorded fusion data as required.
- **incl. Recordcard**

PF 2 43 278

	Code	kg	Pieces
WIN 2000/XP	790 131 471	0.245	1
WIN 95/98/Me	790 131 472	0.220	1



IR Plus® Recordcard

- Fusion data from the machine can be stored on an exchangeable protocol card (record card) with a storage capacity of approx. 900 fusion protocols. It allows a paperless documentation.

PF 2 43 412

Code	kg	Pieces
790 131 473	0.065	1



Clamping inserts

- The clamping inserts are different for each dimension. They are used to clamp and position the pipe components.

PF 2 43 412

d [mm]	Code	kg	Pieces
20	790 131 038	0.090	1
25	790 131 039	0.090	1
32	790 131 040	0.083	1
40	790 131 041	0.075	1
50	790 131 042	0.100	1
63	790 131 043	0.040	1



Clamping inserts

- The clamping inserts are different for each dimension. They are used to clamp and position the pipe components.

PF 2 43 414

d [mm]	Code	kg	Pieces
63	790 133 026	0.700	1
75	790 133 027	0.400	1
90	790 133 028	0.400	1
110	790 133 029	0.685	1
125	790 133 030	0.500	1
140	790 133 031	0.600	1
160	790 133 032	0.600	1
200	790 133 033	0.700	1
225	790 133 034	0.270	1



Set of facing knives

- A set includes two facing knives. Each facing knife has four blades. The blade may be turned three times before it must be replaced.

PF 2 43 412

d-d [mm]	Code	kg	Pieces
20 - 63	790 131 045	0.020	2



Set of facing knives

- A set includes two facing knives. Each facing knife has four blades. The blade may be turned three times before it must be replaced.

d-d [mm]	Code	kg	Pieces
63 - 225	790 133 046	0.120	2

PF 2 43 414



Set of end caps

- A set includes 4 end caps. The end caps are different for each dimension. The ends of the pipe **must** be closed. The caps prevent heat loss due to airflow in the fusion zone and guarantee optimum fusion results of the pipe components.

d [mm]	Code	kg	Pieces
63	790 131 035	0.035	4
75	790 133 036	0.090	4
90	790 133 037	0.110	4
110	790 133 038	0.180	4
125	790 133 039	0.150	4
140	790 133 040	0.180	4
160	790 133 041	0.290	4
200	790 133 042	0.460	4
225	790 133 043	0.400	4

PF 2 43 414



Set of end caps

- A set includes 4 end caps. The end caps are different for each dimension. The ends of the pipe **must** be closed. The caps prevent heat loss due to airflow in the fusion zone and guarantee optimum fusion results of the pipe components.

d [mm]	Code	kg	Pieces
20	790 131 030	0.010	4
25	790 131 031	0.010	4
32	790 131 032	0.015	4
40	790 131 033	0.025	4
50	790 131 034	0.055	4
63	790 131 035	0.035	4

PF 2 43 412



Movable clamping unit - left

- The movable, external clamping unit ensure high operating convenience. Short pipe pieces can be clamped on both sides.
- Included in the delivery when a new IR-225 Plus® is ordered.
- Previous IR 225 fusion jointing machines can be upgraded.

d-d [mm]	Code	kg	Pieces
63 - 225	790 133 061	10.700	1

PF 2 43 414



Movable clamping unit - right

- The movable, external clamping unit ensure high operating convenience. Short pipe pieces can be clamped on both sides.
- Included in the delivery when a new IR-225 Plus® is ordered.
- Previous IR 225 fusion jointing machines can be upgraded.

d-d [mm]	Code	kg	Pieces
63 - 225	790 133 062	10.200	1

PF 2 43 414



PF 2 43 412

Pipe stop

- The pipe stop defines the allowance when the pipes are clamped into position.

d-d [mm]	Code	kg	Pieces
20 - 63	790 131 046	0.430	1



PF 2 43 414

Pipe stop

- The pipe stop defines the allowance when the pipes are clamped into position.

d-d [mm]	Code	kg	Pieces
63 - 225	790 133 047	0.150	1



PF 2 43 412

Extension cable for clamping slide

- The extension cable enables the fusion e. g. under the ceiling.

d-d [mm]	Code	kg	Pieces
20 - 63	790 131 047	0.700	1



PF 2 43 412

Extension cable for facing tool

- The extension cable enables the fusion e. g. under the ceiling.

d-d [mm]	Code	kg	Pieces
20 - 63	790 131 048	0.438	1



PF 2 43 412

Extension cable for heater

- The extension cable enables the fusion e. g. under the ceiling.

d-d [mm]	Code	kg	Pieces
20 - 63	790 131 049	0.700	1



PF 2 43 412

Heater protection shield

- Protects the heater from plastic chips during the facing process.

Code	kg	Pieces
790 131 051	0.205	1

BCF® Plus Product Specifications

Fusion Technology	<p>Bead and crevice free fusion Software controlled, reproducible and monitored fusion and cooling process Remote fusion unit Pre-programmed and password protected fusion parameters Fusion protocol storage of 1600 fusions with unique fusion number Fusion factor → 0.98 User guidance in 8 languages Integrated error recognition Automated maintenance intervals Welder training and certification Voltage supply 110 V/230 V</p>
Piping material	<p>SYGEF® Plus (PVDF HP) SYGEF® Standard (PVDF Standard) PROGEF® Natural (PP Natural)</p>
Dimension	d20 (1/2") – d110 (4")
Pre-fusion treatment	<p>Cleaning with Tangit KS No inert gas required No filler material</p>
Surface finish in fusion zone	<p>SYGEF® Plus (PVDF HP) Ra ~ 0.25 µm SYGEF® Standard (PVDF Standard) Ra ~ 0.5 µm PROGEF® Natural (PP Natural) Ra ~ 0.8 µm</p>
Post-fusion treatment	<p>No manual welds No passivation No pickling</p>
Fusion documentation	<p>Print-out of 2 identical labels for labelling of piping system or isometric drawing</p> <ul style="list-style-type: none"> • Date • Joint number • Work site number • Welder / supervisor visa <p>Print-out of fusion protocol via A4 printer</p> <ul style="list-style-type: none"> • Date • Time • Machine number • Joint number • Operator • Work site • Process status • Chosen parameter (material, size, pipe series, PN, wall thickness) • Process parameter (temperature, time, pressure) • Confirmation and signature <p>Electronic record downloadable, write protected stored and administered via WIN WELD read out software.</p>
Testing and Inspection	<p>Sample fusions one per job site and dimension Fusion inspection with torch lamp based upon ASME BPE-a-2004.</p>
Conformances / Standards	<p>ASME BPE-a-2004 DVS 2203</p>
Main applications	<p>Uses include delivery of ultrapure water in pharmaceutical, medical and semiconductor grade water to highest purity and cleaning requirements as well a abrasive fluid transport in semiconductor and cosmetics.</p>

BCF[®] Plus Plastic Fusion Jointing Machine



BCF[®] Plus fully equipped machine d 20 - 63 mm

Fully-equipped machine for bead and crevice free jointing of SYGEF[®] Standard, SYGEF[®] Plus, PROGEF[®] Natural of the dimensions d 20-63 mm with integrated remote welding unit.

Supply:

1-phase AC (50/60 Hz) 115 / 230 V L/N/PE

Delivery includes:

- Machine housing (1 pcs.) incl. remote welding unit (1 pcs.)
- Transport box (1 pcs.)
- HP working table (1 pcs.)
- Heating stations d 20-63 mm (6 pcs.)
- Clamping units small (2 pcs.) with clamping inserts d 20-63 mm (24 pcs.)
- Facing tool small (1 pcs.) with facing inserts d 20-63 mm (6 pcs.)
- Facing tool support (1 pcs.)
- Hose box (1 pcs.) incl. air hose (1 pcs.)
- Supporting tools small d 20-63 mm (2 pcs.)
- BReT (1 pcs.)
- Hose cutter (1 pcs.)
- Air hose reducer (6-4 mm) (1 pcs.), air hose socket (4-4 mm) (1 pcs.)
- Extension cable (1 pcs.)
- Manual (1 pcs.)

d-d [mm]	Code	kg	
20 - 63	790 121 002	153.000	

PF 2 43 654



BCF[®] Plus fully-equipped machine d 20 -110 mm

Fully-equipped machine for bead and crevice free jointing of SYGEF[®] Standard, SYGEF[®] Plus, PROGEF[®] Natural of the dimensions d 20-110 mm with integrated remote welding unit.

Supply:

1-phase AC (50/60 Hz) 115 / 230 V L/N/PE

Delivery includes:

- Machine housing (1 pcs.) incl. remote welding unit (1 pcs.)
- Transport box (1 pcs.)
- HP working table (1 pcs.)
- Heating stations d 20-110 mm (9 pcs.)
- Clamping units small (2 pcs.) with clamping inserts d 20-63 mm (24 pcs.)
- Clamping units big (2 pcs.) with clamping inserts d 75-110 mm (12 pcs.)
- Adapter for clamping unit d 75-110 mm (2 pcs.)
- Facing tool small (1 pcs.) with facing inserts d 20-63 mm (6 pcs.)
- Facing tool big (1 pcs.) with facing inserts d 75-110 mm (3 pcs.)
- Facing tool support (1 pcs.)
- Hose box (1 pcs.) incl. air hose (1 pcs.)
- Supporting tools small d 20-63 mm (2 pcs.)
- Supporting tools big d 75-110 mm (2 pcs.)
- BReT (1 pcs.)
- Hose cutter (1 pcs.)
- Air hose reducer (6-4 mm) (1 pcs.), air hose socket (4-4 mm) (1 pcs.)
- Extension cable (1 pcs.)
- Manual (1 pcs.)

d-d [mm]	Code	kg	
20 - 110	790 121 001	188.000	

PF 2 43 654



Hose cutter

d-d [mm]	Code	kg	Pieces	
4 - 6	790 122 106	0.029	1	

PF 2 43 410



Reducer for compressed air hose

d-d [mm]	Code	kg	Pieces	
6 - 4	790 122 978	0.002	1	

PF 2 43 460



Socket for compressed air hose

Code	kg	Pieces	
790 122 104	0.006	1	

PF 2 43 410



BCF® Bladder for SYGEF® PVDF

- Only suitable for welding SYGEF® PVDF and not for PROGEF® Natural. **Silver bladder head!**

d [mm]	Code	kg	Pieces
20	790 122 041	0.014	1
25	790 122 042	0.029	1
32	790 122 043	0.037	1
40	790 122 044	0.055	1
50	790 122 045	0.108	1
63	790 122 046	0.152	1
75	790 121 047	0.152	1
90	790 121 048	0.204	1
110	790 121 049	0.428	1

PF 2 43 410



BCF® Plus Bladder

- Only suitable for welding PROGEF® Natural). **Blue bladder head** (except d 75 -110mm)!

d [mm]	Code	kg	Pieces
20	790 122 091	0.038	1
25	790 122 092	0.044	1
32	790 122 093	0.062	1
40	790 122 094	0.082	1
50	790 122 095	0.131	1
63	790 122 096	0.168	1
75	790 121 047	0.152	1
90	790 121 048	0.204	1
110	790 121 049	0.428	1

PF 2 43 410



BCF® Plus Win Weld

- The PC data transfer software makes it possible to manage and evaluate easily the recorded fusion data as required.
- **incl. Recordcard**

	Code	kg	Pieces
WIN 2000/XP	790 121 471	0.245	1
WIN 95/98/Me/NT	790 121 472	0.220	1

PF 2 43 278



BCF® Plus Recordcard

- Fusion data from the BCF® Plus- machine can be stored on an exchangeable protocol card (record card) with a storage capacity of approx. 900 fusion protocols. It allows a paperless documentation.

Code	kg
790 121 473	0.065

PF 2 43 412

SG 110 Socket fusion machine

For fusion jointing of PP, PE, PB and PVDF pipes and fittings

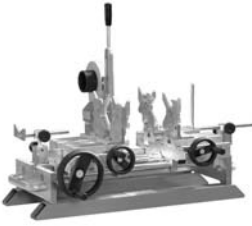

- Portable heating element - socket fusion machine for use in the workshop and on job sites.
- Dimension d 20 - 110 mm
- **Base machine**
- Compact, sturdy design, distortion-free machine bed
- Handwheel with torque locking mechanism for the slide movement
- **Heater**
- With electronic temperature control
- High temperature accuracy over the entire heating surface
- **Additional standard equipment on the basic model**
- Universal, left and right prismatic clamping devices, complete, for clamping pipe and fittings. Additional set of prismatic clamping devices for outer clamping of pipes available as an option.
- Depth stop
- V-shaped pipe support d 20 - 110 mm
- Back stop
- Machine specific tool set
- Timer to clock fusion times

d-d [mm]	Performance	Code	kg	
20 - 110	230 V/1200 W	790 310 001	65.000	
20 - 110	115 V/1200 W	790 310 003	64.000	

PF 3 25 134

SG 110 Accessories

Heating spigots and bushes



- For socket fusion systems in PP, PE and PVDF
- Always delivered in pairs (also usable for SG 110, not for SG 160)
- Type B

d [mm]	Code	kg
20	799 300 156	0.080
25	799 300 157	0.110
32	799 300 158	0.140
40	799 300 159	0.230
50	799 300 160	0.335
63	799 300 161	0.660
75	799 300 162	0.965
90	799 300 163	1.440
110	799 300 164	2.210

PF 3 25 117

Manual pipe peeling tool



- For socket fusion systems in PP, PE and PVDF

d [mm]	Code	kg
20	799 300 260	0.059
25	799 300 270	0.074
32	799 300 280	0.100
40	799 300 290	0.259
50	799 300 300	0.299
63	799 300 310	0.513
75	799 300 320	0.750
90	799 300 330	1.070
110	799 300 340	1.350

Chamfering tool

d-d [mm]	Code	kg
40 - 200	790 309 001	1.600
50 - 315	790 309 002	3.170

PF 3 10 590

SG 110 Special accessories

Universal prismatic clamping device, complete



- For correct clamping of long pipes, fittings
- 1 set = 2 pieces (1 back and 1 front prismatic clamping device) for mounting on left or right side, as well as for inner and outer mounting

PF 3 25 134

d-d [mm]	Code	kg
20 - 110	790 310 011	3.300

Backstop, complete



- Prevents the components from slipping out of the clamping device during fusion.

PF 3 25 117

d-d [mm]	Code	kg
20 - 110	790 310 012	0.600

V-shaped pipe support, complete



PF 3 25 117

d-d [mm]	Code	kg
20 - 110	790 310 013	0.700

Heating element



- E = electronic
- T = thermostatic

PF 3 25 117

d-d [mm]	Performance	Code	kg
20 - 110	230 V/1200 W E	790 310 014	2.400
20 - 110	230 V/1200 W T	790 310 015	2.400
20 - 110	115 V/1200 W E	790 310 016	2.400
20 - 110	115 V/1200 W T	790 310 017	2.400

Special transport crate



PF 3 25 117

Code	kg
790 310 099	45.000

1 set face chucks



- For back and front prismatic clamping device (set of 2 pieces)

PF 3 25 117

d-d [mm]	Code	kg
20 - 110	790 310 018	-

Preparation Tools & Accessories

PPC Plastic Pipe Cutter

V7

- For cutting plastic pipes d10 - d160



PF 3 25 117

d-d [mm]	Article	Code	kg
10 - 63	PPC 63, s max. = 7,2mm	790 109 001	0.710
50 - 110	PPC 110, s max. = 12.7mm	790 109 002	1.400
110 - 160	PPC 160, s max. = 19,0mm	790 109 003	1.880

Manual Pipe Peeling Tool for Socket Fusion



PF 2 51 305

d [mm]	Code	kg
20	799 300 260	0.059
25	799 300 270	0.074
32	799 300 280	0.100
40	799 300 290	0.259
50	799 300 300	0.299
63	799 300 310	0.513
75	799 300 320	0.750
90	799 300 330	1.070
110	799 300 340	1.350

KS Tangit Cleaner

F

- Special cleaning agent for plastic fusion connections with PP, PE, PVDF and PB.



PF 2 28 473

Code	kg
799 298 023	0.890

Cleaning tissue KO-TON-R

- This cleaning tissue is suitable for the cleaning of the welding zone of piping components, because it is lint free and clean room checked.

1) Minimum order quantity 50 pieces



Code	kg
790 122 085	0.004

Standards and Conformances – SYGEF®

GF SYGEF Plus & SYGEF Standard, and the IR-Plus & BCF-Plus Fusion methods

SYGEF PVDF is compliant with the following international & industry standards:

- FDA CFR 21 § 177.2510
- USP 24, 26 Class VI
- ASME-BPE-PM – 2004 (incl. BCF fusion method)
- SEMI F57
- FM 4910
- UL 94 V-0, UL 723 / ASTM E84 (flame retardant)
- DVS 2205-4
- DVS 2207-6
- DVS 2207-15
- EN ISO 10931

→ Note that some compliances are only applicable to SYGEF-Plus components.

PVDF piping joined with BCF® fusion technology is also included in ISPE Baseline Vol 4, “Water & Steam Systems” technical guide

Production certification through EN2.2 & EN3.1b certificates is available on request.

In the following pages you will find our most commonly requested certificates:

- FDA Compliance of SYGEF Plus & SYGEF Standard
- USP VI Compliance of SYGEF Plus & SYGEF Standard
- FDA Compliance of PTFE Diaphragm from GF Diaphragm Valves
- USP VI Compliance of PTFE Diaphragm from GF Diaphragm Valves
- FDA Compliance of FPM-White o-ring from SYGEF-Plus Unions/Valves
- USP VI Compliance of FPM-White o-ring from SYGEF-Plus Unions/Valves
- FDA Compliance of BCF Fusion Technology
- ASME-BPE-PM Compliance of BCF Fusion Technology

Further certificates for SYGEF PVDF are available on request only, please contact GF.

Certificate of Conformity

We hereby certify that

+GF+ SYGEF[®] Plus and SYGEF[®] Standard

are manufactured from PVDF (polyvinylidene fluoride) compound Kynar[®] 720, Kynar[®] 740 and Solef[®] 1008 which comply with the requirements of the American Food and Drug Administration (FDA), Code of Federal Regulations (Food and Drugs), paragraph 21 177.2510.

Date 15. 06. 2004



Christian Classen
Product Manager PVDF



Katrin Wallheinke
Manager Materials Technology

+GF+

GEORG FISCHER
PIPING SYSTEMS

Certificate of Conformity

We hereby certify that

+GF+ SYGEF[®] Plus and SYGEF[®] Standard (PVDF)

are manufactured from compound Kynar[®] 740 and Solef[®] 1008 which have been tested and certified by NAMS Northwood Ohio to be in compliance with the criteria of the Class VI United States Pharmacopeia Biological Reactivity Tests, in vivo.

Date 15. 06. 2004



Christian Classen
Product Manager PVDF



Katrin Wallheinke
Manager Materials Technology

+GF+

GEORG FISCHER
PIPING SYSTEMS

Certificate of Conformity

We hereby certify that

+GF+ Diaphragm Valves Type 314, 315, 317, 319

equipped with PTFE Diaphragm

**are manufactured from compound PTFE 9900/4562
which comply with the requirements of the American
Food and Drug Administration (FDA), Code of Federal
Regulations (Food and Drugs), paragraph 177.1550.**

Date 15. 06. 2004



Rainer Kech
Product Manager
Diaphragm Valves, Actuators, AS-i



Michael Hollfeld
Project Manager

+GF+

GEORG FISCHER
PIPING SYSTEMS

Certificate of Conformity

We hereby certify that

+GF+ Diaphragm Valves Type 314, 315, 317, 319

equipped with PTFE Diaphragm

are manufactured from compound PTFE 9900/4562
which has been tested and certified by NAMSA
Northwood Ohio to be in compliance with the criteria of
the Class VI United States Pharmacopeia Biological
Reactivity Tests, in vivo.

Date 15. 06. 2004



Rainer Kech
Product Manager
Diaphragm Valves, Actuators, AS-i



Michael Hollfeld
Project Manager

Certificate of Conformity

We hereby certify that

+GF+ SYGEF[®] Plus Union O-rings FPM white

are manufactured from FPM 75 white (fluoro elastomer) which comply with the requirements of the American Food and Drug Administration (FDA), Code of Federal Regulations (Food and Drugs), paragraph 177.2600.

Date 15. 06. 2004



Christian Classen
Product Manager PVDF



Michael Hollfeld
Project Manager

+GF+

GEORG FISCHER
PIPING SYSTEMS

Certificate of Conformity

We hereby certify that

+GF+ SYGEF[®] Plus Union O-rings FPM white

are manufactured from FPM 75 white (fluoro elastomer)
which has been tested and certified by NAMSA
Northwood Ohio to be in compliance with the criteria of
the Class VI United States Pharmacopeia Biological
Reactivity Tests, in vivo.

Date 15. 06. 2004

Christian Classen
Product Manager PVDF

Michael Hollfeld
Project Manager

Georg Fischer Ltd,
Ebnatstrasse 111, P.O. Box,
CH-8201 Schaffhausen/Switzerland
Phone +41 (0)52-631 11 11, Fax +41 (0)52-631 28 37
info@piping.georgfischer.com, www.piping.georgfischer.com

Certificate of Conformity

We hereby certify that

+GF+ BCF® Plus Welding Technology

meets the requirements of the American Food and Drug Administration (FDA), for jointing methods, i.e. that the joints be smooth with no cracks, crevices or pits. Acceptable joint quality can be defined, inspected and documented.



Felix Meier
Product Manager
Fusion Maschines (IR/BCF)



Jörg Wermelinger
Manager PMD VT



GEORG FISCHER
PIPING SYSTEMS

Quality Assurance

George Fischer, Inc.
2882 Dow Avenue
Tustin, California 92780-7258
USA
Phone +1 (714) 731-8800
Toll free (800) 854-4090
Fax +1 (714) 731-6201
info@us.piping.georgefischer.com
www.us.piping.georgefischer.com

Certificate of Conformance

George Fischer Piping confirms that the items listed below conform with the requirements of ASME-BPE 2005, Sections PM-1 through PM5 by means of acceptable material, design and conformance of joint quality documented and verified through inspection.

+GF+ BCF[®]Plus Welding Technology in conjunction with piping systems of:

- +GF+ SYGEF[®]Plus (PVDF-HP)
- +GF+ SYGEF[®]Standard (PVDF-Standard)
- +GF+ PROGEF[®]Natural (PP-Natural)

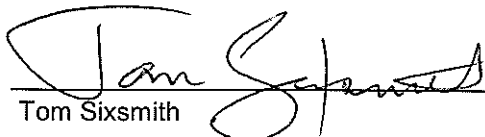

Tom Sixsmith

VP Custom Products

BPE Committee Member, Materials and Joining

9-25-06

Date

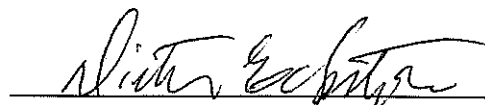

Dieter Eckstein

Quality Assurance Manager

9/26/06

Date

Index

Code	Page
155 522 554	241
155 522 555	241
155 522 556	241
155 522 579	241
155 522 580	241
155 522 581	241
161 486 435	57
161 486 436	57
161 486 437	57
161 486 438	57
161 486 443	57
161 486 444	57
161 486 445	57
161 486 446	57
167 482 626	53
167 482 627	53
167 482 628	53
167 482 629	53
167 482 635	54
167 482 636	54
167 482 637	54
167 482 638	54
167 482 653	55
167 482 654	55
167 482 655	55
167 482 656	55
167 482 662	55
167 482 663	55
167 482 664	55
167 482 665	55
167 482 671	54
167 482 672	54
167 482 673	54
167 482 674	54
167 482 680	53
167 482 681	53
167 482 682	53
167 482 683	53
167 484 100	56
167 484 101	56
167 484 102	56
167 484 103	56
167 484 104	56
167 484 105	56
167 484 110	56
167 484 111	56
175 314 362	234
175 314 363	234
175 314 364	234
175 314 365	234
175 314 366	234
175 314 367	234
175 314 432	63
175 314 433	63
175 314 434	63
175 314 435	63
175 314 436	63
175 314 437	63
175 314 532	63
175 314 533	63
175 314 534	63
175 314 535	63
175 314 536	63
175 314 537	63
175 314 662	234
175 314 663	234
175 314 664	234

Code	Page
175 314 665	234
175 314 666	234
175 314 667	234
175 315 368	235
175 315 432	64
175 315 433	64
175 315 434	64
175 315 435	64
175 315 436	64
175 315 437	64
175 315 532	64
175 315 533	64
175 315 534	64
175 315 535	64
175 315 536	64
175 315 537	64
175 315 562	235
175 315 563	235
175 315 564	235
175 315 565	235
175 315 566	235
175 315 567	235
175 315 602	235
175 315 603	235
175 315 604	235
175 315 605	235
175 315 606	235
175 315 607	235
175 317 009	65
175 317 010	65
175 317 012	65
175 317 054	236
175 317 055	236
175 317 057	236
175 317 339	66
175 317 340	66
175 317 355	237
175 317 432	65
175 317 433	65
175 317 434	65
175 317 435	65
175 317 436	65
175 317 437	65
175 317 438	65
175 317 447	236
175 317 448	236
175 317 449	236
175 317 450	236
175 317 451	236
175 317 452	236
175 317 453	236
175 317 532	66
175 317 533	66
175 317 534	66
175 317 535	66
175 317 536	66
175 317 537	66
175 317 538	66
175 317 562	237
175 317 563	237
175 317 564	237
175 317 565	237
175 317 566	237
175 317 567	237
175 317 568	237
175 319 301	238
175 319 303	238

Code	Page
175 319 304	238
175 319 307	238
175 319 308	238
175 319 309	238
175 319 312	238
175 319 313	238
175 319 314	238
175 319 315	238
175 319 318	238
175 319 319	238
175 319 320	238
175 319 321	238
175 319 322	238
175 319 325	238
175 319 326	238
175 319 327	238
175 319 328	238
175 319 329	238
175 319 330	238
175 319 336	238
175 319 337	238
175 319 338	238
175 319 341	238
175 319 342	238
175 319 343	238
175 319 345	238
175 319 346	238
175 319 351	238
175 319 352	238
175 319 353	238
175 319 355	238
175 319 356	238
175 319 601	240
175 319 603	240
175 319 604	240
175 319 607	240
175 319 608	240
175 319 609	240
175 319 612	240
175 319 613	240
175 319 614	240
175 319 615	240
175 319 618	240
175 319 619	240
175 319 620	240
175 319 621	240
175 319 622	240
175 319 625	240
175 319 626	240
175 319 627	240
175 319 628	240
175 319 629	240
175 319 630	240
175 319 636	240
175 319 637	240
175 319 638	240
175 319 641	240
175 319 642	240
175 319 643	240
175 319 645	240
175 319 646	240
175 319 651	240
175 319 652	240
175 319 653	240
175 319 655	240
175 319 656	240
175 343 011	58

Index

Code	Page
175 343 012	58
175 343 013	58
175 343 014	58
175 343 015	58
175 343 016	58
175 343 017	58
175 343 031	59
175 343 032	59
175 343 033	59
175 343 034	59
175 343 035	59
175 343 036	59
175 343 037	59
175 343 051	58
175 343 052	58
175 343 053	58
175 343 054	58
175 343 055	58
175 343 056	58
175 343 057	58
175 343 071	60
175 343 072	60
175 343 073	60
175 343 074	60
175 343 075	60
175 343 076	60
175 343 077	60
175 343 111	61
175 343 112	61
175 343 113	61
175 343 114	61
175 343 115	61
175 343 116	61
175 343 117	61
175 343 131	62
175 343 132	62
175 343 133	62
175 343 134	62
175 343 135	62
175 343 136	62
175 343 137	62
175 343 151	60
175 343 152	60
175 343 153	60
175 343 154	60
175 343 155	60
175 343 156	60
175 343 157	60
175 343 171	62
175 343 172	62
175 343 173	62
175 343 174	62
175 343 175	62
175 343 176	62
175 343 177	62
175 360 411	76
175 360 412	76
175 360 413	76
175 360 414	76
175 360 415	76
175 360 416	76
175 360 417	76
175 360 451	77
175 360 452	77
175 360 453	77
175 360 454	77
175 360 455	77

Code	Page
175 360 456	77
175 360 457	77
175 360 492	76
175 360 493	76
175 360 494	76
175 360 495	76
175 360 496	76
175 360 497	76
175 360 611	84
175 360 612	84
175 360 613	84
175 360 614	84
175 360 615	84
175 360 616	84
175 360 617	84
175 360 631	85
175 360 632	85
175 360 633	85
175 360 634	85
175 360 635	85
175 360 636	85
175 360 637	85
175 360 671	84
175 360 672	84
175 360 673	84
175 360 674	84
175 360 675	84
175 360 676	84
175 360 677	84
175 369 022	78
175 369 023	78
175 369 024	78
175 369 025	78
175 369 026	78
175 369 027	78
175 369 029	78
175 369 030	78
175 369 031	78
175 369 032	78
175 369 033	78
175 369 062	79
175 369 063	79
175 369 064	79
175 369 065	79
175 369 066	79
175 369 067	79
175 369 069	79
175 369 070	79
175 369 071	79
175 369 072	79
175 369 073	79
175 369 102	80
175 369 103	80
175 369 104	80
175 369 105	80
175 369 106	80
175 369 107	80
175 369 109	80
175 369 110	80
175 369 111	80
175 369 112	80
175 369 113	80
175 480 202	12
175 480 203	12
175 480 204	12
175 480 205	12
175 480 206	12

Code	Page
175 480 207	12
175 480 208	12
175 480 209	12
175 480 210	12
175 480 211	12
175 480 213	12
175 480 214	12
175 480 216	12
175 480 217	12
175 480 318	287
175 480 319	287
175 480 320	287
175 480 321	287
175 480 322	287
175 480 323	287
175 480 324	287
175 480 656	12
175 480 665	12
175 480 666	12
175 480 667	12
175 480 668	12
175 480 669	12
175 480 670	12
175 480 671	12
175 480 673	12
175 480 674	12
175 481 202	211
175 481 203	211
175 481 204	211
175 481 205	211
175 481 206	211
175 481 207	211
175 481 208	211
175 481 209	211
175 481 210	211
175 481 211	211
175 481 212	211
175 481 213	211
175 481 214	211
175 481 216	211
175 481 217	211
175 481 656	211
175 481 665	211
175 481 666	211
175 481 667	211
175 481 668	211
175 481 669	211
175 481 670	211
175 481 671	211
175 481 673	211
175 481 674	211
175 482 101	20
175 482 102	20
175 482 103	20
175 482 105	20
175 482 106	20
175 483 459	285
175 483 461	285
175 483 464	285
175 483 466	285
175 483 468	285
175 483 470	285
175 483 472	285
175 546 051	49
175 546 052	49
175 546 053	49
175 546 054	49

Index

Code	Page	Code	Page	Code	Page
175 546 055	49	175 567 026	68	198 806 466	208
175 546 056	49	175 567 027	68	198 806 467	208
175 546 057	49	175 567 028	68	198 806 468	208
175 546 192	50	175 567 822	69	198 806 469	208
175 546 193	50	175 567 823	69	198 806 470	208
175 546 194	50	175 567 824	69	198 806 471	208
175 546 195	50	175 567 825	69	198 806 472	208
175 546 196	50	175 567 826	69	198 806 473	208
175 546 197	50	175 567 827	69	199 025 321	158
175 546 272	47	175 567 828	69	199 025 322	158
175 546 273	47	175 568 002	70	199 025 323	158
175 546 274	47	175 568 003	70	199 025 324	158
175 546 275	47	175 568 004	70	199 025 325	158
175 546 276	47	175 568 005	70	199 025 326	158
175 546 277	47	175 568 006	70	199 025 327	163
175 546 331	51	175 568 007	70	199 025 329	163
175 546 332	51	175 568 008	70	199 025 331	166
175 546 333	51	175 568 022	71	199 025 332	166
175 546 334	51	175 568 023	71	199 025 333	166
175 546 335	51	175 568 024	71	199 025 334	166
175 546 336	51	175 568 025	71	199 025 335	166
175 546 337	51	175 568 026	71	199 025 336	166
175 546 411	48	175 568 027	71	199 025 337	171
175 546 412	48	175 568 028	71	199 025 339	171
175 546 413	48	175 568 102	73	199 025 341	174
175 546 414	48	175 568 103	73	199 025 342	174
175 546 415	48	175 568 104	73	199 025 343	174
175 546 416	48	175 568 105	73	199 025 344	174
175 546 417	48	175 568 106	73	199 025 345	174
175 546 431	52	175 568 107	73	199 025 346	174
175 546 432	52	175 568 108	73	199 025 347	179
175 546 433	52	175 568 122	74	199 025 349	179
175 546 434	52	175 568 123	74	199 025 351	160
175 546 435	52	175 568 124	74	199 025 352	160
175 546 436	52	175 568 125	74	199 025 353	160
175 546 437	52	175 568 126	74	199 025 354	160
175 546 471	81	175 568 127	74	199 025 355	160
175 546 472	81	175 568 128	74	199 025 356	160
175 546 473	81	175 568 822	72	199 025 357	161
175 546 474	81	175 568 823	72	199 025 358	161
175 546 475	81	175 568 824	72	199 025 359	161
175 546 476	81	175 568 825	72	199 025 361	168
175 546 477	81	175 568 826	72	199 025 362	168
175 546 691	83	175 568 827	72	199 025 363	168
175 546 692	83	175 568 828	72	199 025 364	168
175 546 693	83	175 568 922	75	199 025 365	168
175 546 694	83	175 568 923	75	199 025 366	168
175 546 695	83	175 568 924	75	199 025 367	169
175 546 696	83	175 568 925	75	199 025 368	169
175 546 697	83	175 568 926	75	199 025 369	169
175 546 752	82	175 568 927	75	199 025 370	169
175 546 753	82	175 568 928	75	199 025 371	176
175 546 754	82	198 801 202	281	199 025 372	176
175 546 755	82	198 801 203	281	199 025 373	176
175 546 756	82	198 801 204	281	199 025 374	176
175 546 757	82	198 801 205	281	199 025 375	176
175 567 002	67	198 801 206	281	199 025 376	176
175 567 003	67	198 801 207	281	199 025 377	177
175 567 004	67	198 801 208	281	199 025 378	177
175 567 005	67	198 803 905	208	199 025 379	177
175 567 006	67	198 803 906	208	199 025 380	177
175 567 007	67	198 803 907	208	199 025 387	252
175 567 008	67	198 803 908	208	199 025 389	252
175 567 022	68	198 803 909	208	199 025 397	264
175 567 023	68	198 803 910	208	199 025 399	264
175 567 024	68	198 803 911	208	199 025 407	272
175 567 025	68	198 803 912	208	199 025 409	272

Index

Code	Page
199 025 441	249
199 025 442	249
199 025 443	249
199 025 444	249
199 025 445	249
199 025 446	249
199 025 447	250
199 025 448	250
199 025 449	250
199 025 451	261
199 025 452	261
199 025 453	261
199 025 454	261
199 025 455	261
199 025 456	261
199 025 457	262
199 025 458	262
199 025 459	262
199 025 460	262
199 025 461	269
199 025 462	269
199 025 463	269
199 025 464	269
199 025 465	269
199 025 466	269
199 025 467	270
199 025 468	270
199 025 469	270
199 025 470	270
199 025 601	162
199 025 602	162
199 025 603	162
199 025 604	162
199 025 605	162
199 025 606	162
199 025 611	170
199 025 612	170
199 025 613	170
199 025 614	170
199 025 615	170
199 025 616	170
199 025 621	178
199 025 622	178
199 025 623	178
199 025 624	178
199 025 625	178
199 025 626	178
199 025 971	247
199 025 972	247
199 025 973	247
199 025 974	247
199 025 975	247
199 025 976	247
199 025 977	259
199 025 978	259
199 025 979	259
199 025 980	259
199 025 981	259
199 025 982	259
199 025 983	267
199 025 984	267
199 025 985	267
199 025 986	267
199 025 987	267
199 025 988	267
199 027 321	159
199 027 322	159

Code	Page
199 027 323	159
199 027 324	159
199 027 325	159
199 027 326	159
199 027 331	167
199 027 332	167
199 027 333	167
199 027 334	167
199 027 335	167
199 027 336	167
199 027 341	175
199 027 342	175
199 027 343	175
199 027 344	175
199 027 345	175
199 027 346	175
199 027 401	248
199 027 402	248
199 027 403	248
199 027 404	248
199 027 405	248
199 027 406	248
199 027 411	260
199 027 412	260
199 027 413	260
199 027 414	260
199 027 415	260
199 027 416	260
199 027 421	268
199 027 422	268
199 027 423	268
199 027 424	268
199 027 425	268
199 027 426	268
199 027 491	157
199 027 492	157
199 027 493	157
199 027 494	157
199 027 495	157
199 027 496	157
199 027 501	165
199 027 502	165
199 027 503	165
199 027 504	165
199 027 505	165
199 027 506	165
199 027 511	173
199 027 512	173
199 027 513	173
199 027 514	173
199 027 515	173
199 027 516	173
199 027 581	251
199 027 582	251
199 027 583	251
199 027 584	251
199 027 585	251
199 027 586	251
199 027 591	263
199 027 592	263
199 027 593	263
199 027 594	263
199 027 595	263
199 027 596	263
199 027 601	271
199 027 602	271
199 027 603	271

Code	Page
199 027 604	271
199 027 605	271
199 027 606	271
199 027 731	255
199 027 732	255
199 027 733	255
199 027 734	255
199 027 735	255
199 027 736	255
199 027 741	265
199 027 742	265
199 027 743	265
199 027 744	265
199 027 745	265
199 027 746	265
199 027 751	275
199 027 752	275
199 027 753	275
199 027 754	275
199 027 755	275
199 027 756	275
199 027 771	255
199 027 772	255
199 027 773	255
199 027 774	255
199 027 775	255
199 027 776	255
199 027 781	265
199 027 782	265
199 027 783	265
199 027 784	265
199 027 785	265
199 027 786	265
199 027 791	275
199 027 792	275
199 027 793	275
199 027 794	275
199 027 795	275
199 027 796	275
199 027 811	257
199 027 812	257
199 027 813	257
199 027 814	257
199 027 815	257
199 027 816	257
199 027 817	257
199 027 818	257
199 027 819	257
199 027 820	257
199 027 821	257
199 027 822	257
199 027 823	257
199 027 824	257
199 027 825	257
199 027 826	257
199 027 827	257
199 027 828	257
199 027 829	257
199 027 830	257
199 027 831	257
199 027 832	257
199 027 833	257
199 027 834	257
199 027 835	257
199 027 836	257
199 027 837	257
199 027 838	257

Index

Code	Page
199 027 839	257
199 027 840	257
199 027 841	257
199 027 842	257
199 027 843	257
199 027 844	257
199 027 971	156
199 027 972	156
199 027 973	156
199 027 974	156
199 027 975	156
199 027 976	156
199 027 977	164
199 027 978	164
199 027 979	164
199 027 980	164
199 027 981	164
199 027 982	164
199 027 983	172
199 027 984	172
199 027 985	172
199 027 986	172
199 027 987	172
199 027 988	172
199 028 067	273
199 028 068	273
199 028 069	273
199 028 070	273
199 028 077	273
199 028 078	273
199 028 079	273
199 028 080	273
199 028 087	273
199 028 088	273
199 028 089	273
199 028 090	273
199 028 097	273
199 028 098	273
199 028 099	273
199 028 100	273
199 028 107	273
199 028 108	273
199 028 109	273
199 028 110	273
199 028 117	273
199 028 118	273
199 028 119	273
199 028 120	273
199 028 137	273
199 028 138	273
199 028 139	273
199 028 157	273
199 028 158	273
199 028 159	273
199 028 160	273
199 028 177	273
199 028 178	273
199 028 179	273
199 028 193	153
199 028 194	153
199 028 195	153
199 028 196	153
199 028 197	153
199 028 198	153
199 028 321	152
199 028 322	152
199 028 323	152

Code	Page
199 028 324	152
199 028 325	152
199 028 326	152
199 028 351	154
199 028 352	154
199 028 353	154
199 028 354	154
199 028 355	154
199 028 356	154
199 028 361	155
199 028 362	155
199 028 363	155
199 028 364	155
199 028 365	155
199 028 366	155
199 028 401	244
199 028 402	244
199 028 403	244
199 028 404	244
199 028 405	244
199 028 406	244
199 028 441	245
199 028 442	245
199 028 443	245
199 028 444	245
199 028 445	245
199 028 446	245
199 028 491	151
199 028 492	151
199 028 493	151
199 028 494	151
199 028 495	151
199 028 496	151
199 028 581	246
199 028 582	246
199 028 583	246
199 028 584	246
199 028 585	246
199 028 586	246
199 028 961	150
199 028 962	150
199 028 963	150
199 028 964	150
199 028 965	150
199 028 966	150
199 028 971	243
199 028 972	243
199 028 973	243
199 028 974	243
199 028 975	243
199 028 976	243
199 029 341	253
199 029 342	253
199 029 343	253
199 029 344	253
199 029 345	253
199 029 346	253
199 029 347	253
199 029 348	253
199 029 349	253
199 029 350	253
199 029 351	253
199 029 352	253
199 029 353	253
199 029 354	253
199 029 355	253
199 029 356	253

Code	Page
199 029 357	253
199 029 358	253
199 029 359	253
199 029 360	253
199 029 361	253
199 029 362	253
199 029 363	253
199 029 364	253
199 029 365	253
199 029 366	253
199 029 367	253
199 029 368	253
199 029 369	253
199 029 370	253
199 029 371	253
199 029 372	253
199 029 373	253
199 029 374	253
199 041 004	205
199 041 005	205
199 041 052	201
199 041 053	201
199 041 054	201
199 041 055	201
199 041 056	201
199 041 057	201
199 041 058	201
199 041 059	201
199 041 084	201
199 041 085	201
199 041 086	201
199 041 087	201
199 041 088	201
199 041 089	201
199 041 114	202
199 041 115	202
199 041 116	202
199 041 117	202
199 041 118	202
199 041 119	202
199 041 138	206
199 041 139	206
199 041 140	206
199 041 141	206
199 041 142	206
199 041 143	206
199 041 144	206
199 041 145	206
199 041 146	206
199 041 184	278
199 041 185	278
199 041 186	278
199 041 187	278
199 041 188	278
199 041 189	278
199 041 192	278
199 041 193	278
199 041 194	278
199 041 195	278
199 041 196	278
199 041 198	279
199 041 199	279
199 041 200	279
199 041 201	279
199 041 202	279
199 041 231	207
199 041 232	207

Index

Code	Page
199 041 233	207
199 041 234	207
199 041 235	207
199 041 236	207
199 041 237	207
199 041 256	207
199 041 257	207
199 041 258	207
199 041 259	207
199 041 260	207
199 041 261	207
199 041 262	207
199 041 263	207
199 041 264	207
199 041 283	206
199 041 284	206
199 041 285	206
199 041 286	206
199 041 287	206
199 041 288	206
199 041 289	206
199 041 290	206
199 041 291	206
199 041 296	205
199 041 297	205
199 041 323	203
199 041 324	203
199 041 325	203
199 041 326	203
199 041 327	203
199 041 328	203
199 041 329	203
199 041 344	204
199 041 345	204
199 041 346	204
199 041 347	204
199 041 348	204
199 041 349	204
199 041 350	204
199 041 395	279
199 041 396	279
199 041 397	279
199 041 398	279
199 041 399	279
199 041 400	279
199 041 520	280
199 041 521	280
199 041 522	280
199 041 523	280
199 041 524	280
199 041 525	280
199 041 661	202
199 041 662	202
199 041 663	202
199 041 664	202
199 041 665	202
199 041 666	202
199 041 892	203
199 041 898	204
199 107 423	86
199 107 424	86
199 107 425	86
199 107 426	86
199 107 427	86
199 107 428	86
199 107 433	90
199 107 434	90

Code	Page
199 107 435	90
199 107 436	90
199 107 437	90
199 107 438	90
199 107 802	87
199 107 803	87
199 107 804	87
199 107 805	87
199 107 806	87
199 107 807	87
199 107 808	87
199 107 812	88
199 107 813	88
199 107 814	88
199 107 815	88
199 107 816	88
199 107 817	88
199 107 818	88
199 107 822	91
199 107 823	91
199 107 824	91
199 107 825	91
199 107 826	91
199 107 827	91
199 107 828	91
199 107 832	92
199 107 833	92
199 107 834	92
199 107 835	92
199 107 836	92
199 107 837	92
199 107 838	92
199 107 843	89
199 107 844	89
199 107 845	89
199 107 846	89
199 107 847	89
199 107 848	89
199 107 853	93
199 107 854	93
199 107 855	93
199 107 856	93
199 107 857	93
199 107 858	93
199 132 012	95
199 132 013	95
199 132 014	95
199 132 015	95
199 132 016	95
199 132 017	95
199 132 018	95
199 132 032	96
199 132 033	96
199 132 034	96
199 132 035	96
199 132 036	96
199 132 037	96
199 132 038	96
199 132 052	99
199 132 053	99
199 132 054	99
199 132 055	99
199 132 056	99
199 132 057	99
199 132 058	99
199 132 072	100
199 132 073	100

Code	Page
199 132 074	100
199 132 075	100
199 132 076	100
199 132 077	100
199 132 078	100
199 132 083	97
199 132 084	97
199 132 085	97
199 132 086	97
199 132 087	97
199 132 088	97
199 132 093	101
199 132 094	101
199 132 095	101
199 132 096	101
199 132 097	101
199 132 098	101
199 132 113	94
199 132 114	94
199 132 115	94
199 132 116	94
199 132 117	94
199 132 118	94
199 132 153	98
199 132 154	98
199 132 155	98
199 132 156	98
199 132 157	98
199 132 158	98
199 140 562	181
199 140 563	181
199 140 564	181
199 140 565	181
199 140 566	181
199 140 567	181
199 140 568	181
199 140 582	180
199 140 583	180
199 140 584	180
199 140 585	180
199 140 586	180
199 140 587	180
199 140 588	180
199 140 602	183
199 140 603	183
199 140 604	183
199 140 605	183
199 140 606	183
199 140 607	183
199 140 608	183
199 140 622	182
199 140 623	182
199 140 624	182
199 140 625	182
199 140 626	182
199 140 627	182
199 140 628	182
199 141 582	184
199 141 583	184
199 141 584	184
199 141 585	184
199 141 586	184
199 141 587	184
199 141 588	184
199 141 622	185
199 141 623	185
199 141 624	185

Index

Code	Page
199 141 625	185
199 141 626	185
199 141 627	185
199 141 628	185
199 142 582	186
199 142 583	186
199 142 584	186
199 142 585	186
199 142 586	186
199 142 587	186
199 142 588	186
199 142 622	187
199 142 623	187
199 142 624	187
199 142 625	187
199 142 626	187
199 142 627	187
199 142 628	187
199 165 402	197
199 165 403	197
199 165 404	197
199 165 405	197
199 165 406	197
199 165 407	197
199 165 412	197
199 165 413	197
199 165 414	197
199 165 415	197
199 165 416	197
199 165 417	197
199 165 422	197
199 165 423	197
199 165 424	197
199 165 425	197
199 165 426	197
199 165 427	197
199 165 432	197
199 165 433	197
199 165 434	197
199 165 435	197
199 165 436	197
199 165 437	197
199 165 442	197
199 165 443	197
199 165 444	197
199 165 445	197
199 165 446	197
199 165 447	197
199 165 452	197
199 165 453	197
199 165 454	197
199 165 455	197
199 165 456	197
199 165 457	197
199 166 505	198
199 166 506	198
199 166 507	198
199 166 515	199
199 166 516	199
199 166 517	199
199 166 656	199
199 166 666	200
199 177 012	104
199 177 013	104
199 177 014	104
199 177 015	104
199 177 016	104

Code	Page
199 177 017	104
199 177 018	104
199 177 032	110
199 177 033	110
199 177 034	110
199 177 035	110
199 177 036	110
199 177 037	110
199 177 038	110
199 177 052	102
199 177 053	102
199 177 054	102
199 177 055	102
199 177 056	102
199 177 057	102
199 177 058	102
199 177 072	108
199 177 073	108
199 177 074	108
199 177 075	108
199 177 076	108
199 177 077	108
199 177 078	108
199 177 092	103
199 177 093	103
199 177 094	103
199 177 095	103
199 177 096	103
199 177 097	103
199 177 098	103
199 177 112	109
199 177 113	109
199 177 114	109
199 177 115	109
199 177 116	109
199 177 117	109
199 177 118	109
199 177 132	107
199 177 133	107
199 177 134	107
199 177 135	107
199 177 136	107
199 177 137	107
199 177 138	107
199 177 152	113
199 177 153	113
199 177 154	113
199 177 155	113
199 177 156	113
199 177 157	113
199 177 158	113
199 177 172	105
199 177 173	105
199 177 174	105
199 177 175	105
199 177 176	105
199 177 177	105
199 177 178	105
199 177 192	111
199 177 193	111
199 177 194	111
199 177 195	111
199 177 196	111
199 177 197	111
199 177 198	111
199 177 212	106
199 177 213	106

Code	Page
199 177 214	106
199 177 215	106
199 177 216	106
199 177 217	106
199 177 218	106
199 177 232	112
199 177 233	112
199 177 234	112
199 177 235	112
199 177 236	112
199 177 237	112
199 177 238	112
199 232 003	117
199 232 004	117
199 232 005	117
199 232 006	117
199 232 007	117
199 232 008	117
199 232 012	115
199 232 013	115
199 232 014	115
199 232 015	115
199 232 016	115
199 232 017	115
199 232 018	115
199 232 023	121
199 232 024	121
199 232 025	121
199 232 026	121
199 232 027	121
199 232 028	121
199 232 032	116
199 232 033	116
199 232 034	116
199 232 035	116
199 232 036	116
199 232 037	116
199 232 038	116
199 232 043	125
199 232 044	125
199 232 045	125
199 232 046	125
199 232 047	125
199 232 048	125
199 232 052	119
199 232 053	119
199 232 054	119
199 232 055	119
199 232 056	119
199 232 057	119
199 232 058	119
199 232 063	129
199 232 064	129
199 232 065	129
199 232 066	129
199 232 067	129
199 232 068	129
199 232 072	120
199 232 073	120
199 232 074	120
199 232 075	120
199 232 076	120
199 232 077	120
199 232 078	120
199 232 083	133
199 232 084	133
199 232 085	133

Index

Code	Page
199 232 086	133
199 232 087	133
199 232 088	133
199 232 092	123
199 232 093	123
199 232 094	123
199 232 095	123
199 232 096	123
199 232 097	123
199 232 098	123
199 232 103	137
199 232 104	137
199 232 105	137
199 232 106	137
199 232 107	137
199 232 108	137
199 232 112	124
199 232 113	124
199 232 114	124
199 232 115	124
199 232 116	124
199 232 117	124
199 232 118	124
199 232 132	127
199 232 133	127
199 232 134	127
199 232 135	127
199 232 136	127
199 232 137	127
199 232 138	127
199 232 152	128
199 232 153	128
199 232 154	128
199 232 155	128
199 232 156	128
199 232 157	128
199 232 158	128
199 232 172	131
199 232 173	131
199 232 174	131
199 232 175	131
199 232 176	131
199 232 177	131
199 232 178	131
199 232 192	132
199 232 193	132
199 232 194	132
199 232 195	132
199 232 196	132
199 232 197	132
199 232 198	132
199 232 212	135
199 232 213	135
199 232 214	135
199 232 215	135
199 232 216	135
199 232 217	135
199 232 218	135
199 232 232	136
199 232 233	136
199 232 234	136
199 232 235	136
199 232 236	136
199 232 237	136
199 232 238	136
199 232 713	114
199 232 714	114

Code	Page
199 232 715	114
199 232 716	114
199 232 717	114
199 232 718	114
199 232 753	118
199 232 754	118
199 232 755	118
199 232 756	118
199 232 757	118
199 232 758	118
199 232 793	122
199 232 794	122
199 232 795	122
199 232 796	122
199 232 797	122
199 232 798	122
199 232 833	126
199 232 834	126
199 232 835	126
199 232 836	126
199 232 837	126
199 232 838	126
199 232 873	130
199 232 874	130
199 232 875	130
199 232 876	130
199 232 877	130
199 232 878	130
199 232 913	134
199 232 914	134
199 232 915	134
199 232 916	134
199 232 917	134
199 232 918	134
199 240 462	188
199 240 463	188
199 240 464	188
199 240 465	188
199 240 466	188
199 240 467	188
199 240 468	188
199 240 482	189
199 240 483	189
199 240 484	189
199 240 485	189
199 240 486	189
199 240 487	189
199 240 488	189
199 240 502	190
199 240 503	190
199 240 504	190
199 240 505	190
199 240 506	190
199 240 507	190
199 240 508	190
199 241 462	191
199 241 463	191
199 241 464	191
199 241 465	191
199 241 466	191
199 241 467	191
199 241 468	191
199 241 482	192
199 241 483	192
199 241 484	192
199 241 485	192
199 241 486	192

Code	Page
199 241 487	192
199 241 488	192
199 241 502	193
199 241 503	193
199 241 504	193
199 241 505	193
199 241 506	193
199 241 507	193
199 241 508	193
199 242 462	194
199 242 463	194
199 242 464	194
199 242 465	194
199 242 466	194
199 242 467	194
199 242 468	194
199 242 482	195
199 242 483	195
199 242 484	195
199 242 485	195
199 242 486	195
199 242 487	195
199 242 488	195
199 242 502	196
199 242 503	196
199 242 504	196
199 242 505	196
199 242 506	196
199 242 507	196
199 242 508	196
199 277 012	140
199 277 013	140
199 277 014	140
199 277 015	140
199 277 016	140
199 277 017	140
199 277 018	140
199 277 032	146
199 277 033	146
199 277 034	146
199 277 035	146
199 277 036	146
199 277 037	146
199 277 038	146
199 277 052	138
199 277 053	138
199 277 054	138
199 277 055	138
199 277 056	138
199 277 057	138
199 277 058	138
199 277 072	144
199 277 073	144
199 277 074	144
199 277 075	144
199 277 076	144
199 277 077	144
199 277 078	144
199 277 092	139
199 277 093	139
199 277 094	139
199 277 095	139
199 277 096	139
199 277 097	139
199 277 098	139
199 277 112	145
199 277 113	145

Index

Code	Page
199 277 114	145
199 277 115	145
199 277 116	145
199 277 117	145
199 277 118	145
199 277 132	143
199 277 133	143
199 277 134	143
199 277 135	143
199 277 136	143
199 277 137	143
199 277 138	143
199 277 152	149
199 277 153	149
199 277 154	149
199 277 155	149
199 277 156	149
199 277 157	149
199 277 158	149
199 277 172	141
199 277 173	141
199 277 174	141
199 277 175	141
199 277 176	141
199 277 177	141
199 277 178	141
199 277 192	147
199 277 193	147
199 277 194	147
199 277 195	147
199 277 196	147
199 277 197	147
199 277 198	147
199 277 212	142
199 277 213	142
199 277 214	142
199 277 215	142
199 277 216	142
199 277 217	142
199 277 218	142
199 277 232	148
199 277 233	148
199 277 234	148
199 277 235	148
199 277 236	148
199 277 237	148
199 277 238	148
700 245 481	23
700 245 482	23
700 245 483	23
700 245 484	23
700 245 485	23
700 245 486	23
724 600 655	21
724 600 656	21
724 600 657	21
724 600 658	21
724 600 659	21
724 600 660	21
724 600 661	21
724 600 705	21
724 600 706	21
724 600 707	21
724 600 708	21
724 600 709	21
724 600 710	21
724 600 711	21

Code	Page
724 605 505	21
724 605 506	21
724 605 507	21
724 605 508	21
724 605 509	21
724 605 510	21
724 605 511	21
724 690 105	22
724 690 106	22
724 690 107	22
724 690 108	22
724 690 109	22
724 690 110	22
724 690 111	22
727 700 206	28
727 700 207	28
727 700 208	28
727 700 209	28
727 700 210	28
727 700 211	28
727 700 212	28
727 700 313	28
727 700 314	28
727 700 315	28
727 700 316	28
727 700 317	28
727 700 318	28
727 700 319	28
727 700 320	28
727 700 321	28
727 700 322	28
727 700 323	28
727 700 324	28
727 700 325	28
727 700 406	28
727 700 407	28
727 700 408	28
727 700 409	28
727 700 410	28
727 700 411	28
727 700 412	28
727 700 513	28
727 700 514	28
727 700 515	28
727 700 516	28
727 700 517	28
727 700 518	28
727 700 519	28
727 700 520	28
727 700 521	28
727 700 522	28
727 700 523	28
727 701 206	29
727 701 207	29
727 701 208	29
727 701 209	29
727 701 210	29
727 701 211	29
727 701 212	29
727 701 313	29
727 701 314	29
727 701 317	29
727 701 319	29
727 701 320	29
727 701 406	29
727 701 407	29
727 701 408	29

Code	Page
727 701 409	29
727 701 410	29
727 701 411	29
727 701 412	29
727 701 513	29
727 701 514	29
727 701 521	29
727 701 522	29
727 701 523	29
735 018 513	13
735 018 514	13
735 018 515	13
735 018 516	13
735 018 517	13
735 018 519	13
735 018 520	13
735 018 538	212
735 018 539	212
735 018 540	212
735 018 541	212
735 018 542	212
735 018 544	212
735 018 545	212
735 018 546	212
735 018 547	212
735 018 548	212
735 018 706	13
735 018 707	13
735 018 708	13
735 018 709	13
735 018 710	13
735 018 711	13
735 018 712	13
735 018 713	13
735 018 714	13
735 018 716	13
735 018 717	13
735 018 719	13
735 018 720	13
735 018 731	212
735 018 732	212
735 018 733	212
735 018 734	212
735 018 735	212
735 018 736	212
735 018 737	212
735 018 738	212
735 018 739	212
735 018 741	212
735 018 742	212
735 018 744	212
735 018 745	212
735 100 105	32
735 100 106	32
735 100 107	32
735 100 108	32
735 100 109	32
735 100 110	32
735 100 111	32
735 108 606	13
735 108 607	13
735 108 608	13
735 108 609	13
735 108 610	13
735 108 611	13
735 108 631	213
735 108 632	213

Index

Code	Page
735 108 633	213
735 108 634	213
735 108 635	213
735 108 636	213
735 150 105	32
735 150 106	32
735 150 107	32
735 150 108	32
735 150 109	32
735 150 110	32
735 150 111	32
735 158 513	14
735 158 514	14
735 158 515	14
735 158 516	14
735 158 517	14
735 158 519	14
735 158 520	14
735 158 538	214
735 158 539	214
735 158 540	214
735 158 541	214
735 158 542	214
735 158 544	214
735 158 545	214
735 158 606	14
735 158 607	14
735 158 608	14
735 158 609	14
735 158 610	14
735 158 611	14
735 158 612	14
735 158 613	14
735 158 614	14
735 158 616	14
735 158 617	14
735 158 619	14
735 158 620	14
735 158 631	213
735 158 632	213
735 158 633	213
735 158 634	213
735 158 635	213
735 158 636	213
735 158 637	213
735 158 638	213
735 158 639	213
735 158 641	213
735 158 642	213
735 158 644	213
735 158 645	213
735 200 105	32
735 200 106	32
735 200 107	32
735 200 108	32
735 200 109	32
735 200 110	32
735 200 111	32
735 208 513	15
735 208 514	15
735 208 515	15
735 208 516	15
735 208 517	15
735 208 519	15
735 208 520	15
735 208 538	215
735 208 539	215

Code	Page
735 208 540	215
735 208 541	215
735 208 542	215
735 208 544	215
735 208 545	215
735 208 546	215
735 208 547	215
735 208 548	215
735 208 561	16
735 208 562	16
735 208 569	16
735 208 570	16
735 208 586	216
735 208 587	216
735 208 594	216
735 208 595	216
735 208 606	15
735 208 607	15
735 208 608	15
735 208 609	15
735 208 610	15
735 208 611	15
735 208 612	15
735 208 613	15
735 208 614	15
735 208 616	15
735 208 617	15
735 208 619	15
735 208 620	15
735 208 631	214
735 208 632	214
735 208 633	214
735 208 634	214
735 208 635	214
735 208 636	214
735 208 637	214
735 208 638	214
735 208 639	214
735 208 641	214
735 208 642	214
735 208 644	214
735 208 645	214
735 208 661	16
735 208 662	16
735 208 669	16
735 208 670	16
735 208 686	215
735 208 687	215
735 208 694	215
735 208 695	215
735 208 956	215
735 208 957	215
735 208 958	215
735 208 959	215
735 208 961	215
735 208 962	215
735 208 963	215
735 208 964	215
735 208 965	215
735 208 967	215
735 208 968	215
735 208 969	215
735 208 970	215
735 208 971	215
735 208 972	215
735 208 974	215
735 208 975	215

Code	Page
735 208 976	215
735 208 977	215
735 208 978	215
735 208 979	215
735 208 980	215
735 208 981	215
735 510 105	35
735 510 106	35
735 510 107	35
735 510 108	35
735 510 109	35
735 510 110	35
735 510 111	35
735 518 706	221
735 518 707	221
735 518 708	221
735 518 709	221
735 518 710	221
735 518 711	221
735 528 606	20
735 528 607	20
735 528 608	20
735 528 609	20
735 528 610	20
735 528 611	20
735 528 612	20
735 528 613	20
735 528 614	20
735 528 626	221
735 528 627	221
735 528 628	221
735 528 629	221
735 528 630	221
735 528 631	221
735 528 637	221
735 528 638	221
735 528 639	221
735 550 112	286
735 550 114	286
735 550 117	286
735 550 119	286
735 550 121	286
735 550 123	286
735 550 125	286
735 550 212	286
735 550 214	286
735 550 217	286
735 550 219	286
735 550 221	286
735 550 223	286
735 550 225	286
735 550 312	286
735 550 314	286
735 550 317	286
735 550 319	286
735 550 321	286
735 550 323	286
735 550 325	286
735 550 412	287
735 550 414	287
735 550 417	287
735 550 419	287
735 550 421	287
735 550 423	287
735 550 425	287
735 550 512	287
735 550 514	287

Index

Code	Page
735 550 517	287
735 550 519	287
735 550 521	287
735 550 523	287
735 550 525	287
735 550 612	288
735 550 614	288
735 550 617	288
735 550 619	288
735 550 621	288
735 550 623	288
735 550 625	288
735 550 712	288
735 550 714	288
735 550 717	288
735 550 719	288
735 550 721	288
735 550 723	288
735 550 725	288
735 550 814	287
735 550 817	287
735 550 819	287
735 550 821	287
735 550 823	287
735 550 825	287
735 598 006	226
735 598 008	226
735 598 009	226
735 598 010	226
735 598 014	226
735 598 016	226
735 598 018	226
735 598 056	226
735 598 057	226
735 598 059	226
735 598 062	226
735 598 065	226
735 598 067	226
735 598 157	226
735 598 159	226
735 598 163	226
735 598 165	226
735 598 167	226
735 598 169	226
735 598 207	227
735 598 209	227
735 598 213	227
735 598 215	227
735 598 217	227
735 598 219	227
735 598 259	227
735 598 262	227
735 598 265	227
735 598 267	227
735 598 269	227
735 598 309	227
735 598 312	227
735 598 315	227
735 598 317	227
735 598 319	227
735 598 357	227
735 598 359	227
735 598 362	227
735 598 365	227
735 598 367	227
735 598 369	227
735 598 406	228

Code	Page
735 598 408	228
735 598 410	228
735 598 414	228
735 598 416	228
735 598 418	228
735 598 506	228
735 598 508	228
735 598 510	228
735 598 806	228
735 598 807	228
735 598 808	228
735 598 809	228
735 598 810	228
735 598 811	228
735 600 105	35
735 600 106	35
735 600 107	35
735 600 108	35
735 600 109	35
735 600 110	35
735 600 111	35
735 608 606	20
735 608 607	20
735 608 608	20
735 608 609	20
735 608 610	20
735 608 611	20
735 608 612	20
735 608 613	20
735 608 614	20
735 640 105	37
735 640 106	37
735 640 107	37
735 640 108	37
735 640 109	37
735 640 110	37
735 640 111	37
735 648 606	22
735 648 607	22
735 648 608	22
735 648 609	22
735 648 610	22
735 648 611	22
735 648 612	22
735 648 613	22
735 648 614	22
735 690 405	22
735 690 406	22
735 690 407	22
735 690 408	22
735 690 409	22
735 690 410	22
735 690 411	22
735 690 422	223
735 690 423	223
735 690 424	223
735 730 106	41
735 730 107	41
735 730 108	41
735 730 109	41
735 730 110	41
735 730 111	41
735 740 106	41
735 740 107	41
735 740 108	41
735 740 109	41
735 740 110	41

Code	Page
735 740 111	41
735 790 206	42
735 790 207	42
735 790 208	42
735 790 209	42
735 790 210	42
735 790 211	42
735 790 257	42
735 790 258	42
735 790 259	42
735 790 260	42
735 798 565	27
735 798 590	230
735 798 596	230
735 798 597	230
735 798 598	230
735 798 806	26
735 798 807	26
735 798 808	26
735 798 809	26
735 798 810	26
735 798 811	26
735 798 812	26
735 798 813	26
735 798 814	26
735 798 816	26
735 798 817	26
735 798 819	26
735 798 820	26
735 798 831	229
735 798 832	229
735 798 833	229
735 798 834	229
735 798 835	229
735 798 836	229
735 798 837	229
735 798 838	229
735 798 839	229
735 798 841	229
735 798 842	229
735 798 844	229
735 798 845	229
735 798 857	26
735 798 858	26
735 798 859	26
735 798 860	26
735 798 861	26
735 798 863	27
735 798 864	27
735 798 866	27
735 798 867	27
735 798 869	27
735 798 870	27
735 798 882	229
735 798 883	229
735 798 884	229
735 798 888	230
735 798 889	230
735 798 891	230
735 798 892	230
735 798 894	230
735 798 895	230
735 810 106	42
735 810 107	42
735 810 108	42
735 810 109	42
735 810 110	42

Index

Code	Page
735 810 111	42
735 908 500	220
735 908 501	220
735 908 502	220
735 908 503	220
735 908 504	220
735 908 505	220
735 908 506	220
735 908 507	220
735 908 508	220
735 908 511	220
735 908 513	220
735 908 515	220
735 908 521	220
735 908 526	220
735 908 531	220
735 908 532	220
735 908 533	220
735 908 551	19
735 908 553	19
735 908 555	19
735 908 561	19
735 908 566	19
735 908 580	19
735 908 584	19
735 908 585	19
735 908 588	19
735 908 590	19
735 908 592	19
735 908 595	19
735 908 596	19
735 908 597	19
735 908 600	220
735 908 601	220
735 908 602	220
735 908 603	220
735 908 604	220
735 908 605	220
735 908 606	220
735 908 607	220
735 908 608	220
735 908 609	220
735 908 610	220
735 908 611	220
735 908 612	220
735 908 613	220
735 908 614	220
735 908 615	220
735 908 616	220
735 908 617	220
735 908 618	220
735 908 619	220
735 908 621	220
735 908 622	220
735 908 623	220
735 908 624	220
735 908 625	220
735 908 626	220
735 908 627	220
735 908 637	19
735 908 641	19
735 908 642	19
735 908 646	19
735 908 647	19
735 908 648	19
735 908 652	19
735 908 653	19

Code	Page
735 908 654	19
735 908 658	19
735 908 659	19
735 908 660	19
735 908 664	19
735 908 665	19
735 908 666	19
735 908 670	19
735 908 671	19
735 908 676	19
735 908 677	19
735 908 678	19
735 908 685	19
735 908 688	19
735 908 690	19
735 908 692	19
735 908 695	19
735 908 696	19
735 908 697	19
735 910 105	34
735 910 106	34
735 910 107	34
735 910 108	34
735 910 109	34
735 910 110	34
735 910 111	34
735 910 206	39
735 910 207	39
735 910 208	39
735 910 209	39
735 910 210	39
735 910 211	39
735 910 265	24
735 910 266	24
735 910 267	24
735 910 268	24
735 910 269	24
735 910 270	24
735 910 271	24
735 910 334	33
735 910 337	33
735 910 341	33
735 910 342	33
735 910 346	33
735 910 347	33
735 910 348	33
735 910 352	33
735 910 353	33
735 910 354	33
735 910 355	33
735 910 358	33
735 910 359	33
735 910 360	33
735 910 361	33
735 910 362	33
735 910 505	39
735 910 506	39
735 910 507	39
735 910 508	39
735 910 509	39
735 910 510	39
735 910 511	39
735 910 555	24
735 910 556	24
735 910 557	24
735 910 558	24
735 910 559	24

Code	Page
735 910 560	24
735 910 561	24
735 910 706	224
735 910 707	224
735 910 708	224
735 910 709	224
735 910 710	224
735 910 711	224
735 910 736	224
735 910 737	224
735 910 738	224
735 910 739	224
735 910 740	224
735 910 741	224
735 914 205	39
735 914 206	39
735 914 207	39
735 914 208	39
735 914 209	39
735 914 210	39
735 914 211	39
735 914 265	25
735 914 266	25
735 914 267	25
735 914 268	25
735 914 269	25
735 914 270	25
735 914 271	25
735 914 306	224
735 914 307	224
735 914 308	224
735 914 309	224
735 914 310	224
735 914 311	224
735 914 406	225
735 914 407	225
735 914 408	225
735 914 409	225
735 914 410	225
735 914 411	225
735 914 505	40
735 914 506	40
735 914 507	40
735 914 508	40
735 914 509	40
735 914 510	40
735 914 511	40
735 914 555	24
735 914 556	24
735 914 557	24
735 914 558	24
735 914 559	24
735 914 560	24
735 914 561	24
735 918 565	17
735 918 566	17
735 918 567	17
735 918 569	17
735 918 570	17
735 918 611	17
735 918 612	17
735 918 613	17
735 918 614	17
735 918 615	17
735 918 616	17
735 918 617	17
735 918 619	17

Index

Code	Page
735 918 620	17
735 918 656	216
735 918 657	216
735 918 658	216
735 918 659	216
735 918 660	216
735 918 661	216
735 918 662	216
735 918 663	216
735 918 664	216
735 918 811	17
735 918 812	17
735 918 813	17
735 918 814	17
735 938 737	219
735 938 741	219
735 938 742	219
735 938 746	219
735 938 747	219
735 938 748	219
735 938 752	219
735 938 753	219
735 938 758	219
735 938 759	219
735 938 760	219
735 960 105	34
735 960 106	34
735 960 107	34
735 960 108	34
735 960 109	34
735 960 110	34
735 960 111	34
735 960 405	40
735 960 406	40
735 960 407	40
735 960 408	40
735 960 409	40
735 960 410	40
735 960 411	40
735 968 606	25
735 968 607	25
735 968 608	25
735 968 609	25
735 968 610	25
735 968 611	25
735 968 731	225
735 968 732	225
735 968 733	225
735 968 734	225
735 968 735	225
735 968 736	225
735 991 430	225
735 991 431	225
735 991 432	225
735 991 433	225
735 991 435	225
735 991 436	225
735 991 437	225
735 991 438	225
735 991 439	225
735 991 442	225
735 991 443	225
735 991 444	225
735 991 651	219
735 991 652	219
735 991 653	219
735 991 654	219

Code	Page
735 991 655	219
735 991 656	219
735 991 657	219
735 991 658	219
735 991 659	219
735 991 661	219
735 991 662	219
735 991 663	219
743 400 806	228
743 400 807	228
743 400 808	228
743 400 809	228
743 400 810	228
743 400 811	228
748 410 000	46
748 410 001	46
748 410 002	46
748 410 003	46
748 410 004	23
748 410 005	23
748 410 006	23
748 410 007	23
748 410 008	23
748 410 009	23
748 410 010	23
748 410 011	23
748 410 012	46
748 410 013	46
748 410 014	23
748 410 015	23
748 410 016	23
748 440 100	31
748 440 101	31
748 440 102	31
748 440 103	31
748 440 104	31
748 440 105	31
748 440 106	31
748 440 107	31
748 440 108	31
748 440 109	31
748 440 110	31
748 440 111	31
748 440 112	31
748 440 114	31
748 440 115	31
748 440 116	31
748 440 117	31
748 440 118	31
748 440 119	31
748 440 120	31
749 400 112	288
749 400 114	288
749 400 117	288
749 400 119	288
749 400 121	288
749 400 123	288
749 400 125	288
749 410 000	46
749 410 001	46
749 410 002	46
749 410 003	46
749 410 004	23
749 410 005	23
749 410 006	23
749 410 007	23
749 410 008	23

Code	Page
749 410 009	23
749 410 010	23
749 410 011	23
749 410 012	46
749 410 013	46
749 410 014	23
749 410 015	23
749 410 016	23
749 411 005	223
749 411 006	223
749 411 014	223
749 411 015	223
749 411 016	223
749 411 054	223
749 411 062	223
749 411 120	223
749 411 172	223
749 440 100	31
749 440 101	31
749 440 102	31
749 440 103	31
749 440 104	31
749 440 105	31
749 440 106	31
749 440 107	31
749 440 108	31
749 440 109	31
749 440 110	31
749 440 111	31
749 440 112	31
749 440 114	31
749 440 115	31
749 440 116	31
749 440 117	31
749 440 118	31
749 440 119	31
749 440 120	31
790 109 001	308
790 109 002	308
790 109 003	308
790 121 001	303
790 121 002	302
790 121 047	304
790 121 048	304
790 121 049	304
790 121 471	304
790 121 472	304
790 121 473	304
790 122 041	304
790 122 042	304
790 122 043	304
790 122 044	304
790 122 045	304
790 122 046	304
790 122 085	308
790 122 091	304
790 122 092	304
790 122 093	304
790 122 094	304
790 122 095	304
790 122 096	304
790 122 104	303
790 122 106	303
790 122 978	303
790 131 005	295
790 131 030	299
790 131 031	299

Index

Code	Page	Code	Page
790 131 032	299	799 300 290	306
790 131 033	299	799 300 300	306
790 131 034	299	799 300 310	306
790 131 035	299	799 300 320	306
790 131 038	298	799 300 330	306
790 131 039	298	799 300 340	306
790 131 040	298		
790 131 041	298		
790 131 042	298		
790 131 043	298		
790 131 045	298		
790 131 046	300		
790 131 047	300		
790 131 048	300		
790 131 049	300		
790 131 051	300		
790 131 471	298		
790 131 472	298		
790 131 473	298		
790 133 009	296		
790 133 026	298		
790 133 027	298		
790 133 028	298		
790 133 029	298		
790 133 030	298		
790 133 031	298		
790 133 032	298		
790 133 033	298		
790 133 034	298		
790 133 036	299		
790 133 037	299		
790 133 038	299		
790 133 039	299		
790 133 040	299		
790 133 041	299		
790 133 042	299		
790 133 043	299		
790 133 046	299		
790 133 047	300		
790 133 061	299		
790 133 062	299		
790 309 001	306		
790 309 002	306		
790 310 001	305		
790 310 003	305		
790 310 011	307		
790 310 012	307		
790 310 013	307		
790 310 014	307		
790 310 015	307		
790 310 016	307		
790 310 017	307		
790 310 018	307		
790 310 099	307		
799 298 023	308		
799 300 156	306		
799 300 157	306		
799 300 158	306		
799 300 159	306		
799 300 160	306		
799 300 161	306		
799 300 162	306		
799 300 163	306		
799 300 164	306		
799 300 260	306		
799 300 270	306		
799 300 280	306		

General Condition of Supply of Georg Fischer Piping Systems Limited, Schaffhausen

1 General

- 1.1 These General Conditions shall apply to all Products supplied by Georg Fischer to the Purchaser. They shall also apply to all future business even when no express reference is made to them.
- 1.2 Any deviating or supplementary conditions especially Purchaser's general conditions of purchase and verbal agreements shall only be applicable if accepted in writing by Georg Fischer.
- 1.3 The written form shall be deemed to be fulfilled by all forms of transmission, evidenced in the form of text, such as telefax, e-mail, etc.

2 Tenders

- 2.1 Tenders shall only be binding if they contain a specifically stated period for acceptance.

3 Scope of Delivery

- 3.1 Georg Fischer's product range is subject to change.
- 3.2 The confirmation of order shall govern the scope and execution of the contract.

4 Data and Documents

- 4.1 Technical documents such as drawings, descriptions, illustrations and data on dimensions, performance and weight as well as the reference to standards are for information purposes only. They are not warranted characteristics and are subject to change.
- 4.2 All technical documents shall remain the exclusive property of Georg Fischer and may only be used for the agreed purposes or as Georg Fischer may consent.

5 Confidentiality, Protection of Personal Data

- 5.1 Each party shall keep in strict confidence all commercial or technical information relating to the business of the other party, of which it has gained knowledge in the course of its dealing with the other party. Such information shall neither be disclosed to third parties nor used for other purposes than those for which the information has been supplied.
- 5.2 In the context of the contractual relation with the Purchaser personal data may be processed. The Purchaser agrees to the disclosure of said data to third parties such as foreign subcontractors and suppliers etc.

6 Local Laws and Regulations, Export Controls

- 6.1 The Purchaser shall bring to the attention of Georg Fischer all local laws and regulations at the place of destination which bear connection with the execution of the contract and the adherence to relevant safety regulations and approval procedures.
- 6.2 In case of re-exports, Purchaser shall be responsible for compliance with pertinent export control regulations.

7 Price

- 7.1 Unless agreed otherwise, the prices shall be deemed quoted net ex works (according to Incoterms of the ICC, latest version) including standard packing. All supplementary costs such as the cost of carriage, insurance, export-, transit- and import duties etc. shall be borne by the Purchaser. The Purchaser shall also bear the costs of all taxes, fees, duties etc. connected with the contract.
- 7.2 If the costs of packing, carriage, insurance, fees and other supplementary costs are included in the tender price or contract price or are referred to specifically in the tender or confirmation of order, Georg Fischer reserve the right to revise their prices accordingly should any change occur in the relevant tariffs.

8 Terms of Payment

- 8.1 The Purchaser shall make payment in the manner agreed by the parties without any deductions such as discounts, costs, taxes or dues.
- 8.2 The Purchaser may only withhold or off-set payments due against counter claims which are either expressly acknowledged by Georg Fischer or finally awarded to the Purchaser. In particular, payment shall still be made when unessential items are still out-standing provided that the Products already delivered are not rendered unusable as a result.

9 Retention of Title

- 9.1 The Products shall remain the property of Georg Fischer until the Purchaser shall have settled all claims, present and future, which Georg Fischer may have against him.
- 9.2 Should the Purchaser resell Products to which title is reserved, in the ordinary course of business, he shall hereby be deemed to have tacitly assigned to Georg Fischer the proceeds deriving from their sale together with all collateral rights, securities and reservations of title until all claims held by Georg Fischer shall have been settled. Until revoked by Georg Fischer, this assignment shall not preclude Purchaser's right to collect the assigned receivables.
- 9.3 To the extent the value of the Products to which title is reserved together with collateral securities exceeds Georg Fischer's claims against the Purchaser by more than 20%, Georg Fischer shall re-assign the above proceeds to Purchaser at his request.

10 Delivery

- 10.1 The term of delivery shall commence as soon as the contract has been entered into, all official formalities such as import and payment permits have been obtained and all essential technical issues have been settled. The term of delivery shall be deemed duly observed when, upon its expiry, the Products are ready for despatch.
- 10.2 Delivery is subject to the following conditions, i.e. the term of delivery shall be reasonably extended:
 - a) if Georg Fischer are not supplied in time with the information necessary for the execution of the contract or if subsequent changes causing delays are made by the Purchaser.
 - b) if Georg Fischer are prevented from performing the contract by force majeure. Force majeure shall equally be deemed to be any unforeseeable event beyond Georg Fischer's control which renders Georg Fischer's performance commercially unpractical or impossible, such as delayed or defective supplies from sub contractors labour disputes, governmental orders or regulations, shortages in materials or energy, serious disturbances in Georg Fischer's works, such as the total or partial destruction of plant and equipment or the breakdown of essential facilities, serious disruptions in transport facilities, e.g. impassable roads.
Should the effect of force majeure exceed a period of six months, either party may cancel the contract forthwith.
Georg Fischer shall not be liable for any damage or loss of any kind whatsoever resulting therefrom, any suspension or cancellation being without prejudice to Georg Fischer's right to recover all sums due in respect of consignments delivered and costs incurred to date.
 - c) if the Purchaser is in delay with the fulfilment of his obligations under the contract, in particular, if he does not adhere to the agreed conditions of payment or if he has failed to timely provide the agreed securities.
- 10.3 If for reasons attributable to Georg Fischer the agreed term of delivery or a reasonable extension thereof is exceeded, Georg Fischer shall not be deemed in default until the Purchaser has granted to Georg Fischer in writing a reasonable extension thereof of not less than one month which equally is not met.
The Purchaser shall then be entitled to the remedies provided at law, it being however understood that, subject to limitations of Art. 16, damage claims shall be limited to max. 10% of the price of the delayed delivery.
- 10.4 Part shipments shall be allowed and Georg Fischer shall be entitled to invoice for such partial deliveries.
- 10.5 If the Purchaser fails to take delivery within a reasonable time of Products notified as ready for despatch, Georg Fischer shall be entitled to store the Products at the Purchaser's expense and risk and to invoice them as delivered. If Purchaser fails to effect payment, Georg Fischer shall be entitled to dispose of the Products.
- 10.6 Should Purchaser cancel an order without justification and should Georg Fischer not insist on the performance of the contract, Georg Fischer shall be entitled to liquidated damages in the amount of 10% of the contract price, Georg Fischer's right to prove and claim higher damages remaining reserved. Purchaser shall be entitled to prove, that Georg Fischer has suffered no or a considerably lower damage.

11 Packing

- 11.1 If the Products are provided with additional packing over and above the standard packing, such packing shall be charged additionally.

12 Passing of Risk

- 12.1 The risk in the Products shall pass to the Purchaser as soon as they have left Georg Fischer's works (EXWORKS, Incoterms ICC, latest version), even if delivery is made carriage-paid, under similar clauses or including installation or when carriage is organized and managed by Georg Fischer.
- 12.2 If delivery is delayed for reasons beyond Georg Fischer's control, the risk shall pass to the Purchaser when he is notified that the Products are ready for despatch.

13 Carriage and Insurance

- 13.1 Unless agreed otherwise, the Purchaser shall bear the cost of carriage.
- 13.2 The Purchaser shall be responsible for transport insurance against damage of whatever kind. Even when such insurance is arranged by Georg Fischer it shall be deemed taken out by the order of and for the account of the Purchaser and at his risk.
- 13.3 Special requests regarding carriage and insurance shall be communicated to Georg Fischer in due time. Otherwise carriage shall be arranged by Georg Fischer at their discretion, but without responsibility, by the quickest and cheapest method possible.
In case of carriage-paid delivery transport arrangements shall be made by Georg Fischer. If the Purchaser specifies particular requirements, any extra costs involved shall be borne by him.
- 13.4 In the event of damage or loss of the Products during carriage the Purchaser shall mark the delivery documents accordingly and immediately have the damage ascertained by the carrier. Not readily ascertainable damages sustained during carriage shall be notified to the carrier within six days after receipt of the Products.

14 Inspection, Notification of Defects and Damages

- 14.1 The Products will be subject to normal inspection by Georg Fischer during manufacture. Additional tests required by the Purchaser shall be agreed upon in writing and shall be charged to the Purchaser.
- 14.2 It shall be a condition of Georg Fischer's obligation under the warranties stated hereinafter that Georg Fischer be notified in writing by the Purchaser of any purported defect immediately upon discovery. Notice concerning weight, numbers or apparent defects is to be given latest within 30 days from receipt of the Products, notice of other defects immediately latest within 7 working days after discovery, in any event within the agreed warranty period.
- 14.3 Purchaser shall not dispose of allegedly defective Products until all warranty and/or damage claims are finally settled. At its request, defective Products are to be placed at Georg Fischer's disposal.
- 14.4 At its request, Georg Fischer shall be given the opportunity to inspect the defect and/or damage, prior to commencement of remedial work, either itself or by third party experts.

15 Warranty

- 15.1 At the written request of the Purchaser, Georg Fischer undertake to repair or replace at their discretion, as quickly as possible and free of charge all Products supplied which demonstrably suffer from faulty design, materials or workman-ship or from faulty operating or installation instructions.
In order to protect employees from toxic or radioactive substances which may have been transported through defective parts returned to Georg Fischer's sales organisation, said parts must be accompanied by a Material Safety Disclosure Form. The form may be obtained from Georg Fischer's local sales company or via www.piping.georgfischer.com.
Replaced parts shall become property of Georg Fischer.
- 15.2 For Products which are manufactured to specifications, drawings or patterns supplied by the Purchaser, Georg Fischer's warranty shall be restricted to proper materials and workmanship.
- 15.3 The Purchaser shall be entitled to cancel the contract or to demand a reduction in the contract price if also a second attempt to repair or replace the Products has failed.
- 15.4 For Products or essential components manufactured by a third party and supplied by Georg Fischer under this contract, Georg Fischer's warranty is limited to the warranty provided by said third party.
- 15.5 This warranty shall not apply to damage resulting from normal wear and tear, improper storage and maintenance, failure to observe the operating instructions, overstressing or overloading, unsuitable operating media, unsuitable construction work or unsuitable building ground, improper repairs or alterations by the Purchaser or third parties, the use of other than original spare parts and other reasons beyond Georg Fischer's control.
- 15.6 No action or claim may be brought by the Purchaser on account of any alleged breach of warranty or any other obligation of Georg Fischer after the expiration of twelve (12) months from receipt of the Products by the end user or at the latest within eighteen (18) months of the Products being despatched by Georg Fischer.
- 15.7 In case of Products for use in domestic installations or in utilities
 - Georg Fischer will assume the costs of dismantling the defective Product and restoring the damaged object as well as, in case of negligence, all other direct damages caused by the defective Product (damage to property and injury to or death of persons) up to CHF 1 000 000 per occurrence.
 - the statute of limitations for warranty or damage claims - contrary to Section 15.6 - will be 5 years from the date of installation.

16 Limitation of Liability

- 16.1 All cases of breach of contract and the relevant consequences as well as all rights and claims on the part of the customer, irrespective of what ground they are based, are exhaustively covered by these general conditions of supply. In particular, any claims not expressly mentioned for damages, reduction of price, termination of or withdrawal from the contract are excluded. In no case whatsoever shall the customer be entitled to claim damages other than compensation for costs of remedying defects in the supplies. This in particular refers, but shall not be limited, to loss of production, loss of use, loss of orders, loss of profit and other direct or indirect or consequential damage. This exclusion of liability, however, does not apply to unlawful intent or gross negligence on the part of Georg Fischer and in case of strict liability under applicable product liability statutes, but does apply to unlawful intent or gross negligence of persons employed or appointed by Georg Fischer to perform any of its obligations.

17 Severability

- 17.1 Should any term or clause of these General Conditions in whole or in part be found to be unenforceable or void, all other provisions shall remain in full force and effect and the unenforceable or void provision shall be replaced by a valid provision, which comes closest to the original intention of the unenforceable or invalid provision.

18 Place of Performance and Jurisdiction

- 18.1 Place of performance for the Products shall be the Georg Fischer works from which the Products are despatched.
- 18.2 Any civil action based upon any alleged breach of this contract shall be filed and prosecuted exclusively in the courts of Schaffhausen, Switzerland.
Georg Fischer however reserves the right to file actions in any court having jurisdiction over controversies arising out of or in connection with the present contract.
- 18.3 The contract shall be governed by Swiss law without regard to conflict of law provisions that would require the application of another law.

GF Piping Systems → Worldwide

Our sales companies and representatives ensure local customer support in over 100 countries.

www.piping.georgfischer.com



The technical data are not binding and not expressly warranted characteristics of the goods. They are subject to change. Our General Conditions of Sale apply.

Export

Georg Fischer
Piping Systems (Switzerland) Ltd.
8201 Schaffhausen
Phone +41 (0)52 631 30 26
Fax +41 (0)52 631 28 93
export.ps@georgfischer.com
www.piping.georgfischer.ch

Australia

George Fischer Pty Ltd
Unit 1, 100 Belmore Road
Riverwood NSW 2210 Australia
Phone +61(0)2/9502 8000
australia.ps@georgfischer.com
www.georgfischer.com.au

Austria

Georg Fischer
Rohrleitungssysteme GmbH
3130 Herzogenburg
Phone +43(0)2782/856 43-0
austria.ps@georgfischer.com
www.georgfischer.at

Belgium/Luxembourg

Georg Fischer NV/SA
1070 Bruxelles/Brüssel
Phone +32(0)2/556 40 20
be.ps@georgfischer.com
www.georgfischer.be

Brazil

George Fischer Ltda
04795-100 São Paulo
Phone +55(0)11/5687 1311
br.ps@georgfischer.com

China

Georg Fischer
Piping Systems Ltd Shanghai
Pudong, Shanghai 201319
Phone +86(0)21/58 13 33 33
china.ps@georgfischer.com
www.cn.piping.georgfischer.com

Denmark/Iceland

Georg Fischer A/S
2630 Taastrup
Phone +45 (0)70 22 19 75
info.dk.ps@georgfischer.com
www.georgfischer.dk

France

George Fischer S.A.S.
Bâtiment Le Rabelais Paris Nord 2
22 Avenue des Nations
BP 88026 Villepinte
95932 Roissy Charles de Gaulle Cedex
Phone +33(0)1/41 84 68 84
fr.ps@georgfischer.com
www.georgfischer.fr

Germany

Georg Fischer GmbH
73095 Albershausen
Phone +49(0)7161/302-0
info.de.ps@georgfischer.com
www.vgd.georgfischer.de

India

George Fischer Piping Systems Ltd
400 093 Mumbai
Phone +91 224007 201
in.ps@georgfischer.com

Italy

Georg Fischer S.p.A.
20063 Cernusco S/N (MI)
Phone +3902/921 861
it.ps@georgfischer.com
www.georgfischer.it

Japan

Georg Fischer Ltd
556-0011 Osaka,
Phone +81(0)6/6635 2691
jp.ps@georgfischer.com
www.georgfischer.jp

Malaysia

Georg Fischer (M) Sdn. Bhd.
47500 Subang Jaya
Phone +60 (0)3-8024 7879
conne.kong@georgfischer.com.my

Middle East

George Fischer Piping Systems
Dubai, United Arab Emirates
Phone +971 4 289 41 20
gfdubai@emirates.net.ae
www.piping.georgfischer.com

Netherlands

Georg Fischer N.V.
8161 PA Epe
Phone +31(0)578/678 222
nl.ps@georgfischer.com
www.georgfischer.nl

Norway

Georg Fischer AS
1351 Rud
Phone +47(0)67 18 29 00
no.ps@georgfischer.com
www.georgfischer.no

Poland

Georg Fischer Sp. z o.o.
02-226 Warszawa
Phone +48(0)22/313 10 50
poland.ps@georgfischer.com
www.georgfischer.pl

Romania

Georg Fischer Piping Systems Ltd.
70000 Bucharest - Sector 1
Phone +40(0)21 230 53 80
ro.ps@georgfischer.com

Russia

Georg Fischer Piping Systems
Representative Office Moscow
125047 Moscow
Phone +7(0)495 258 60 80
ru.ps@georgfischer.com

Singapore

George Fischer Pte Ltd
528 872 Singapore
Phone +65(0)67 47 06 11
sgp.ps@georgfischer.com
www.georgfischer.com.sg

Spain/Portugal

Georg Fischer S.A.
280046 Madrid
Phone +34(0)91/781 98 90
es.ps@georgfischer.com
www.georgfischer.es

Sweden/Finland

Georg Fischer AB
12523 Älvsjö-Stockholm
Phone +46(0)8 506 775 00
info.se.ps@georgfischer.com
www.georgfischer.se

Switzerland

Georg Fischer
Rohrleitungssysteme (Schweiz) AG
8201 Schaffhausen
Phone +41(0)52 631 30 26
ch.ps@georgfischer.com
www.piping.georgfischer.ch

Taiwan

Georg Fischer Ltd.
2F, No. 88, Hsing Te Road
San Chung City
Taipei Hsien, Taiwan (R.O.C.)
Phone +886 2 8512 2822
Fax +886 2 8512 2823

United Kingdom/Ireland

George Fischer Sales Limited
Coventry, CV2 2ST
Phone +44(0)2476 535 535
uk.ps@georgfischer.com
www.georgfischer.co.uk

USA/Canada/Latin America/Caribbean

George Fischer Inc.
Tustin, CA 92780-7258
Phone +1(714) 731 88 00
Toll Free 800/854 40 90
us.ps@georgfischer.com
www.us.piping.georgfischer.com