

Standardized Chemical Pumps

to EN 22 858/ISO 2858/ISO 5199
sealless, with magnetic drive

Fields of Application

For handling aggressive, toxic, explosive, valuable, inflammable, malodorous or hazardous liquids in the chemical, petrochemical and general industries.

Any CPK pump with shaft seal can easily and economically be converted to a sealless design with a back pull-out unit. casing, impeller, mechanical coupling, coupling guard, baseplate and motor are reusable.

Design

Horizontal, radially split volute casing pumps in back pull-out design to ISO 2858/EN 22858/ISO 5199, fitted with a radial impeller, single-entry, single-stage, sealless, with magnetic drive.

Designation

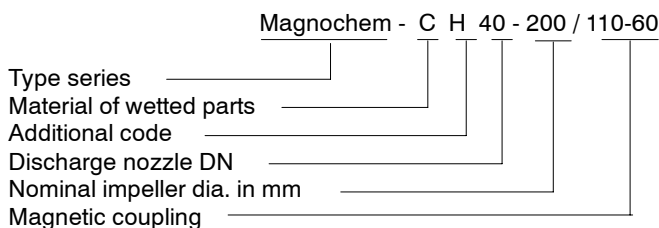

Additional codes:
H = Heatable design

Operating Data

Capacities	Q	up to 1400 m ³ /h (388 l/s)
Heads	H	up to 225 m
DN discharge nozzle	DN	from 25 to 250
Motor rating	P	up to 160 kW



Selection Charts

n = 1450/1750 1/min

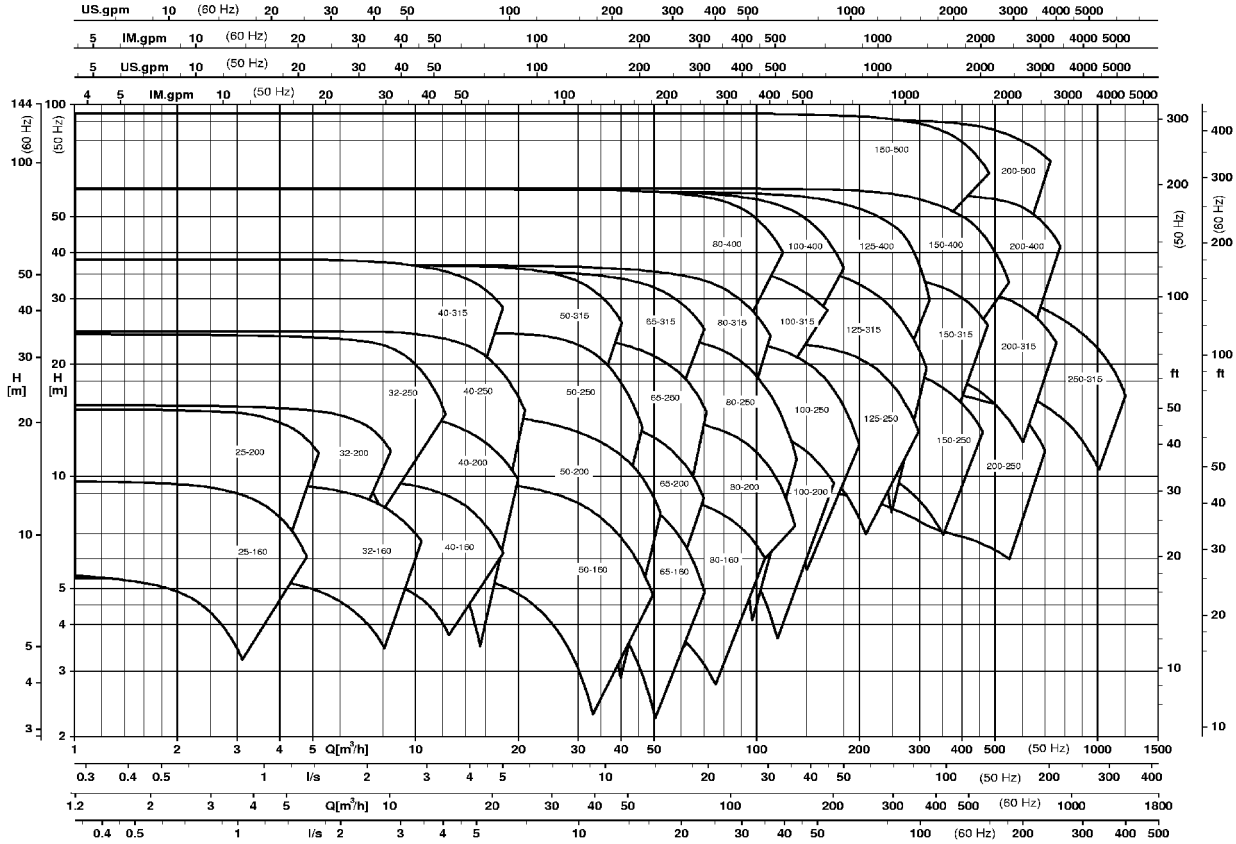

n = 2900/3500 1/min

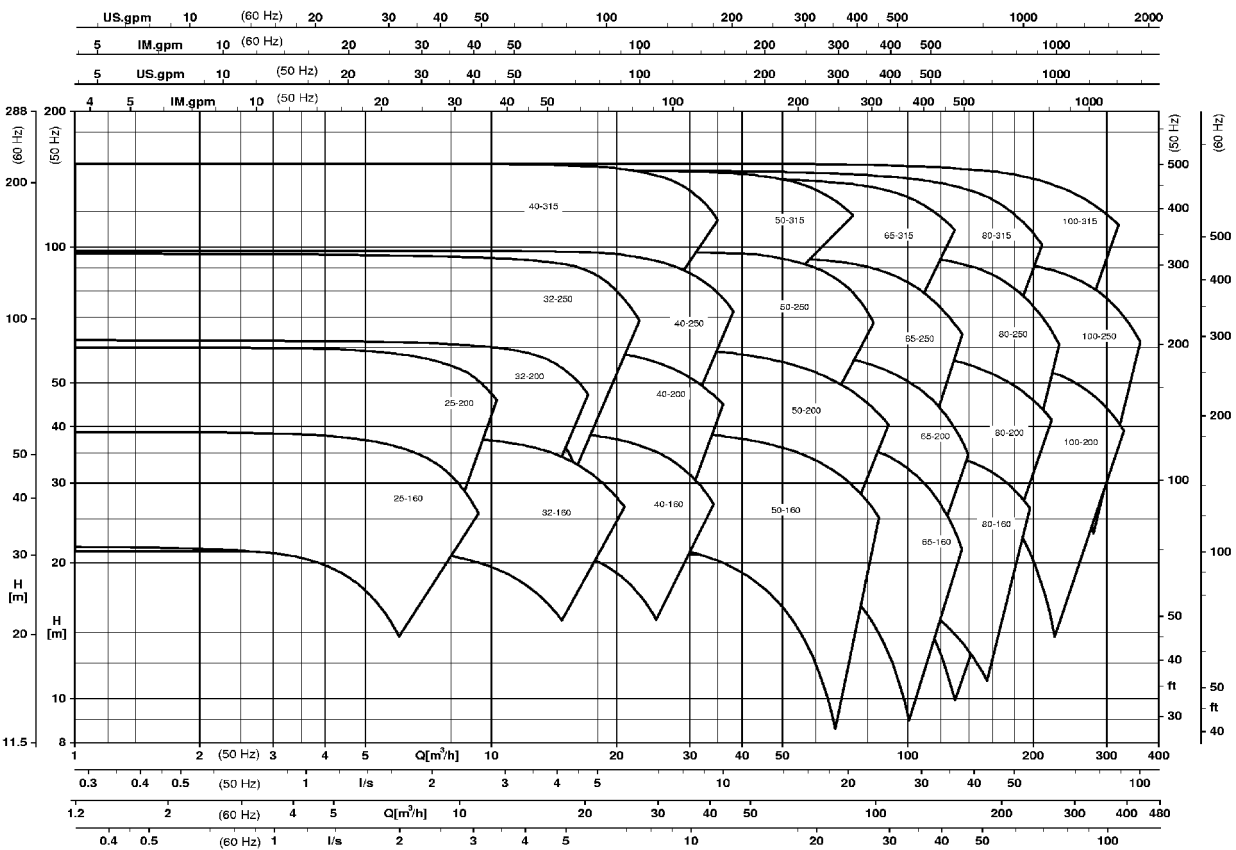

Material Variants

Part No.	Description	S2/S4	E	E4	C1/C1V ⁴⁾	C3.1/C3.2
102	Volute casing	JS1025 ⁶⁾	GP240GH+N	1.7706	1.4408	Noridur 1.4593
161	Casing cover	P250GH ³⁾	P250GH ³⁾	P250GH ³⁾	1.4571/1.4408	1.4462
183	Support foot	S235JRG2	S235JRG2	S235JRG2	S235JRG2	S235JRG2
210.01	Shaft (Rolling element bearings)	C45+N	C45+N	C45+N	C45+N	C45+N
210.03	Shaft (Plain bearings)	1.4462	1.4462	1.4462	1.4462	1.4462
230	Impeller	JL1040 ¹⁾⁷⁾	JL1040 ¹⁾⁷⁾	JL1040 ¹⁾⁷⁾	1.4408	Noridur 1.4593
310	Plain bearing with spring	Sicadur ⁹⁾	Sicadur ⁹⁾	Sicadur ⁹⁾	Sicadur ⁹⁾	Sicadur ⁹⁾
330	Bearing bracket	1.4571	1.4571	1.4571	1.4571	1.4462
344	Bearing bracket lantern	JL1040 ⁷⁾	JL1040 ⁷⁾	JL1040 ⁷⁾	JL1040 ⁷⁾	JL1040 ⁷⁾
817	Bearing bracket lantern	JL1040 ²⁾⁷⁾	JL1040 ²⁾⁷⁾	JL1040 ²⁾⁷⁾	JL1040 ²⁾⁷⁾	JL1040 ²⁾⁷⁾
817	Flange/containment shroud/containment shroud bottom	1.4571 ^{8)/} 2.4610/ 1.4462	1.4571 ^{8)/} 2.4610/ 1.4462	1.4571 ^{8)/} 2.4610/ 1.4462	1.4571/ 2.4610/ 1.4462	1.4462/ 2.4610/ 1.4462
818.01	Inner rotor	1.4571/1.4539	1.4571/1.4539	1.4571/1.4539	1.4571/1.4539	1.4462/1.4539
818.02	Outer rotor	St	St	St	St	St
920.95	Impeller nut	A4	A4	A4	A4	1.4462

1) impeller tip speed $u > 48$ m/s and/or $t < -30$ °C: 1.4408;

bearing bracket P 04/05: always JS1025 impellers

2) steel version available

3) $t < -10$ °C: 1.4571/1.4408

4) C1V = 1.4408 as per VDMA 24 276

5) Sicodur Supra coating (diamond coating of the SSiC) optional

6) to EN 1563 = GJS-400-18-LT

7) to EN 1561 = GJL-250

8) magnetic coupling 165: 1.4462

9) Sicadur = SiC⁵⁾/1.4462

Pressure and Temperature Limits

Material variant S2

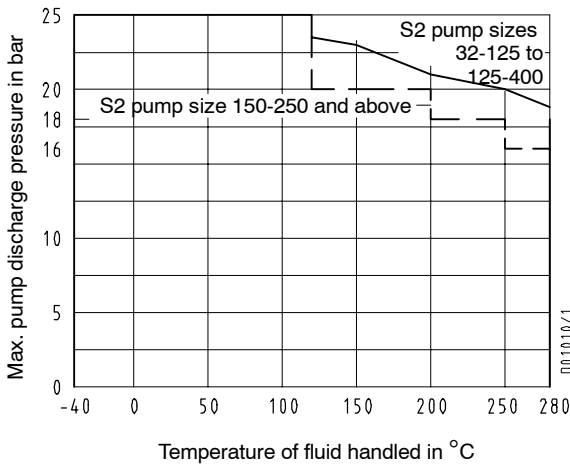

Material variants C1, C1V, C3.1/C3.2 and E

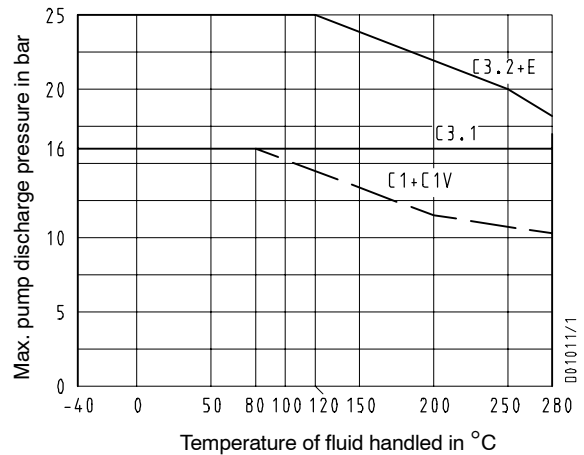

		Material variant: S4 Pump casing in JS1025 $\sigma_{0,2}$ values to EN 1563					Material variant: E4 Pump casing in 1.7706 $\sigma_{0,2}$ values to EN 10213-2			
Bearing bracket	Size	P_{max} at 50 °C	P_{max} at 120 °C	P_{max} at 150 °C	P_{max} at 200 °C	P_{max} at 250 °C	P_{max} at 20 °C	P_{max} at 150 °C	P_{max} at 200 °C	P_{max} at 250 °C
P02	32-160	-	-	-	-	-	40.0	40.0	40.0	40.0
	32-200	-	-	-	-	-	40.0	38.5	37.4	36.5
	40-160	40.0	40.0	40.0	36.6	34.9	40.0	40.0	40.0	40.0
	40-200	40.0	39.1	38.5	37.2	35.4	40.0	38.5	37.4	36.5
	50-160	40.0	40.0	40.0	38.6	36.8	40.0	40.0	40.0	40.0
P03	50-200	40.0	39.1	38.5	37.2	35.4	40.0	38.5	37.4	36.5
	32-250	-	-	-	-	-	40.0	40.0	40.0	40.0
	40-250	40.0	40.0	40.0	37.6	35.8	40.0	40.0	40.0	40.0
	40-315	-	-	-	-	-	40.0	40.0	40.0	40.0
	50-250	40.0	40.0	40.0	36.8	35.0	40.0	40.0	40.0	40.0
	50-315	-	-	-	-	-	40.0	40.0	40.0	40.0
	65-160	40.0	40.0	40.0	36.5	34.8	40.0	40.0	40.0	40.0
	65-200	38.2	36.0	35.5	34.5	33.5	39.0	35.4	34.4	33.6
	65-250	40.0	40.0	40.0	36.7	34.9	40.0	40.0	40.0	40.0
	80-160	40.0	40.0	40.0	37.0	35.2	40.0	40.0	40.0	40.0
P04	80-200	38.2	36.0	35.5	34.5	33.5	40.0	40.0	40.0	40.0
	80-250	40.0	40.0	40.0	37.3	35.5	40.0	40.0	40.0	40.0
	100-200	38.2	36.0	35.5	34.5	33.5	39.0	35.4	34.4	33.6
	65-315	-	-	-	-	-	40.0	40.0	40.0	40.0
	80-315	-	-	-	-	-	40.0	40.0	40.0	40.0

Casing bolts: spot-faced

admissible pressures in bar at °C

Calculation of casing to TFFSC without TRD

Limit conditioned by type series 40 bar $p/p' = 1.5$

Magnochem at a Glance

Hydraulics:

From the CPK pump series, well-proven more than 200,000 times

Casing cover:

available in variants for heating, external liquid feed and direct temperature measuring.

Cooling/lubrication:

forced circulation; minor temperature rise at the containment shroud, no NPSH deterioration.

Temperature monitoring at the containment shroud with PT 100 (option)

Anti-rub feature and assembling aid:

Protects the containment shroud from damage

Backup seal:

Prevents severe product leakage in the event of damage to the containment shroud (optional)

Casing:
heatable version available

Bearings secured
for large temperature range, insensitive to temperature changes

Drain:
Product drains off automatically at the lowest point of the containment shroud

Safety:

Pump with magnetic drive, absolutely leakage-free, with containment shroud made of Hastelloy C4. Only 2 static seals. Temperature and leakage monitoring possible.

Bearing assembly (rotor)

Sturdy plain bearings made of silicon carbide, product lubricated, for maximum service life. Diamond-coated bearings Sicodur Supra are optional

Heating:

Available for rotor space and/or lantern (option)

Handling:

Easy installation. When the drive unit is removed, the shroud remains bolted to the casing, thus sealing off the fluid (pump need not be drained).

Containment shroud:

Containment shroud up to PN 25 in Hastelloy, for optimum corrosion resistance at minimal eddy current losses

Economic viability:

Any existing CPK pump within the Magnochem selection range can be converted without any problems (Please refer to Magnochem selection chart)

Bearing assembly

(motor end): grease-lubricated rolling element bearings, sealed for life (Lh = 25000 h) (oil lubrication possible).

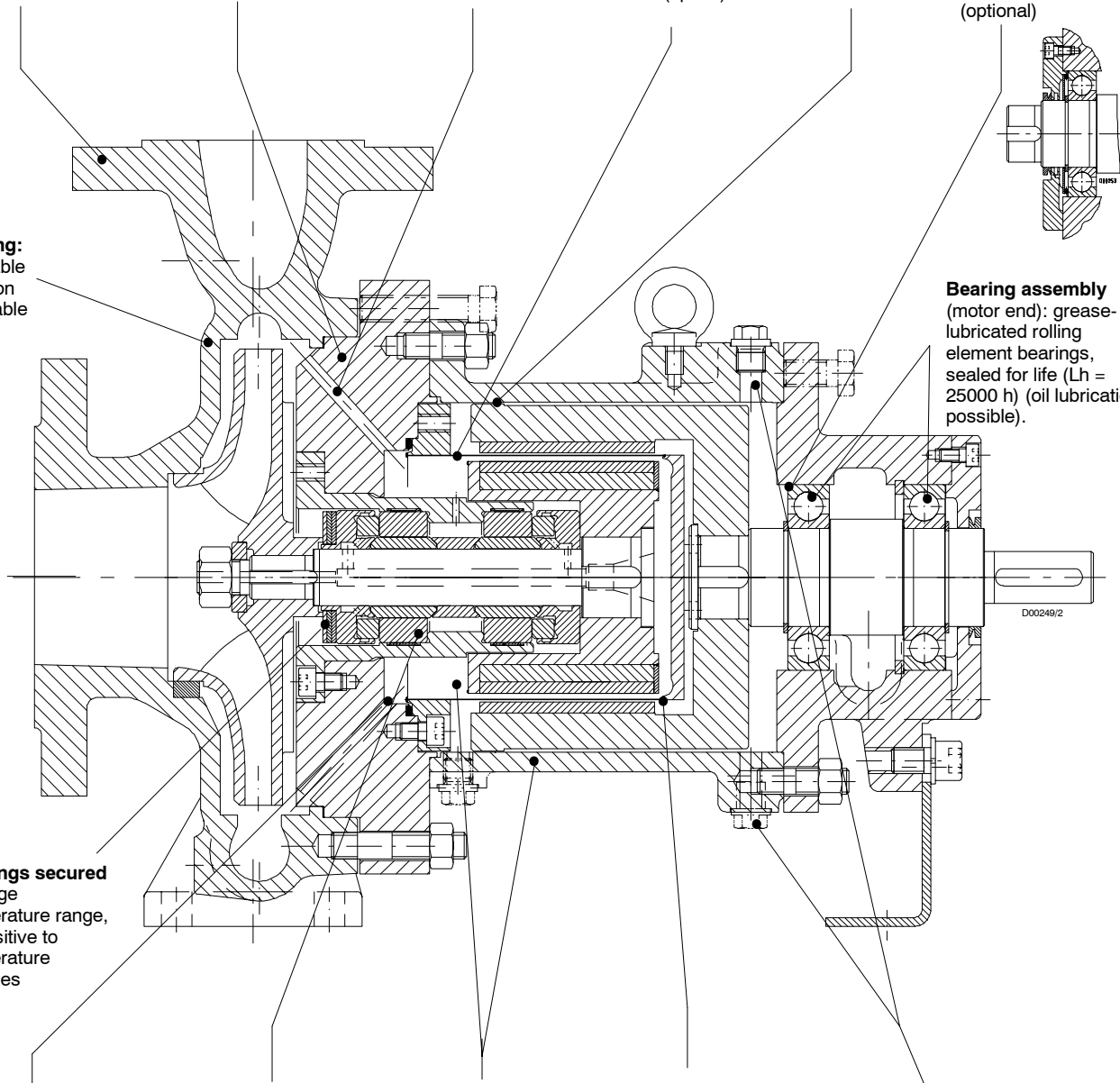

Specifications

		Pump sizes																			
		25-160	25-200	32-160	32-200	40-160	40-200	50-160	50-200	32-250	40-250	40-315	50-250	50-315	65-160	65-200	65-250	80-160	80-200	80-250	100-200
Bearing bracket		P 02									P 03										
General	corrosion allowance	mm 3																			
	impeller outlet width Ø	mm 6 6 7 7 9 7 15 12 6 7 8 10 8 20 16 13 27 22 17 29																			
	impeller inlet Ø	mm 45 45 52 52 65 65 82 82 52 65 65 84 84 89 96 96 100 114 114 122																			
	max. impeller Ø	mm see individual curve																			
	min. impeller Ø	mm see individual curve																			
Shaft dia.	at bearings (bearing bracket)																				
	pump end	mm 45									mm 45										
	motor end	mm 45									mm 45										
	pump end	mm																			
	motor end	mm																			
	at coupling	mm 24									mm 32										
Bearings	pump end	No 6209/C3-2RS1									No 6209/C3-2RS1										
	motor end	No 6209/C3-2RS1									No 6209/C3-2RS1										
	pump end	No																			
	motor end	No																			
Pressure limit	max. operating pressure	bar see diagram																			
	max. test pressure	bar 1.5 x permissible pump discharge pressure																			
Temp. limit	min./max. temp. of fluid handled	°C -40/280																			

		Pump sizes																	
		65-315	80-315	100-250	100-315	125-250	125-315	150-250	80-400	100-400	125-400	150-315	150-400	150-500	200-250	200-315	200-400	200-500	250-315
Bearing bracket		P 04								P 05									
General	corrosion allowance	mm 3																	
	impeller outlet width Ø	mm 10 14 23 19,5 32 26 46 11 15 20 38 29 23 62 50 40 23 73																	
	impeller inlet Ø	mm 96 129 129 135 154 154 180 118 129 154 190 190 190 190 222 222 222 270																	
	max. impeller Ø	mm see individual curve																	
	min. impeller Ø	mm see individual curve																	
Shaft dia.	at bearings (bearing bracket)																		
	pump end	mm 45 (110/165)								mm 80 (220)									
	motor end	mm 45 (110/165)								mm 80 (220)									
	pump end	mm 80 (220)																	
	motor end	mm 80 (220)																	
	at coupling	mm 42								mm 48									
Bearings	pump end	No 6209/C3-2RS1 (110/165)								No 6016/C3-2RS1 (220)									
	motor end	No 6209/C3-2RS1 (110/165)								No 6016/C3-2RS1 (220)									
	pump end	No 6016/C3-R2S1 (220)																	
	motor end	No 6016/C3-R2S1 (220)																	
Pressure limit	max. operating pressure	bar see diagram																	
	max. test pressure	bar 1.5 x permissible pump discharge pressure																	
Temp. limit	min./max. temp. of fluid handled	°C -40/280								°C -40/200									

Magnetic Coupling / Pump Size Combinations

Bearing bracket	Impeller Ø	Size of magnetic coupling		
		110-...	165-...	220-...
P 02	-160	X		
	-200	X		
P 03	-160	X	X	
	-200	X	X	
	-250	X	X	
P 04	-250	X	X	X
	-315	X	X	X
	-400			X
P 05	-250			X
	-315			X
	-400			X
	-500			X

110 - 60

 Length of magnet (mm)
 Shroud Ø (mm)

A computerized selection programme is used for dimensioning the magnetic coupling and determining the correct combination between magnetic coupling and pump size.

Pump Sizes

Discharge nozzle DN	Nominal impeller Ø						Bearing bracket
	160	200	250	315	400	500	
25	x	x					P 02
32	x	x	x				P 03
40	x	x	x	x			
50	x	x	x	x			
65	x	x	x	x			P 04
80	x	x ¹⁾	x ¹⁾	x ¹⁾	x		
100		x ¹⁾	x ¹⁾	x ¹⁾	x		
125			x	x	x		P 05
150			x	x	x	x	
200				x	x	x	
250				x			

□ Casing with double volute
 1) double volute; casing not available in material C1.

Balancing

On Magnochem pumps, axial forces are reduced by back vanes or by a discharge-side sealing gap with balancing holes, depending on the pump size.

The load acting on the thrust bearings is markedly reduced, which considerably increases operating reliability.

Documentation

- Printed documentation adapted to CE requirements
- general assembly drawing with list of components
 - general arrangement drawing / dimensions table
 - operating instructions

Forces and Moments

Magnochem pumps are designed for handling forces and moments in accordance with ISO 5199.

Heating

(optional: rotor space and/or lantern)
 Rotor space

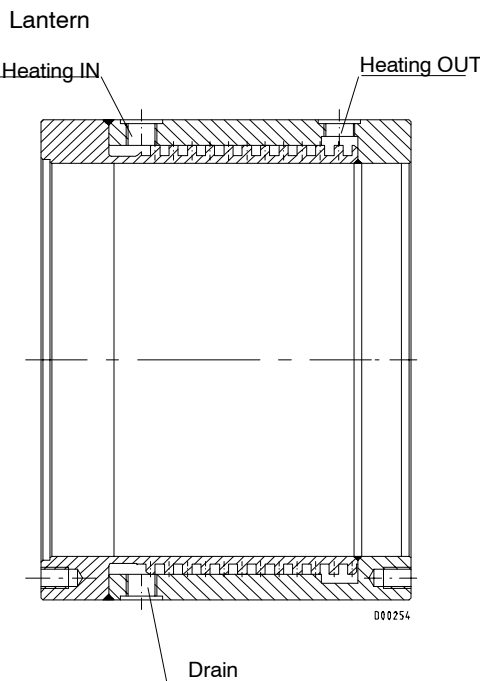
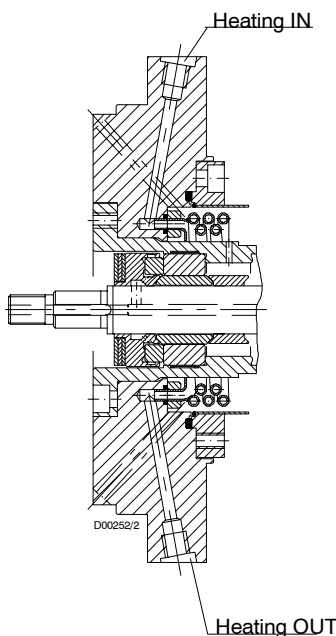

Heated lantern

t_{max} 120 °C
 P_{max} 10 bar

Casing

Radially split, consisting of volute casing (on Magnochem-S with casing wear ring) and casing cover.

The following pump sizes are available with heatable casing (Magnochem-CH):

Discharge nozzle DN	Nominal impeller Ø						Bearing bracket
	160	200	250	315	400	500	
25	x						P 02
32	x	x	x				P 03
40	x	x	x	x			
50	x	x	x	x			
65		x					P 04
80				x			
100							
125							P 05
150						x	
200 ^{*)}					x		
250 ^{*)}				x	x		

□ Casing with double volute
 *) Pressure/Temperature value of heating medium on request.

Casing Cover Variants

- **Standard design with internal circulation**
 (flushing connection possible)
- **External liquid feed (barrier liquid)**
- **Filter design**
 (flushing connection possible)

The above variants can be combined with heating (rotor space) and with each other.

Heating of Rotor Space

heating coil welded in			
hot water/saturated steam		heat transfer oil	
t _{max}	P _{max}	t _{max}	P _{max}
250 °C	20 bar	300 °C	6 bar

Dry-running Protection

If there is a risk of the pumps running dry, protection against dry-running must be provided for. This can be achieved by appropriate measures on site (pump power monitoring, flow meter, level meter, etc.), depending on the site conditions.

Accessories

- PT 100 (for monitoring the temperature at the containment shroud)
 - Pump power monitoring unit
- Other accessories on request.

Acceptance Tests / Guarantees

- **Materials tests**
Test report 2.2 on request
- **Product tests**
Inspection certificate 3.1 as per EN 10 204, on request, for: pressure test of complete pump
- **Hydraulic tests**

The following acceptance tests may be performed and certified at an extra charge:

Performance test ISO 9906
NPSH test

Warranties are given within the scope of the valid delivery conditions.

Coating and Preservation

(acc. to works standard AN 1865)

Magnochem-S, -E	< 150 °C	N 1 1 1 W
	≥ 150 °C	N 7 7 7 W
Magnochem-C1/C3	< 150 °C	N 0 1 1 U
	≥ 150 °C	N 0 7 7 U

Treatment of unmachined parts _____
 Coating - pressure-retaining parts _____
 Coating - bearing bracket, lantern, baseplate _____
 Coating - motor _____
 Preservation _____

N = reaction primer, parts in contact with the fluid handled without finish coat.

0 = without top coat

1 = synthetic enamel RAL 5002, ultramarine blue

7 = heat resistant paint RAL 9007 gray aluminum

U = untreated

W = rinsed with water repellent agent; blank parts liable to rust with protective coating

First Spare Parts Stock Recommended for Two Years' Operation after Commissioning

Part No.	Description		No. of pumps (incl. standby pumps)							10 and more
			2	3	4	5	6+7	8+9		
321.01	Deep-groove ball bearing	pcs.	1	1	2	2	3	4	50%	
321.02	Deep-groove ball bearing	pcs.	1	1	2	2	3	4	50%	
	Set of gaskets comprising: U-ring/Joint ring 411.08 Joint ring 411.01/.03/.10 V-ring 411.78	sets	2	2	3	3	3	4	50%	

List of Selected Spare Parts Recommended for Operation to DIN 24296

Part No.	Description		No. of pumps (incl. standby pumps)							10 and more
			2	3	4	5	6+7	8+9		
210.01	Shaft (outer rotor)	pcs.	1	1	1	2	2	2	20%	
210.03	Shaft (inner rotor)	pcs.	1	1	1	2	2	2	20%	
230	Impeller	pcs.	1	1	1	2	2	2	20%	
314.01	Thrust bearing	pcs.	1	1	2	2	3	4	50%	
314.02	Thrust bearing	pcs.	1	1	2	2	3	4	50%	
321.01	Deep-groove ball bearing	pcs.	1	1	2	2	3	4	50%	
321.02	Deep-groove ball bearing	pcs.	1	1	2	2	3	4	50%	
391.01	Bearing ring carrier	pcs.	1	1	2	2	3	4	50%	
411.08	U-ring/Joint ring	pcs.	2	2	3	3	3	4	50%	
411.01	Joint ring	pcs.	4	6	8	8	9	12	150%	
411.03	Joint ring	pcs.	4	6	8	8	9	12	150%	
411.10	Joint ring	pcs.	4	6	8	8	9	12	150%	
411.78	V-ring	pcs.	2	2	3	3	3	4	50%	
502.01	Casing wear ring (only for S variant)	pcs.	2	2	2	3	3	4	50%	
529.21/.22	Bearing sleeve	pcs.	1	1	2	2	3	4	50%	
509.21	Intermediate ring	pcs.	1	1	2	2	3	4	50%	
82-15	Containment shroud	pcs.	1	1	2	2	2	3	25%	
950.23	Cup spring	pcs.	1	1	2	2	3	4	50%	

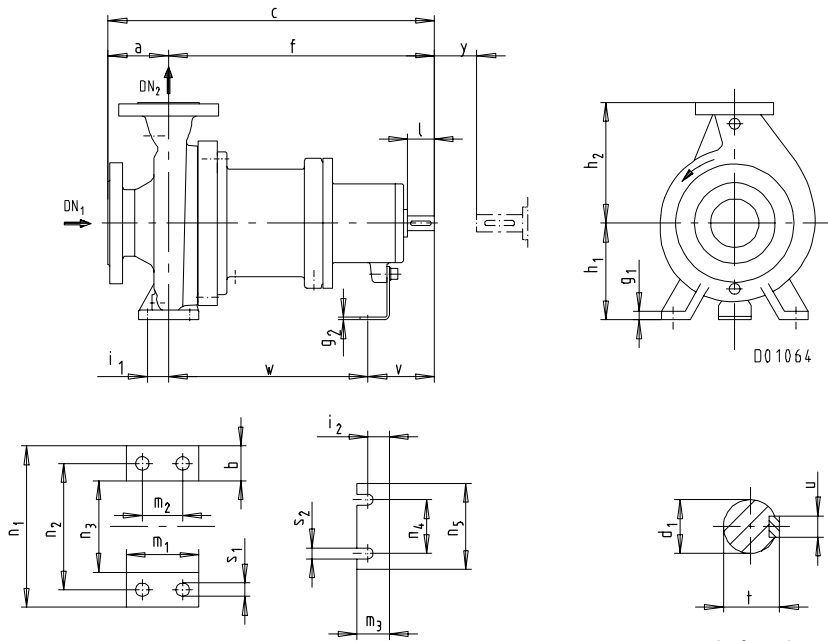
Dimensions

Flanges

Magnochem	Design	DN ₁	DN ₂
-C1	EN 1092-1, PN 16		
-CH Heatable casing	EN 1092, PN 16		
-S2	EN 1092-2, PN 25		
-S4	EN 1092-2, PN40		
-E	EN 1092-1, PN 25		
-E4	EN 1092-1, PN 40		
-C3.1	EN 1092-1, PN 16		
-C3.2	EN 1092-1, PN 25		

 shaft end
 key in acc. with DIN 6885/p. 1

y = clearance for dismantling without removing the motor

Pump size	Bearing bracket	Pump dimensions																Shaft end					Foot bolts									
		DN ₁	DN ₂	a	b	c	f	g ₁	g ₂	h ₁	h ₂	m ₁	m ₃	n ₁	n ₃	n ₅	d ₁ ø k ₆	l	t	u	y	i ₁	i ₂	m ₂	n ₂	n ₄	s ₁	s ₂	v	w		
25-160	P 02	40	25	80	50	465	385	14	4	132	160	100	48	240	140	160	24	50	27	8	100	35	20	70	190	110	14	14	100	285		
25-200	P 02	80	50	465	385	14	4	160	180	100	48	240	140	160	24	50	27	8	100	35	20	70	190	110	14	14	100	285				
32-160	P 02	50	32	80	50	465	385	14	4	132	160	100	48	240	140	160	24	50	27	8	100	35	20	70	190	110	14	14	100	285		
32-200	P 02	80	50	465	385	14	4	160	180	100	48	240	140	160	24	50	27	8	100	35	20	70	190	110	14	14	100	285				
32-250	P 03	100	65	600	500	16	4	180	225	125	48	320	190	160	32	80	35	10	100	47.5	20	95	250	110	14	14	130	370				
40-160	P 02	65	40	80	50	465	385	14	4	132	160	100	48	240	140	160	24	50	27	8	100	35	20	70	190	110	14	14	100	285		
40-200	P 02	100	65	600	500	16	4	180	225	125	48	320	190	160	32	80	35	10	100	47.5	20	95	250	110	14	14	130	370				
40-250	P 03	100	65	600	500	16	4	180	225	125	48	320	190	160	32	80	35	10	100	47.5	20	95	250	110	14	14	130	370				
40-315	P 03	125	65	625	500	18	6	200	250	125	48	345	215	160	32	80	35	10	100	47.5	20	95	280	110	14	14	130	370				
50-160	P 02	80	50	485	385	14	4	160	180	100	48	265	165	160	24	50	27	8	100	35	20	70	212	110	14	14	100	285				
50-200	P 02	100	65	600	500	16	4	180	225	125	48	320	190	160	32	80	35	10	100	47.5	20	95	250	110	14	14	130	370				
50-250	P 03	100	65	625	500	16	4	180	225	125	48	320	190	160	32	80	35	10	100	47.5	20	95	250	110	14	14	130	370				
50-315	P 03	125	65	625	500	18	6	225	280	125	48	345	215	160	32	80	37	10	100	47.5	20	95	280	110	14	14	130	370				
65-160	P 03	100	65	600	500	15	4	160	200	125	48	280	150	160	32	80	35	10	100	47.5	20	95	212	110	14	14	130	370				
65-200	P 03	100	65	600	500	16	4	180	225	125	48	320	190	160	32	80	35	10	140	47.5	20	95	250	110	14	14	130	370				
65-250	P 03	125	80	625	500	18	6	200	250	160	48	360	200	160	32	80	35	10	140	60	20	120	280	110	18	14	130	370				
65-315	P 04	125	80	655	530	18	6	225	280	160	48	400	240	160	42	110	45	12	140	60	20	120	315	110	18	14	160	370				
80-160	P 03	125	65	625	500	15	4	180	225	125	48	320	190	160	32	80	35	10	140	47.5	20	95	250	110	14	14	130	370				
80-200	P 03	125	65	625	500	16	4	180	250	125	48	345	215	160	32	80	35	10	140	47.5	20	95	280	110	14	14	130	370				
80-250	P 03	125	80	625	500	18	6	225	280	160	48	400	240	160	32	80	35	10	140	60	20	120	315	110	18	14	130	370				
80-315	P 04	125	80	655	530	18	6	250	315	160	48	400	240	160	42	110	45	12	140	60	20	120	315	110	18	14	160	370				
80-400	P 04	125	80	655	530	20	6	280	355	160	48	435	275	160	42	110	45	12	140	60	20	120	355	110	18	14	160	370				
100-200	P 03	125	80	625	500	16	6	200	280	160	48	360	200	160	32	80	35	10	140	60	20	120	280	110	18	14	130	370				
100-250	P 04	125	100	140	80	670	530	18	6	225	280	160	48	400	240	160	42	110	45	12	140	60	20	120	315	110	18	14	160	370		
100-315	P 04	140	80	670	530	18	6	250	315	160	48	400	240	160	42	110	45	12	140	60	20	120	315	110	18	14	160	370				
100-400	P 04	140	100	670	530	20	6	280	355	200	48	500	300	160	42	110	45	12	140	75	20	150	400	110	23	14	160	370				
125-250	P 04	150	125	140	80	670	530	18	6	250	355	160	48	400	240	160	42	110	45	12	140	60	20	120	315	110	18	14	160	370		
125-315	P 04	150	125	140	100	670	530	20	6	280	355	200	48	500	300	160	42	110	45	12	140	75	20	150	400	110	23	14	160	370		
125-400	P 04	150	125	140	100	670	530	20	6	315	400	200	48	500	300	160	42	110	45	12	140	75	20	150	400	110	23	14	160	370		
150-250	P 04	200	150	160	100	690	530	20	6	280	375	200	48	500	300	160	42	110	45	12	180	75	20	150	400	110	23	14	160	370		
150-315	P 05	200	150	160	100	830	670	22	12	315	400	200	60	550	350	200	48	110	51	14	180	75	39	150	450	140	23	18	170	500		
150-400	P 05	200	150	160	100	830	670	22	12	315	450	200	60	550	350	200	48	110	51	14	180	75	39	150	450	140	23	18	170	500		
150-500	P 05	200	150	180	100	850	670	22	12	375	500	200	60	550	350	200	48	110	51	14	180	75	39	150	450	140	23	18	170	500		
200-250	P 05	200	150	180	100	850	670	22	12	355	425	200	60	550	350	200	48	110	51	14	180	75	39	150	450	140	23	18	170	500		
200-315	P 05	250	200	200	110	870	670	22	12	355	450	200	60	550	350	200	48	110	51	14	180	75	39	150	450	140	23	18	170	500		
200-400	P 05	250	200	180	100	850	670	22	12	355	500	200	60	550	350	200	48	110	51	14	180	75	39	150	450	140	23	18	170	500		
200-500	P 05	250	200	200	100	870	670	22	12	425	560	200	60	660	460	200	48	110	51	14	180	75	39	150	560	140	23	18	170	500		
250-315	P 05	300	250	250	130	920	670	26	12	400	560	260	60	690	430	200	48	110	51	14	180	95	39	190	560	140	28	18	170	500		

 1) d₁ ø n₆

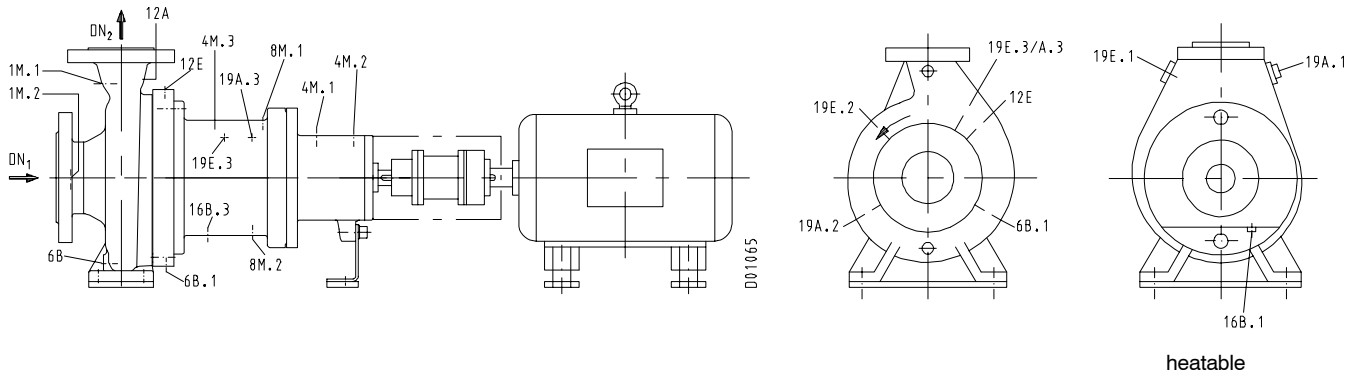
Connections

Connections	Size				Description	Connection by		Quantity required l/min	Pressure required bar	Max. pressure bar
	P02	P03	P04	P 05		customer	KSB			
	G = ISO 228/1									
1 M.1 ¹⁾	G 1/4	G 1/4	G 1/2	G 1/2	Pressure gauge					
1 M.2 ¹⁾	G 1/4	G 1/4	G 1/2	G 1/2	Pressure gauge					
4 M.1	G 1/4				Temperature sensor, rolling element bearings					
4 M.2	G 1/4				Temperature sensor, rolling element bearings					
4 M.3	G 1/4				Temperature sensor, shroud					
6 B	G 1/4	G 3/8	G 1/2	G 1/2	Casing drain					
6 B.1	G 1/4				Shroud drain for external liquid feed					
8 M.1	G 1/4				Leakage sensor (gas, vapour)					
8 M.2	G 1/4				Leakage sensor (liquid)					
12 E	G 1/4				Circulation liquid IN					
12 A	G 1/4				Circulation liquid OUT					
16B.1	G 1/4				Condensate drain (heated casing)					
16B.3	G 1/4			-	Condensate drain (heated lantern)					
19E.1	G 3/8				Heating IN (casing)					
19A.1	G 3/8				Heating OUT (casing)					
19E.2	G 3/8				Heating IN (casing cover)					
19A.2	G 3/8				Heating OUT (casing cover)					
19E.3	G 3/8			-	Heating IN (lantern)					
19A.3	G 3/8			-	Heating OUT (lantern)					

1) not applicable for heatable casing

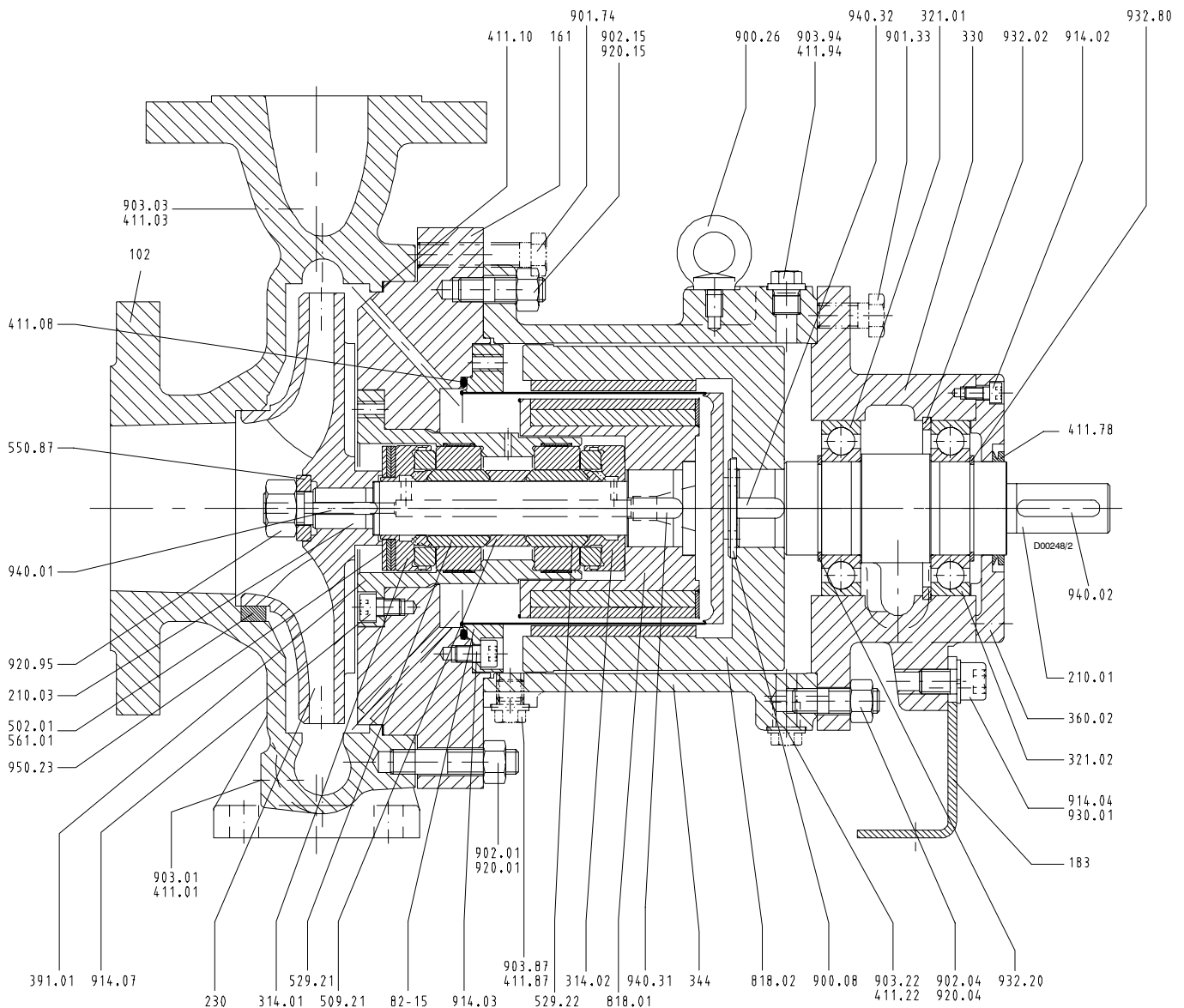
General Assembly Drawing

When ordering spare parts please always specify the type series/pump size, works No. (stamped on the name plate and on the suction nozzle flange), motor No. (serial No.), year of construction, quantity required, part No., description, material, fluid handled, general assembly drawing No. and mode of dispatch.

Part No.	Description	Scope of supply
102	Volute casing	with joint ring 411.01/.03/.10, casing wear ring 502.01 ¹⁾ , grooved pin 561.01 ¹⁾ , stud 902.01, screwed plug 903.01/.03, hex. nut 920.01
161	Casing cover	with U-ring/joint ring 411.08, joint ring 411.10, hex. head bolt 901.74, stud 902.15, hex. nut 920.15
183	Support foot	with socket head cap screw 914.04, lockwasher 930.01
210.01	Shaft	with screw 900.08, circlip 932.20/.80, key 940.02/.32
210.03	Shaft	with spacer ring 504.02, disc 550.87, hex. nut 920.95, key 940.01/.31
230	Impeller	
310	Bearing assembly (plain bearings)	consisting of axial plain bearing 314.01/.02, bearing ring carrier 391.01, intermediate ring 509.21, bearing sleeve 529.21/.22, socket head cap screw 914.07, cup spring 950.23
321.01/.02	Deep-groove ball bearing	
330	Bearing bracket	with bearing cover 360.02, socket head cap screw 914.02, circlip 932.02
344	Bearing bracket lantern	with joint ring 411.22/.87/.94, eyebolt 900.26, hex. head bolt 901.33, stud 902.04, screwed plug 903.22/.87/.94, hex. nut 920.04
360.02	Bearing cover	with joint ring 411.78, hex. socket head cap screw 914.02
82-15	Shroud	with socket head cap screw 914.03
818.01	Inner rotor	complete
818.02	Outer rotor	complete

¹⁾ on Magnochem-S only

