

MARATHON®

A WARREN RUPP PUMP BRAND



SUBMERSIBLE SLUDGEMASTER™

AIR-OPERATED PUMP MSMA3-A

UNIQUE AND VARIED BENEFITS OF THE AIR-OPERATED SLUDGEMASTER™

- **Immediate ease of use**, simply hook up compressed air supply, lower through man-hole, into sump or fluid to be pumped. No fuel tanks to run empty, no gas cans to carry, no electrical connections, no electric motors to overload.
- **Keeps pumping without clogging** on most problem jobs. Won't choke up on small trash. Can run dry with no damage.
- **Self-draining** to prevent damage in below freezing weather.
- **Self-priming.**
- **High capacity, low head operation** to meet nearly every emergency or daily use application.
- **Continuous automatic lubricating** internal oiler, oil-batch-lubricated shaft seal; needs only 1 pint (.47 liter) every 50 hours of use.
- **Foolproof design** has two vane, low speed, trash-type cast iron impeller that handles abrasive substances with less wear.
- **Sturdy build** for rough handling and long life endurance on land, sea or offshore.

Submersible SludgeMaster™

Air-Operated Pump Model MSMA3-A

SludgeMaster™ High Performance Features:

Powered by 2½hp Gast 6am direct-drive air motor. Cast iron, vane-type. Independent of pump. Complete motor replacement costs less than repairs for many other pumps.

Air-Inlet: ½" (12.5mm) NPT fitted with universal hose coupling (hidden from view in this photo) Flow speed easily adjustable.

Exhaust muffler for quiet operation (hidden from view in this photo).

Completely sealed aluminum housing encloses all mechanical parts.

3" (75mm) NPT female pipe thread discharge.

Trash-type, plated steel strainer with ½" square openings...easily removed for access to lower wear plate and impeller. Optional screen available to reduce solids-handling to ½" (12.5mm) diameter.

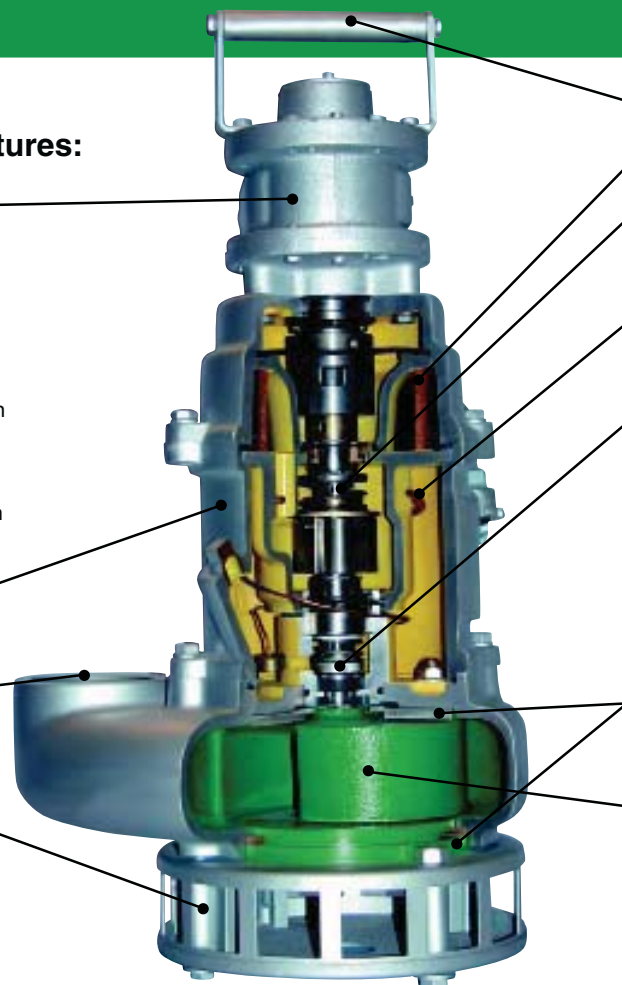

Carrying handle.

Large built-in air filter.

Built-in speed-limiting governor prevents damage if pump runs dry for extended periods of time.

Automatic oiler dispenses proper amount of lubricant into air stream; eliminates need for an external oiler.

Face-type mechanical shaft seal operates in 1-quart (.95liter) of oil under full-line air pressure. Oil pressure at seal always exceeds pressure of pumped liquid thus provides a clean oil environment at seal for long life even under abrasive conditions. Should seal failure eventually occur, unique seal design prevents entrance of pumped liquid and any further damage.

Replaceable wear plates on both sides of impeller are made of iron and steel for maximum wear resistance.

Two-vane trash-type open impeller of cast iron for wear and impact resistance; can be removed without disturbing seal.

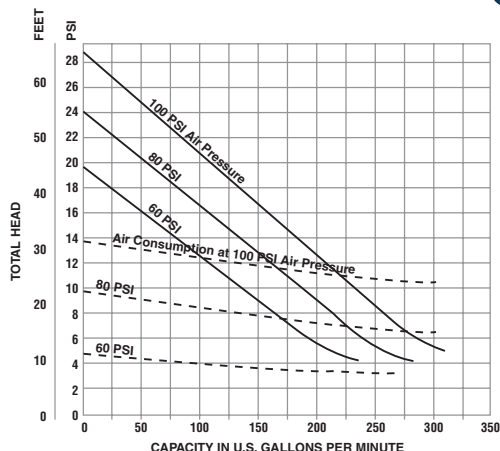

Performance Curves

