

## CR(E), CRI(E), CRN(E) 10

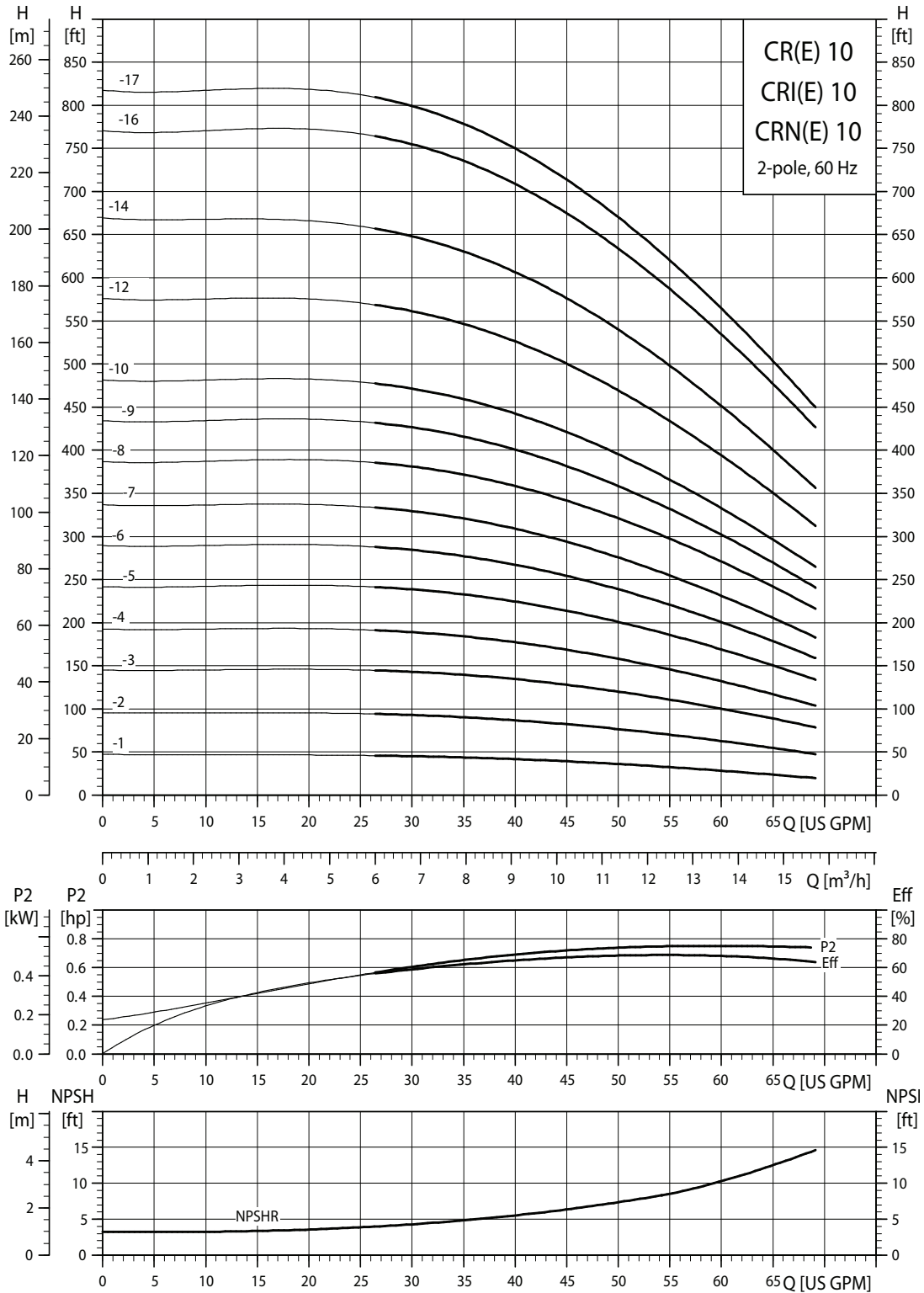

TM02 7221 3704

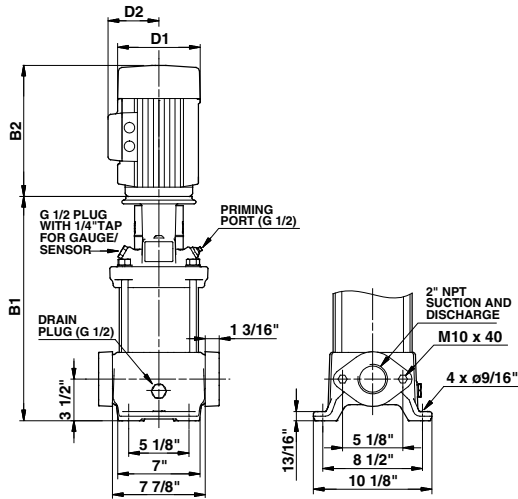

TM03 1460 2205

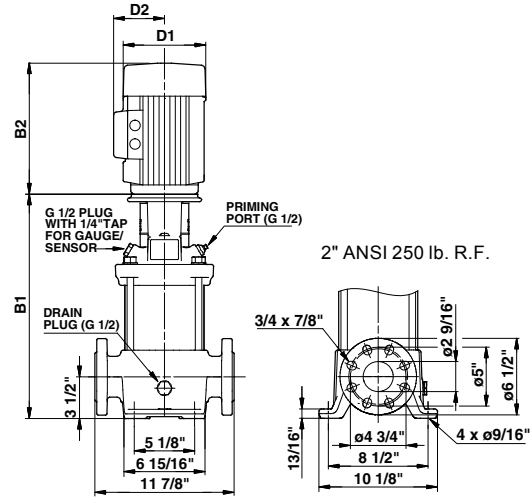

TM03 1461 2205

Pump type	P2 [hp]	Ph.	Oval*	ANSI dimensions [inch]						Ship Wt. [lbs.]	ANSI dimensions [inch]			Ship Wt. [lbs.]	
				B1	TEFC			ODP			MLE				
					D1	D2	B1+B2	D1	D2		B1+B2	D1	D2		B1+B2
CR(E) 10-1	3/4	1	•	15.28	7.19	5.73	26.47	-	-	-	115	5.55	5.51	24.26	108
		3	•	15.28	5.55	4.57	22.72	-	-	-	106	7.01	6.57	28.08	128
CR(E) 10-2	1 1/2	1	•	15.28	7.19	5.73	26.96	-	-	-	128	-	-	-	-
		3	•	15.28	5.55	4.57	23.90	-	-	-	106	7.01	6.57	28.08	128
CR 10-3	3	1	•	17.20	8.60	6.87	31.85	-	-	-	183	-	-	-	-
		3	•	17.20	7.01	4.33	30.43	-	-	-	153	-	-	-	-
CR(E) 10-4	3	1	•	18.39	8.60	6.87	33.04	-	-	-	183	-	-	-	-
		3	•	18.39	7.01	4.33	31.62	-	-	-	156	7.01	6.57	31.70	163
CR 10-5	5	1	•	19.57	10.62	7.46	35.09	-	-	-	209	-	-	-	-
		3	•	19.57	8.66	5.28	35.08	-	-	-	206	-	-	-	-
CR(E) 10-6	5	1	•	20.75	10.62	7.46	36.27	-	-	-	212	-	-	-	-
		3	•	20.75	8.66	5.28	36.26	-	-	-	208	8.66	7.40	36.26	201
CR 10-7	7 1/2	1	-	22.25	10.22	7.62	37.78	-	-	-	232	-	-	-	-
		3	-	22.25	8.66	5.28	37.76	-	-	-	221	-	-	-	-
CR(E) 10-8	7 1/2	1	-	23.43	10.22	7.62	38.96	-	-	-	234	-	-	-	-
		3	-	23.43	8.66	5.28	38.94	-	-	-	223	8.66	7.40	38.94	236
CR 10-9	7 1/2	1	-	24.61	10.22	7.62	40.14	-	-	-	236	-	-	-	-
		3	-	24.61	8.66	5.28	40.12	-	-	-	225	-	-	-	-
CR(E) 10-10	7 1/2	1	-	25.79	10.22	7.62	41.32	-	-	-	238	-	-	-	-
		3	-	25.79	8.66	5.28	41.30	-	-	-	227	8.66	7.40	41.30	240
CR(E) 10-12	10	1	-	28.15	10.23	10.30	44.22	-	-	-	355	-	-	-	-
		3	-	28.15	8.66	5.28	43.66	-	-	-	232	10.24	8.39	43.07	251
CR(E) 10-14	15	3	-	33.06	10.22	8.67	49.64	10.62	7.33	49.37	443	13.39	12.13	51.84	504
CR 10-16	15	3	-	35.43	10.22	8.67	52.01	10.62	7.33	51.74	451	-	-	-	-
CR(E) 10-17	15	3	-	37.80	10.22	8.67	54.38	10.62	7.33	54.11	455	13.39	12.13	56.58	519

All dimensions in inches unless otherwise noted.

\*Oval flanged pump B1 and B1+B2 dimension is equal to ANSI flanged pumps and weight is approximately 3 lbs. less.

• Available.

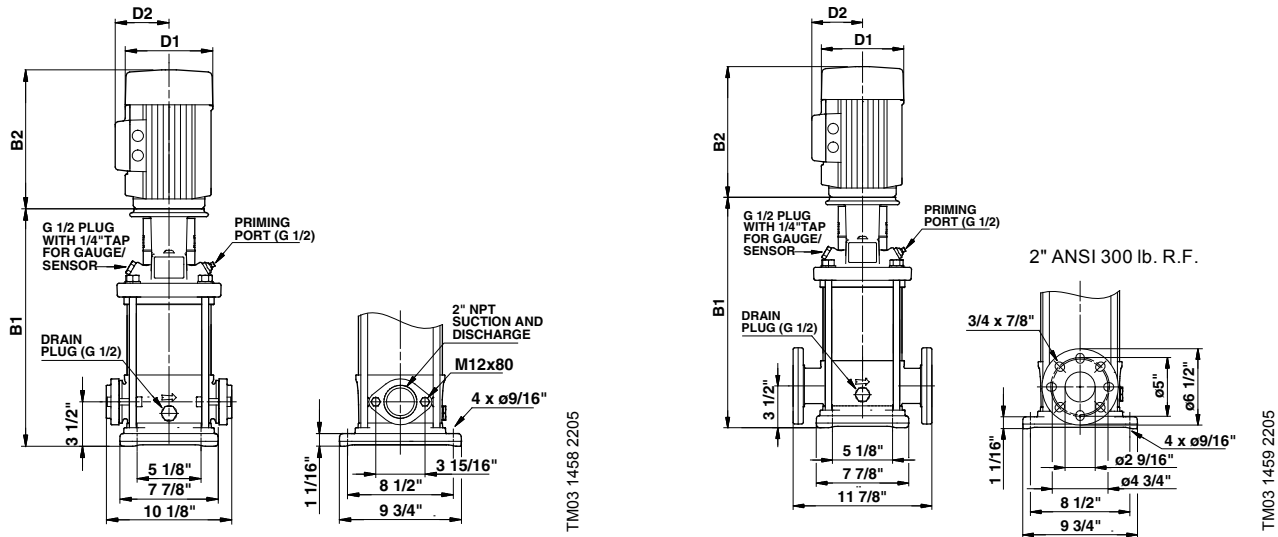

Pump type	P2 [hp]	Ph.	Oval*	ANSI dimensions [inch]						Ship Wt. [lbs.]	ANSI dimensions [inch]			Ship Wt. [lbs.]	
				B1	TEFC			ODP			MLE				
					D1	D2	B1+B2	D1	D2		B1+B2	D1	D2		B1+B2
CRI(E) 10-1	1	1	•	15.20	7.19	5.73	26.39	-	-	-	106	5.55	5.51	24.18	97
		3	•	15.20	5.55	4.57	22.64	-	-	-	97	7.01	6.57	28.00	119
CRI(E) 10-2	1 1/2	1	•	15.20	7.19	5.73	26.88	-	-	-	121	-	-	-	-
		3	•	15.20	5.55	4.57	23.82	-	-	-	99	7.01	6.57	28.00	119
CRI 10-3	3	1	•	17.13	8.60	6.87	31.78	-	-	-	174	-	-	-	-
		3	•	17.13	7.01	4.33	30.36	-	-	-	147	-	-	-	-
CRI(E) 10-4	3	1	•	18.31	8.60	6.87	32.96	-	-	-	176	-	-	-	-
		3	•	18.31	7.01	4.33	31.54	-	-	-	147	7.01	6.57	31.62	157
CRI 10-5	5	1	•	19.49	10.62	7.46	35.01	-	-	-	203	-	-	-	-
		3	•	19.49	8.66	5.28	35.00	-	-	-	199	-	-	-	-
CRI(E) 10-6	5	1	•	20.67	10.62	7.46	36.19	-	-	-	205	-	-	-	-
		3	•	20.67	8.66	5.28	36.18	-	-	-	201	8.66	7.40	36.18	194
CRI 10-7	7 1/2	1	•	22.17	10.22	7.62	37.70	-	-	-	225	-	-	-	-
		3	•	22.17	8.66	5.28	37.68	-	-	-	212	-	-	-	-
CRI(E) 10-8	7 1/2	1	•	23.35	10.22	7.62	38.88	-	-	-	227	-	-	-	-
		3	•	23.35	8.66	5.28	38.86	-	-	-	214	8.66	7.40	38.86	229
CRI 10-9	7 1/2	1	•	24.53	10.22	7.62	40.06	-	-	-	229	-	-	-	-
		3	•	24.53	8.66	5.28	40.04	-	-	-	216	-	-	-	-
CRI(E) 10-10	7 1/2	1	•	25.71	10.22	7.62	41.24	-	-	-	232	-	-	-	-
		3	•	25.71	8.66	5.28	41.22	-	-	-	218	8.66	7.40	41.22	234
CRI(E) 10-12	10	1	-	28.07	10.23	10.30	44.14	-	-	-	346	-	-	-	-
		3	-	28.07	8.66	5.28	43.58	-	-	-	225	10.24	8.39	42.99	243
CRI(E) 10-14	15	3	-	32.95	10.22	8.67	49.53	10.62	7.33	49.26	432	13.39	12.13	51.73	497
CRI 10-16	15	3	-	35.31	10.22	8.67	51.89	10.62	7.33	51.62	442	-	-	-	-
CRI(E) 10-17	15	3	-	37.68	10.22	8.67	54.26	10.62	7.33	53.99	447	13.39	12.13	56.46	513

All dimensions in inches unless otherwise noted.

\*Oval flanged pump B1 and B1+B2 dimension is equal to ANSI flanged pumps and weight is approximately 7 lbs. less.

• Available.

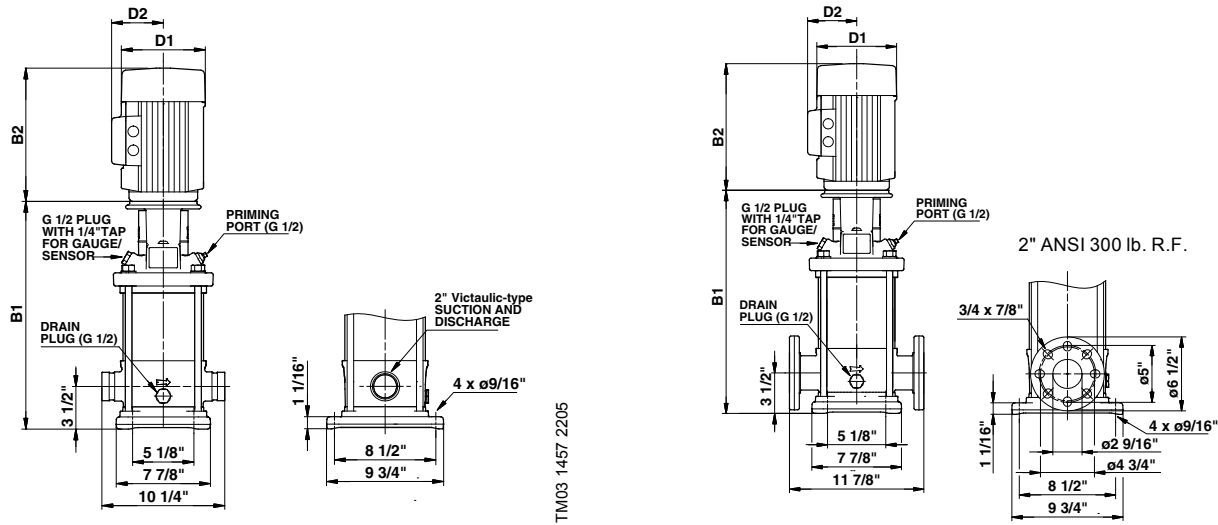

TM03 1457 2205

TM03 1459 2205

Pump type	P2 [hp]	Ph.	PJE*	ANSI dimensions [inch]							Ship Wt. [lbs.]	ANSI dimensions [inch]				Ship Wt. [lbs.]
				B1	TEFC			ODP				MLE				
					D1	D2	B1+B2	D1	D2	B1+B2		D1	D2	B1+B2		
CRN(E) 10-1	1	1	•	15.20	7.19	5.73	26.39	-	-	-	106	5.55	5.51	24.18	97	
		3	•	15.20	5.55	4.57	22.64	-	-	-	97	7.01	6.57	28.00	119	
CRN(E) 10-2	1 1/2	1	•	15.20	7.19	5.73	26.88	-	-	-	121	-	-	-	-	
		3	•	15.20	5.55	4.57	23.82	-	-	-	99	7.01	6.57	28.00	119	
CRN 10-3	3	1	•	17.13	8.60	6.87	31.78	-	-	-	176	-	-	-	-	
		3	•	17.13	7.01	4.33	30.36	-	-	-	147	-	-	-	-	
CRN(E) 10-4	3	1	•	18.31	8.60	6.87	32.96	-	-	-	176	-	-	-	-	
		3	•	18.31	7.01	4.33	31.54	-	-	-	149	7.01	6.57	31.62	157	
CRN 10-5	5	1	•	19.49	10.62	7.46	35.01	-	-	-	203	-	-	-	-	
		3	•	19.49	8.66	5.28	35.00	-	-	-	199	-	-	-	-	
CRN(E) 10-6	5	1	•	20.67	10.62	7.46	36.19	-	-	-	205	-	-	-	-	
		3	•	20.67	8.66	5.28	36.18	-	-	-	201	8.66	7.40	36.18	194	
CRN 10-7	7 1/2	1	•	22.17	10.22	7.62	37.70	-	-	-	227	-	-	-	-	
		3	•	22.17	8.66	5.28	37.68	-	-	-	214	-	-	-	-	
CRN(E) 10-8	7 1/2	1	•	23.35	10.22	7.62	38.88	-	-	-	229	-	-	-	-	
		3	•	23.35	8.66	5.28	38.86	-	-	-	216	8.66	7.40	38.86	229	
CRN 10-9	7 1/2	1	•	24.53	10.22	7.62	40.06	-	-	-	232	-	-	-	-	
		3	•	24.53	8.66	5.28	40.04	-	-	-	218	-	-	-	-	
CRN(E) 10-10	7 1/2	1	•	25.71	10.22	7.62	41.24	-	-	-	234	-	-	-	-	
		3	•	25.71	8.66	5.28	41.22	-	-	-	221	8.66	7.40	41.22	234	
CRN(E) 10-12	10	1	•	28.07	10.23	10.30	44.14	-	-	-	346	-	-	-	-	
		3	•	28.07	8.66	5.28	43.58	-	-	-	225	10.24	8.39	42.99	243	
CRN(E) 10-14	15	3	•	32.95	10.22	8.67	49.53	10.62	7.33	49.25	432	13.39	12.13	51.73	497	
CRN 10-16	15	3	•	35.31	10.22	8.67	51.89	10.62	7.33	51.63	442	-	-	-	-	
CRN(E) 10-17	15	3	•	37.68	10.22	8.67	54.26	10.62	7.33	54.00	447	13.39	12.13	56.46	513	

All dimensions in inches unless otherwise noted.

\*PJE flanged pump B1 and B1+B2 dimension is equal to ANSI flanged pumps and weight is approximately 9 lbs. less.

• Available