

CR(E), CRI(E), CRN(E) 15

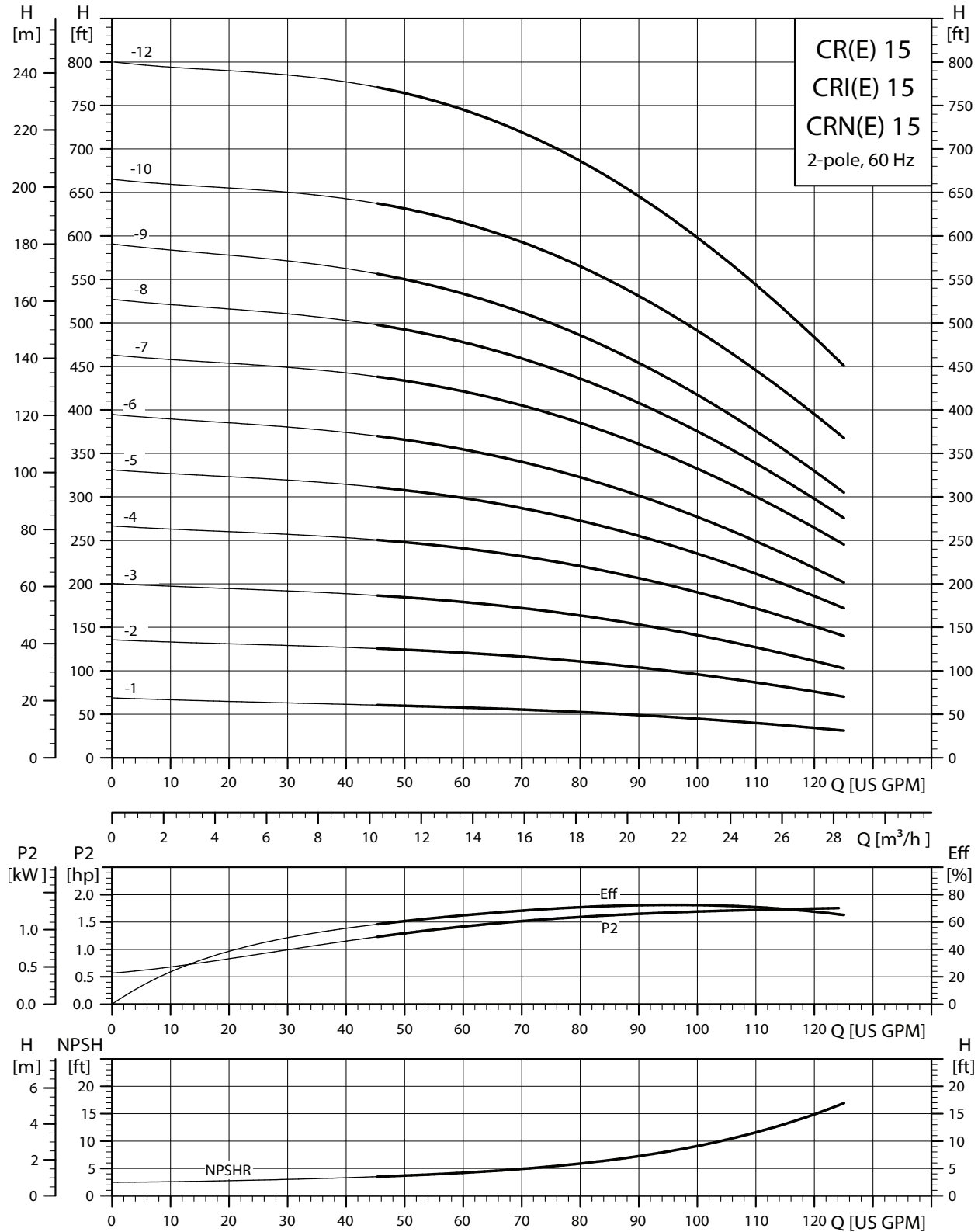

TM02 7222 2803

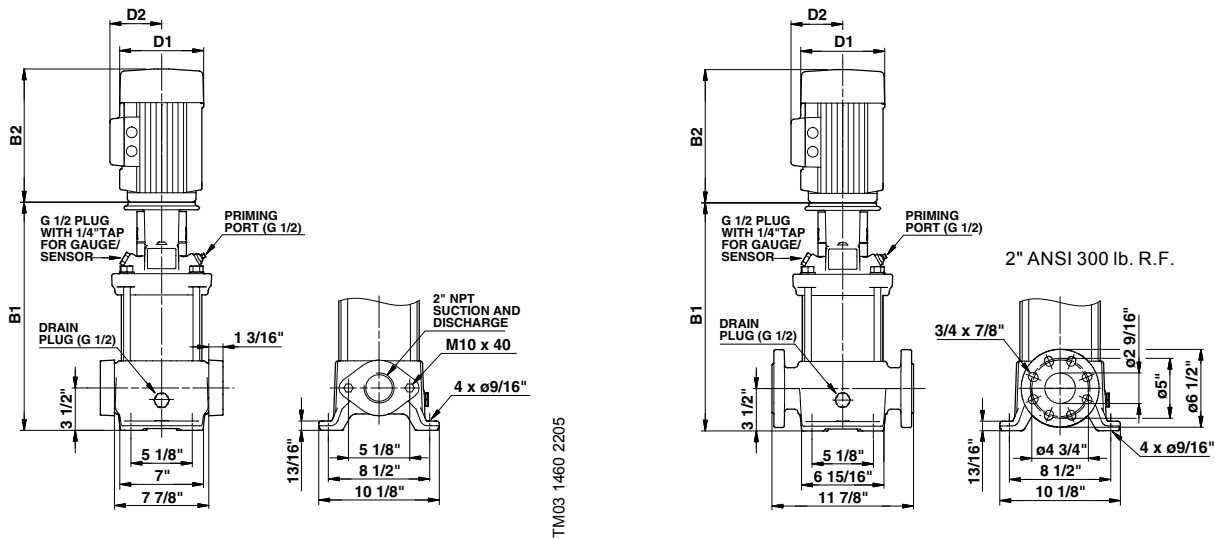

Pump type	P2 [hp]	Ph.	Oval*	ANSI dimensions [inch]									Ship Wt. [lbs.]		
				B1	TEFC			ODP			MLE				
					D1	D2	B1+B2	D1	D2	B1+B2	D1	D2		B1+B2	
CR(E) 15-1	2	1	•	16.46	7.19	5.73	29.02	-	-	-	139	-	-	-	-
		3	•	16.46	7.01	4.33	27.68	-	-	-	128	7.01	6.57	29.26	141
CR(E) 15-2	5	1	•	17.20	10.62	7.46	32.72	-	-	-	205	-	-	-	-
		3	•	17.20	8.66	5.28	32.71	-	-	-	201	8.66	7.40	30.00	194
CR(E) 15-3	7 1/2	1	•	19.29	10.22	7.62	34.82	-	-	-	223	-	-	-	-
		3	•	19.29	8.66	5.28	34.80	-	-	-	212	8.66	7.40	19.29	206
CR(E) 15-4	7 1/2	1	•	21.06	10.22	7.62	36.59	-	-	-	225	-	-	-	-
		3	•	21.06	8.66	5.28	36.57	-	-	-	214	8.66	7.40	34.37	227
CR(E) 15-5	10	1	•	22.83	10.23	10.30	38.90	-	-	-	342	-	-	-	-
		3	•	22.83	8.66	5.28	38.34	-	-	-	218	10.24	8.39	22.83	238
CR(E) 15-6	15	3	-	27.17	10.22	8.67	43.75	10.62	7.33	43.48	376	13.39	12.13	45.95	402
CR 15-7	15	3	-	28.94	10.22	8.67	45.52	10.62	7.33	45.25	407	-	-	-	-
CR(E) 15-8	15	3	-	30.71	10.22	8.67	47.29	10.62	7.33	47.02	438	13.39	12.13	49.49	504
CR 15-9	20	3	-	32.48	10.22	8.67	49.06	11.50	8.92	52.17	446	-	-	-	-
CR(E) 15-10	20	3	-	34.25	10.22	8.67	50.83	11.50	8.92	53.94	450	13.39	12.13	53.03	517
CR(E) 15-12	25	3	-	37.17	12.94	11.52	56.99	11.50	8.94	57.98	505	13.39	12.13	59.89	552

All dimensions in inches unless otherwise noted.

*Oval flanged pump B1 and B1+B2 dimension is equal to ANSI flanged pumps and weight is approximately 3 lbs. less.

• Available.

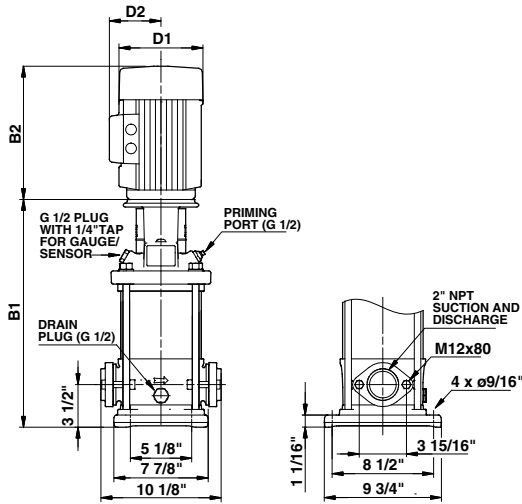

TM03 1458 2205

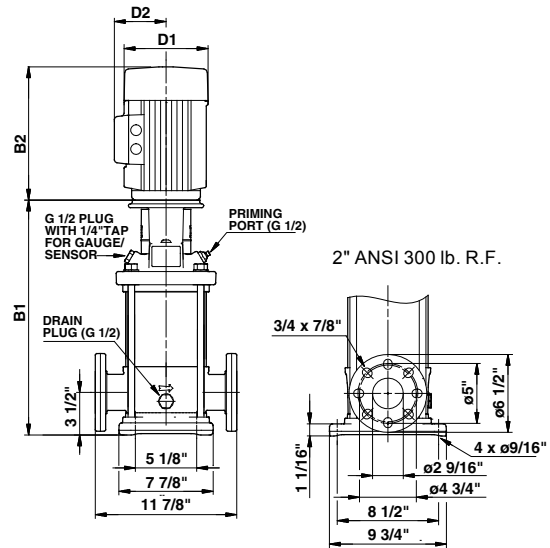

TM03 1459 2205

Pump type	P2 [hp]	Ph.	Oval*	ANSI dimensions [inch]						Ship Wt. [lbs.]	ANSI dimensions [inch]			Ship Wt. [lbs.]	
				B1	TEFC			ODP			MLE				
					D1	D2	B1+B2	D1	D2		B1+B2	D1	D2		B1+B2
CRI(E) 15-1	2	1	•	16.38	7.19	5.73	28.94	-	-	-	130	-	-	-	-
				16.38	7.01	4.33	27.60	-	-	-	7.01	6.57	29.18	135	
CRI(E) 15-2	5	1	•	17.13	10.62	7.46	32.65	-	-	-	198	-	-	-	-
				17.13	8.66	5.28	32.64	-	-	-	8.66	7.40	29.93	185	
CRI(E) 15-3	7 1/2	1	•	19.21	10.22	7.62	34.74	-	-	-	216	-	-	-	-
				19.21	8.66	5.28	34.72	-	-	-	8.66	7.40	19.21	200	
CRI(E) 15-4	7 1/2	1	•	20.98	10.22	7.62	36.51	-	-	-	218	-	-	-	-
				20.98	8.66	5.28	36.49	-	-	-	8.66	7.40	34.29	218	
CRI(E) 15-5	10	1	•	22.76	10.23	10.30	38.83	-	-	-	333	-	-	-	-
				22.76	8.66	5.28	38.27	-	-	-	10.24	8.39	22.76	229	
CRI(E) 15-6	15	3	•	27.05	10.22	8.67	43.63	10.62	7.33	43.36	365	13.39	12.13	45.83	477
CRI 15-7	15	3	•	28.82	10.22	8.67	45.40	10.62	7.33	45.13	398	-	-	-	-
CRI(E) 15-8	15	3	•	30.59	10.22	8.67	47.17	10.62	7.33	46.90	431	13.39	12.13	49.37	495
CRI 15-9	20	3	-	32.36	10.22	8.67	48.94	11.50	8.92	52.05	439	-	-	-	-
CRI(E) 15-10	20	3	-	34.13	10.22	8.67	50.71	11.50	8.92	53.82	442	13.39	12.13	52.91	510
CRI(E) 15-12	25	3	-	37.05	12.94	11.52	56.87	11.50	8.94	57.86	496	13.39	12.13	59.77	543

All dimensions in inches unless otherwise noted.

*Oval flanged pump B1 and B1+B2 dimension is equal to ANSI flanged pumps and weight is approximately 7 lbs. less.

• Available.

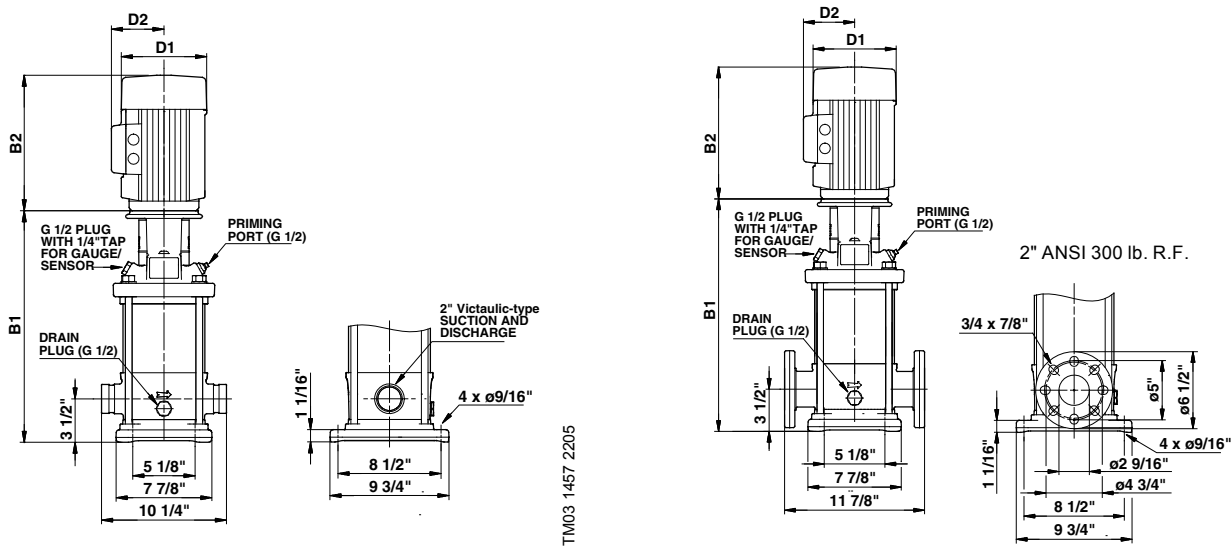

Pump type	P2 [hp]	Ph.	PJE*	ANSI dimensions [inch]									ANSI dimensions [inch]			
				B1	TEFC			ODP			Ship Wt. [lbs.]	MLE			Ship Wt. [lbs.]	
					D1	D2	B1+B2	D1	D2	B1+B2		D1	D2	B1+B2		
CRN(E) 15-1	2	1	•	16.38	7.19	5.73	28.94	-	-	-	130	-	-	-	-	
		3	•	16.38	7.01	4.33	27.60	-	-	-	121	7.01	6.57	29.18	135	
CRN(E) 15-2	5	1	•	17.44	10.62	7.46	32.96	-	-	-	203	-	-	-	-	
		3	•	17.13	8.66	5.28	32.64	-	-	-	195	8.66	7.40	29.93	185	
CRN(E) 15-3	7 1/2	1	•	19.21	10.22	7.62	34.74	-	-	-	216	-	-	-	-	
		3	•	19.21	8.66	5.28	34.72	-	-	-	205	8.66	7.40	19.21	200	
CRN(E) 15-4	7 1/2	1	•	20.98	10.22	7.62	36.51	-	-	-	218	-	-	-	-	
		3	•	20.98	8.66	5.28	36.49	-	-	-	207	8.66	7.40	34.29	221	
CRN(E) 15-5	10	1	•	22.76	10.23	10.30	38.83	-	-	-	335	-	-	-	-	
		3	•	22.76	8.66	5.28	38.27	-	-	-	214	10.24	8.39	22.76	232	
CRN(E) 15-6	15	3	•	27.05	10.22	8.67	43.63	10.62	7.33	43.36	365	13.39	12.13	45.83	477	
CRN 15-7	15	3	•	28.82	10.22	8.67	45.40	10.62	7.33	45.13	398	-	-	-	-	
CRN(E) 15-8	15	3	•	30.59	10.22	8.67	47.17	10.62	7.33	46.90	431	13.39	12.13	49.37	495	
CRN 15-9	20	3	•	32.36	10.22	8.67	48.94	11.50	8.92	52.05	439	-	-	-	-	
CRN(E) 15-10	20	3	•	34.13	10.22	8.67	50.71	11.50	8.92	53.82	442	13.39	12.13	52.91	510	
CRN(E) 15-12	25	3	•	37.05	12.94	11.52	56.87	11.50	8.94	57.86	496	13.39	12.13	59.77	543	

All dimensions in inches unless otherwise noted.

*PJE flanged pump B1 and B1+B2 dimension is equal to ANSI flanged pump and weight is approximately 9 lbs. less.

• Available.