

CR(E), CRI(E), CRN(E) 20

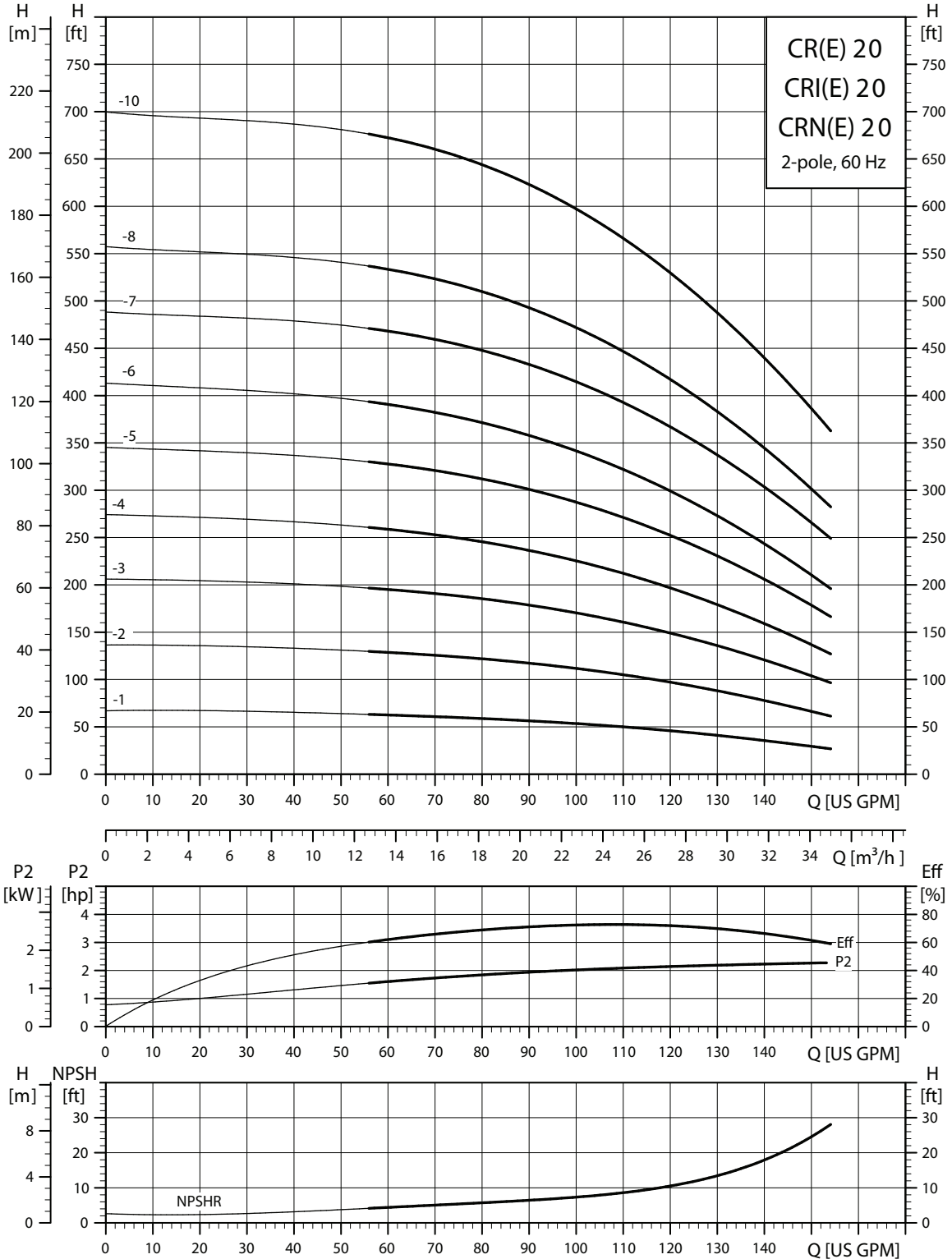

TM02 7223 2803

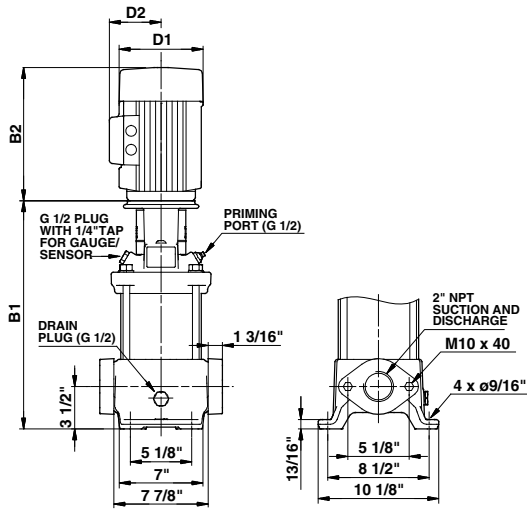

TM03 1460 2205

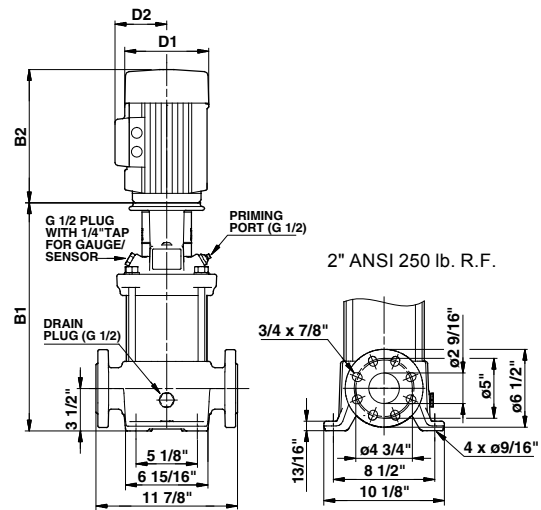

TM03 1461 2205

Pump type	P2 [hp]	Ph.	Dimensions [inch]							Ship Wt. [lbs.]	Dimensions [inch]			Ship Wt. [lbs.]	
			Oval*	B1	TEFC			ODP			MLE				
					D1	D2	B1+B2	D1	D2		B1+B2	D1	D2		B1+B2
CR(E) 20-1	3	1	•	17.20	8.60	6.87	31.85	-	-	-	181	-	-	-	-
		3	•	17.20	7.01	4.33	30.43	-	-	-	151	7.01	6.57	30.00	161
CR(E) 20-2	5	1	•	17.20	10.62	7.46	32.72	-	-	-	205	-	-	-	-
		3	•	17.20	8.66	5.28	32.71	-	-	-	201	8.66	7.40	30.00	194
CR(E) 20-3	7 1/2	1	•	19.29	10.22	7.62	34.82	-	-	-	223	-	-	-	-
		3	•	19.29	8.66	5.28	34.80	-	-	-	209	8.66	7.40	19.29	223
CR(E) 20-4	10	1	•	21.06	10.23	10.30	37.13	-	-	-	337	-	-	-	-
		3	•	21.06	8.66	5.28	36.57	-	-	-	214	10.24	8.39	34.37	232
CR(E) 20-5	15	3	•	25.39	10.22	8.67	41.97	10.62	7.33	41.70	398	13.39	12.13	44.17	488
CR(E) 20-6	15	3	•	27.17	10.22	8.67	43.75	10.62	7.33	43.48	402	13.39	12.13	45.95	491
CR 20-7	20	3	•	28.94	10.22	8.67	45.52	11.50	8.92	48.63	438	-	-	-	-
CR(E) 20-8	20	3	-	30.71	10.22	8.67	47.29	11.50	8.92	50.40	442	13.39	12.13	49.49	508
CR(E) 20-10	25	3	-	33.62	12.94	11.52	53.44	11.50	8.94	54.43	496	13.39	12.13	56.34	543

All dimensions in inches unless otherwise noted.

*Oval flanged pump B1 and B1+B2 dimension is equal to ANSI flanged pumps and weight is approximately 3 lbs. less.

• Available.

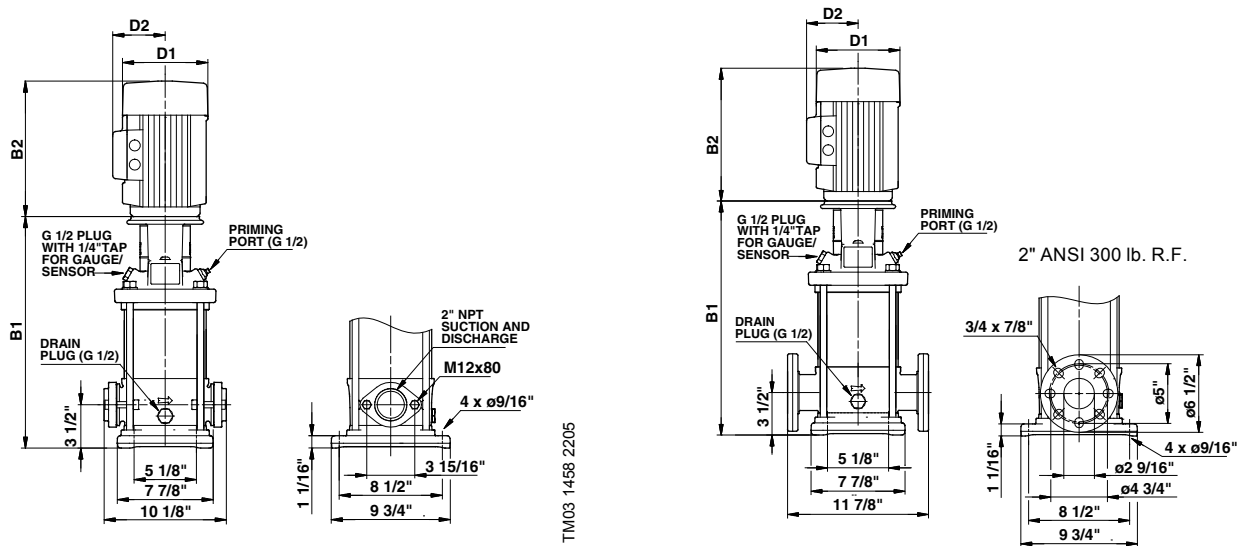

TM03 1458 2205

TM03 1459 2205

Pump type	P2 [hp]	Ph.	ANSI dimensions [inch]									Ship Wt. [lbs.]	ANSI dimensions [inch]			
			Oval*	B1	TEFC			ODP			MLE			Ship Wt. [lbs.]		
					D1	D2	B1+B2	D1	D2	B1+B2	D1		D2		B1+B2	
CRI(E) 20-1	3	1	•	17.13	8.60	6.87	31.78	-	-	-	174	-	-	-	-	
		3	•	17.13	7.01	4.33	30.36	-	-	-	145	7.01	6.57	29.93	152	
CRI(E) 20-2	5	1	•	17.13	10.62	7.46	32.65	-	-	-	198	-	-	-	-	
		3	•	17.13	8.66	5.28	32.64	-	-	-	195	8.66	7.40	29.93	185	
CRI(E) 20-3	7 1/2	1	•	19.21	10.22	7.62	34.74	-	-	-	216	-	-	-	-	
		3	•	19.21	8.66	5.28	34.72	-	-	-	203	8.66	7.40	19.21	216	
CRI(E) 20-4	10	1	•	20.98	10.23	10.30	37.05	-	-	-	331	-	-	-	-	
		3	•	20.98	8.66	5.28	36.49	-	-	-	205	10.24	8.39	34.29	223	
CRI(E) 20-5	15	3	•	25.28	10.22	8.67	41.86	10.62	7.33	41.59	391	13.39	12.13	44.06	480	
CRI(E) 20-6	15	3	•	27.05	10.22	8.67	43.63	10.62	7.33	43.36	396	13.39	12.13	45.83	484	
CRI 20-7	20	3	•	28.82	10.22	8.67	45.40	11.50	8.92	48.51	431	-	-	-	-	
CRI(E) 20-8	20	3	-	30.59	10.22	8.67	47.17	11.50	8.92	50.28	435	13.39	12.13	49.37	501	
CRI(E) 20-10	25	3	-	33.50	12.94	11.52	53.32	11.50	8.94	54.31	490	13.39	12.13	56.22	537	

All dimensions in inches unless otherwise noted.

*Oval flanged pump B1 and B1+B2 dimension is equal to ANSI flanged pumps and weight is approximately 7 lbs. less.

• Available.

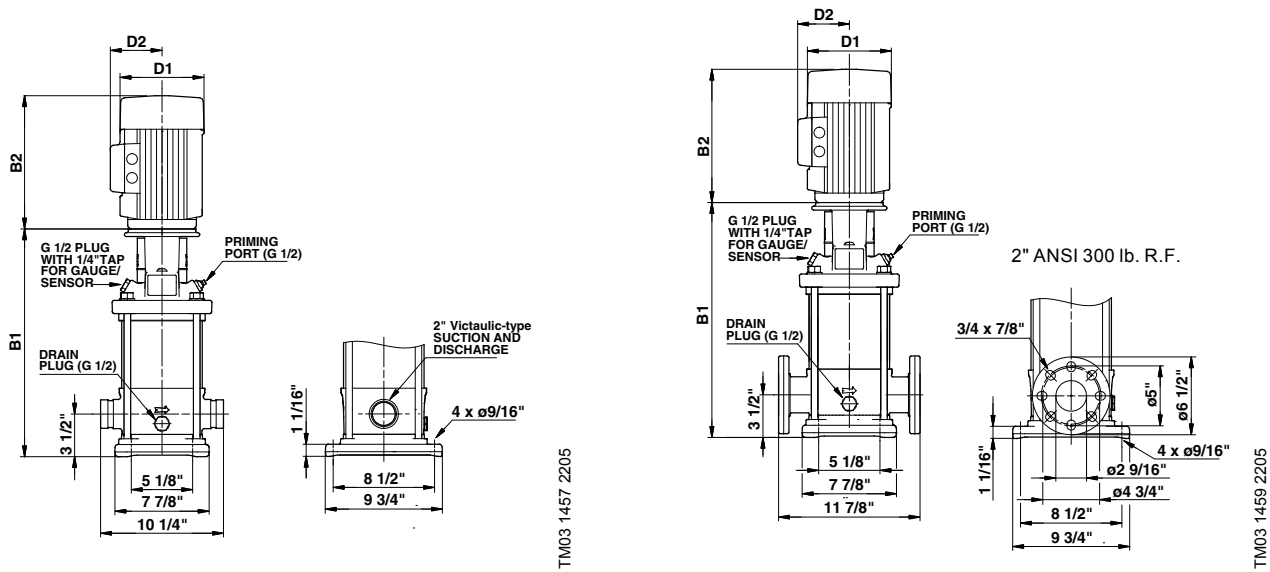

Pump type	P2 [hp]	Ph.	Dimensions [inch]									Ship Wt. [lbs.]	Dimensions [inch]			Ship Wt. [lbs.]
			PJE*	B1	TEFC			ODP			MLE					
					D1	D2	B1+B2	D1	D2	B1+B2	D1		D2	B1+B2		
CRN(E) 20-1	3	1	•	17.13	8.60	6.87	31.78	-	-	-	174	-	-	-	-	
			•	17.13	7.01	4.33	30.36	-	-	-	145	7.01	6.57	29.93	154	
CRN(E) 20-2	5	1	•	17.13	10.62	7.46	32.65	-	-	-	198	-	-	-	-	
			•	17.13	8.66	5.28	32.64	-	-	-	195	8.66	7.40	29.93	185	
CRN(E) 20-3	7 1/2	1	•	19.21	10.22	7.62	34.74	-	-	-	216	-	-	-	-	
			•	19.21	8.66	5.28	34.72	-	-	-	203	8.66	7.40	19.21	216	
CRN(E) 20-4	10	1	•	20.98	10.23	10.30	37.05	-	-	-	331	-	-	-	-	
			•	20.98	8.66	5.28	36.49	-	-	-	207	10.24	8.39	34.29	225	
CRN(E) 20-5	15	3	•	25.28	10.22	8.67	41.86	10.62	7.33	41.59	394	13.39	12.13	44.06	480	
CRN(E) 20-6	15	3	•	27.05	10.22	8.67	43.63	10.62	7.33	43.36	396	13.39	12.13	45.83	484	
CRN 20-7	20	3	•	28.82	10.22	8.67	45.40	11.50	8.92	48.51	431	-	-	-	-	
CRN(E) 20-8	20	3	•	30.59	10.22	8.67	47.17	11.50	8.92	50.28	435	13.39	12.13	49.37	501	
CRN(E) 20-10	25	3	•	33.50	12.94	11.52	53.32	11.50	8.94	54.31	490	13.39	12.13	56.22	537	

All dimensions in inches unless otherwise noted.

*PJE flanged pump B1 and B1+B2 dimension is equal to ANSI flanged pumps and weight is approximately 9 lbs. less.

• Available.