



Product Range

Industry
Machines & Tools
February 2006
Export



Product Range Piping Systems

Machines for Processing Plastic - Pipes

		Page
	IR 63 Fusion Jointing Machine	5
	IR 225 Fusion Jointing Machine	9
	IR 315 Fusion Jointing Machine	12
	BCF plus Fusion Jointing Machine	14
	Hand Fusion Tools	23
	Standard Fusion Machine	28
	Drainage Fusion Maschine	47
	Pipe Cutters	49
	Electrofusion Units and Accessories	57
	Accessories for job sites	77

Product Range

IR 63 / 225 / 315



IR-63 Plus® Fusion Jointing Machine and Accessories



IR-63 Plus® Fully-Equipped Machine

Fully-equipped fusion jointing machine for welding SYGEF® Standard, SYGEF® Plus, DEKAPROP®, PROGEF® Natural, PROGEF® Plus, PE 100 in dimensions d 20-63 mm with integrated remote welding unit.

Supply:

1-phase AC (50/60 Hz) 230 V L/N/PE

Delivery includes:

- Machine housing complete (1 pcs.)
- Heater assembly (1 pcs.)
- Remote weld device (1 pcs.)
- Facing tool (1 pcs.)
- Transport box (1 pcs.)
- Pipe stop (1 pcs.)
- Clamping inserts d 20-63 mm (8 pcs. per dimension)
- End caps PE d 20-63 mm (4 pcs. per dimension)
- Power supply cable 230 V (1 pcs.)
- Extension cable for remote weld device (1 pcs.)
- Extension cable for heater (1 pcs.)
- Extension cable for facing tool (1 pcs.)
- Cleaning brush No. 8 (1 pcs.)
- Hexagon key 3 mm (1 pcs.)
- Hexagon key 4 mm (1 pcs.)
- Heater protection shield (1 pcs.)
- Clamping unit extension (8 pcs.)
- Socket wrench (facing blades) (1 pcs.)
- Screw driver, Size 0 (1 pcs.)
- HP-Accessory Tray (1 pcs.)
- Manual (1 pcs.)

d-d [mm]	Code	kg	
20 - 63	790 131 005	52.000	

PF 2 43 412



Clamping inserts

- The clamping inserts are different for each dimension. They are used to clamp and position the pipe components.

d [mm]	Code	kg	Pieces	
20	790 131 038	0.090	1	
25	790 131 039	0.090	1	
32	790 131 040	0.083	1	
40	790 131 041	0.075	1	
50	790 131 042	0.100	1	
63	790 131 043	0.040	1	

PF 2 43 412



Set of facing knives

- A set includes two facing knives. Each facing knife has four blades. The blade may be turned three times before it must be replaced.

d-d [mm]	Code	kg	Pieces	
20 - 63	790 131 045	0.020	2	

PF 2 43 412



Set of end caps

- A set includes 4 end caps. The end caps are different for each dimension. The ends of the pipe **must** be closed. The caps prevent heat loss due to airflow in the fusion zone and guarantee optimum fusion results of the pipe components.

d [mm]	Code	kg	Pieces
20	790 131 030	0.010	4
25	790 131 031	0.010	4
32	790 131 032	0.015	4
40	790 131 033	0.025	4
50	790 131 034	0.055	4
63	790 131 035	0.035	4

PF 2 43 412



Pipe stop

- The pipe stop defines the allowance when the pipes are clamped into position.

d-d [mm]	Code	kg	Pieces
20 - 63	790 131 046	0.430	1

PF 2 43 412



Extension cable for clamping slide

- The extension cable enables the fusion e. g. under the ceiling.

d-d [mm]	Code	kg	Pieces
20 - 63	790 131 047	0.700	1

PF 2 43 412



Extension cable for facing tool

- The extension cable enables the fusion e. g. under the ceiling.

d-d [mm]	Code	kg	Pieces
20 - 63	790 131 048	0.438	1

PF 2 43 412



Extension cable for heater

- The extension cable enables the fusion e. g. under the ceiling.

d-d [mm]	Code	kg	Pieces
20 - 63	790 131 049	0.700	1

PF 2 43 412



HP-Accessory Tray

- For transport and practical storage of all accessory parts of the IR-63 Plus® fusion machine in clean rooms.
- In case of repeat order for IR-63 Plus® included in delivery

Code	kg	Pieces
790 131 056	3.130	1

PF 2 43 412



PF 2 43 412

Heater protection shield

- Protects the heater from plastic chips during the facing process.

Code	kg	Pieces	
790 131 051	0.205	1	



IR-63 Plus[®] Modification Kit

- In order to give our existing IR-customers the full benefit of the advantages of the IR Plus[®] we offer a modification kit which enables a reconstruction of all existing IR machines up to the latest IR Plus[®] technology.
- **The modification kit contains basically the following components:**
 - Complete Electronic unit
 - Ambient temperature sensor
 - New display
 - As additional option - on request - a update with moveable clamping units is possible.
 - The upgrade of the IR Plus[®] components will be executed by the George Fischer service stations in the USA/Tustin and SCS in Singen.

Code	kg	Pieces	
790 131 063	5.800	1	

PF 2 43 412

IR-225 Plus® Fusion Jointing Machine and Accessories



IR-225 Plus® Fully-Equipped Machine with HP Working Table (HP = High Purity)

Fully-equipped fusion jointing machine for welding SYGEF® Standard, SYGEF® Plus, DEKAPROP®, PROGEF® Natural, PROGEF® Plus, PE 100 in dimensions d 63-225 mm.

Supply:

1-phase AC (50/60 Hz) 230 V L/N/PE or 3-phase AC (50/60 Hz) 400 V/230 V L1/L2/L3/N/PE

Delivery includes:

- Machine base (1 pcs.)
- Heater assembly (1 pcs.)
- Facing tool (1 pcs.)
- Working table, HP (1 pcs.)
- Movable clamping units (1 pcs.)
- Clamping inserts d 63-225 mm (8 pcs. per dimension)
- End caps PE d 63-225 mm (4 pcs. per dimension)
- Transportation lock (1 pcs.)
- Pipe stop (1 pcs.)
- Hexagon key 5 mm (1 pcs.)
- Hexagon key 6 mm (1 pcs.)
- Combination ring /open-jaw wrench 13 mm (1 pcs.)
- Cleaning brush (1 pcs.)
- Connecting cable 400 V - 230 V (1 pcs.)
- Ball for lever (1 pcs.)
- Manual (1 pcs.)

d-d [mm]	Code	kg	
63 - 225	790 133 009	453.000	

PF 2 43 414

Clamping inserts

- The clamping inserts are different for each dimension. They are used to clamp and position the pipe components.



d [mm]	Code	kg	Pieces	
63	790 133 026	0.700	1	
75	790 133 027	0.400	1	
90	790 133 028	0.400	1	
110	790 133 029	0.685	1	
125	790 133 030	0.500	1	
140	790 133 031	0.600	1	
160	790 133 032	0.600	1	
200	790 133 033	0.700	1	
225	790 133 034	0.270	1	

PF 2 43 414



Set of end caps

- A set includes 4 end caps. The end caps are different for each dimension. The ends of the pipe **must** be closed. The caps prevent heat loss due to airflow in the fusion zone and guarantee optimum fusion results of the pipe components.

d [mm]	Code	kg	Pieces
63	790 131 035	0.035	4
75	790 133 036	0.090	4
90	790 133 037	0.110	4
110	790 133 038	0.180	4
125	790 133 039	0.150	4
140	790 133 040	0.180	4
160	790 133 041	0.290	4
200	790 133 042	0.460	4
225	790 133 043	0.400	4

PF 2 43 414



Movable clamping unit - left

- The movable, external clamping unit ensure high operating convenience. Short pipe pieces can be clamped on both sides.
- Included in the delivery when a new IR-225 Plus[®] is ordered.
- Previous IR 225 fusion jointing machines can be upgraded.

d-d [mm]	Code	kg	Pieces
63 - 225	790 133 061	10.700	1

PF 2 43 414



Movable clamping unit - right

- The movable, external clamping unit ensure high operating convenience. Short pipe pieces can be clamped on both sides.
- Included in the delivery when a new IR-225 Plus[®] is ordered.
- Previous IR 225 fusion jointing machines can be upgraded.

d-d [mm]	Code	kg	Pieces
63 - 225	790 133 062	10.200	1

PF 2 43 414



HP-Working table including transportation cover

- Multifunction working table for the IR-225 Plus[®] fusion jointing machine with two integrated drawer. Especially for the use in clean room environment. The working table is made of steel with a stainless steel table.

Code	kg	Pieces
790 133 021	220.000	1

PF 2 43 414



Set of facing knives

- A set includes two facing knives. Each facing knife has four blades. The blade may be turned three times before it must be replaced.

d-d [mm]	Code	kg	Pieces
63 - 225	790 133 046	0.120	2

PF 2 43 414



PF 2 43 414

Pipe stop

- The pipe stop defines the allowance when the pipes are clamped into position.

d-d [mm]	Code	kg	Pieces
63 - 225	790 133 047	0.150	1



IR-225 Plus[®] Modification Kit

- In order to give our existing IR-customers the full benefit of the advantages of the IR Plus[®] we offer a modification kit which enables a reconstruction of all existing IR machines up to the latest IR Plus[®] technology.
- **The modification kit contains basically the following components:**
 - Complete Electronic unit
 - Ambient temperature sensor
 - Infrared sensor
 - New display
 - Cooling fan
 - Cooling fan support
- The upgrade of the IR Plus[®] components will be executed by the George Fischer service stations in the USA/Tustin and SCS in Singen.

Code	kg	Pieces
790 133 063	14.000	1

PF 2 43 414

IR-315 Plus[®] Fusion Jointing Machine



IR-315 Plus[®] Fully-Equipped Machine with HP Working Table (HP = High Purity)

Model:

- Fully-equipped fusion jointing machine for welding SYGEF[®] Standard, SYGEF[®] Plus in dimensions d 250-315.
- **Only a rental pool machine**

d-d [mm]		Code	
250 - 315	On request	-	

Accessories for the IR plastic fusion jointing machines



IR Plus® Win Weld

- The PC data transfer software makes it possible to manage and evaluate easily the recorded fusion data as required.
- **incl. Recordcard**

PF 2 43 278

	Code	kg	Pieces	
WIN 2000/XP	790 131 471	0.245	1	
WIN 95/98/Me	790 131 472	0.220	1	



IR Plus® Recordcard

- Fusion data from the machine can be stored on an exchangeable protocol card (record card) with a storage capacity of approx. 900 fusion protocols. It allows a paperless documentation.

PF 2 43 412

Code	kg	Pieces	
790 131 473	0.065	1	



Interface-box for Label Printer

- The interface-box is necessary to use a label printer for weld documentation in relation to IR 63¹⁾ and IR 225¹⁾ fusion machines as well as for the SYGEF® HP BCF²⁾ fusion machine from George Fischer.

¹⁾ The interface-box is not required for IR Plus® fusion machines, because a serial/parallel port is included.

²⁾ From machine number 122 450 501 on and modified BCF fusion machines

PF 2 43 412

Code	kg	Pieces	
790 131 026	1.200	1	

Product Range

BCF

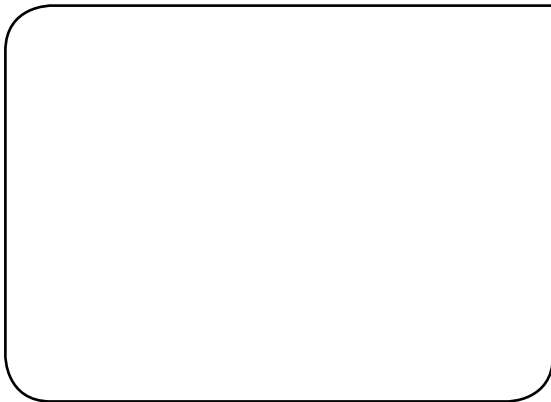

BCF[®] Plus Plastic Fusion Jointing Machine



BCF[®] Plus fully equipped machine d 20 - 63 mm

Fully-equipped machine for bead and crevice free jointing of SYGEF[®] Standard, SYGEF[®] Plus, PROGEF[®] Natural of the dimensions d 20-63 mm with integrated remote welding unit.

Supply:

1-phase AC (50/60 Hz) 115 / 230 V L/N/PE

Delivery includes:

- Machine housing (1 pcs.) incl. remote welding unit (1 pcs.)
- Transport box (1 pcs.)
- HP working table (1 pcs.)
- Heating stations d 20-63 mm (6 pcs.)
- Clamping units small (2 pcs.) with clamping inserts d 20-63 mm (24 pcs.)
- Facing tool small (1 pcs.) with facing inserts d 20-63 mm (6 pcs.)
- Facing tool support (1 pcs.)
- Hose box (1 pcs.) incl. air hose (1 pcs.)
- Supporting tools small d 20-63 mm (2 pcs.)
- BReT (1 pcs.)
- Hose cutter (1 pcs.)
- Air hose reducer (6-4 mm) (1 pcs.), air hose socket (4-4 mm) (1 pcs.)
- Extension cable (1 pcs.)
- Manual (1 pcs.)

d-d [mm]	Code	kg	
20 - 63	790 121 002	153.000	

PF 2 43 654



BCF[®] Plus fully-equipped machine d 20 -110 mm

Fully-equipped machine for bead and crevice free jointing of SYGEF[®] Standard, SYGEF[®] Plus, PROGEF[®] Natural of the dimensions d 20-110 mm with integrated remote welding unit.

Supply:

1-phase AC (50/60 Hz) 115 / 230 V L/N/PE

Delivery includes:

- Machine housing (1 pcs.) incl. remote welding unit (1 pcs.)
- Transport box (1 pcs.)
- HP working table (1 pcs.)
- Heating stations d 20-110 mm (9 pcs.)
- Clamping units small (2 pcs.) with clamping inserts d 20-63 mm (24 pcs.)
- Clamping units big (2 pcs.) with clamping inserts d 75-110 mm (12 pcs.)
- Adapter for clamping unit d 75-110 mm (2 pcs.)
- Facing tool small (1 pcs.) with facing inserts d 20-63 mm (6 pcs.)
- Facing tool big (1 pcs.) with facing inserts d 75-110 mm (3 pcs.)
- Facing tool support (1 pcs.)
- Hose box (1 pcs.) incl. air hose (1 pcs.)
- Supporting tools small d 20-63 mm (2 pcs.)
- Supporting tools big d 75-110 mm (2 pcs.)
- BReT (1 pcs.)
- Hose cutter (1 pcs.)
- Air hose reducer (6-4 mm) (1 pcs.), air hose socket (4-4 mm) (1 pcs.)
- Extension cable (1 pcs.)
- Manual (1 pcs.)

d-d [mm]	Code	kg	
20 - 110	790 121 001	188.000	

PF 2 43 654



BCF[®] Plus Heating stations

d [mm]	Code	kg	Pieces	
20	790 121 111	0.001	1	
25	790 121 112	0.001	1	
32	790 121 113	0.001	1	
40	790 121 114	0.001	1	
50	790 121 115	2.400	1	
63	790 121 116	0.001	1	
75	790 121 117	3.600	1	
90	790 121 118	3.600	1	
110	790 121 119	3.500	1	

PF 2 43 654



BCF[®] Bladder for SYGEF[®] PVDF

- Only suitable for welding SYGEF[®] PVDF and not for PROGREF[®] Natural. **Silver bladder head!**

d [mm]	Code	kg	Pieces	
20	790 122 041	0.014	1	
25	790 122 042	0.029	1	
32	790 122 043	0.037	1	
40	790 122 044	0.055	1	
50	790 122 045	0.108	1	
63	790 122 046	0.152	1	
75	790 121 047	0.152	1	
90	790 121 048	0.204	1	
110	790 121 049	0.428	1	

PF 2 43 654



BCF[®] Plus Bladder

- Only suitable for welding PROGREF[®] Natural). **Blue bladder head** (except d 75 -110mm)!

d [mm]	Code	kg	Pieces
20	790 122 091	0.038	1
25	790 122 092	0.044	1
32	790 122 093	0.062	1
40	790 122 094	0.082	1
50	790 122 095	0.131	1
63	790 122 096	0.168	1
75	790 121 047	0.152	1
90	790 121 048	0.204	1
110	790 121 049	0.428	1

PF 2 43 410



BCF[®] Plus facing tool

- Inclusive crank handle, mounting material and clamping inserts. Suitable for SYGEF[®] PVDF as well as PROGREF[®] Natural.

d-d [mm]	Code	kg	Pieces
20 - 63	790 121 052	1.400	1
75 - 110	790 121 053	3.000	1

PF 2 43 654



BCF[®] Plus clamping inserts for the facing tool

- These dimension-specific parts are inserted into the facing tool, in order to be able to face the end of the pipes smoothly and parallel.

d [mm]	Code	kg	Pieces
20	790 121 061	0.160	1
25	790 121 062	0.150	1
32	790 121 063	0.132	1
40	790 121 064	0.125	1
50	790 121 065	0.100	1
63	790 121 066	0.050	1
75	790 121 067	0.300	1
90	790 121 068	0.200	1
110	790 121 069	0.090	1

PF 2 43 654



BCF[®] Plus facing tool mounting plate

- To fix the facing tool on the workbench.

d-d [mm]	Code	kg	Pieces
20 - 110	790 121 055	1.200	1

PF 2 43 654



BCF[®] Plus clamping units

- The clamping units are adjustable, so that all types of pipes and fittings can be clamped.

d-d [mm]	Code	kg	Pieces
20 - 63	790 121 034	0.900	1
75 - 110	790 121 035		1

PF 2 43 654



BCF® Plus adapter for clamping unit d 75-110 mm

- The adapter makes it possible, to insert clamping inserts with d 20-63 mm in clamping units with d 75-110 mm to be able to clamp pipes and fittings with d 20-63 mm with these clamping units.

d-d [mm]	Code	kg	Pieces
75 - 110	790 121 038	0.250	1

PF 2 43 654



BCF® Plus clamping inserts

- The clamping inserts are suitable for the clamping units of the BCF®Plus machine. They are used to clamp the piping components.
- **No clamping inserts are needed for d 110 mm!**

d [mm]	Code	kg	Pieces
20	790 131 038	0.090	1
25	790 131 039	0.090	1
32	790 131 040	0.083	1
40	790 131 041	0.075	1
50	790 131 042	0.100	1
63	790 131 043	0.040	1
75	790 121 036	0.143	1
90	790 121 037	0.095	1

PF 2 43 654



BCF® Plus hose box

- For the clean and professional storage of the air hose.

Code	kg	Pieces
790 121 077	0.001	1

PF 2 43 654



BCF® Plus hose

- Connection hose for the BCF®Plus bladder.

Code	kg	Length [mm]
790 122 087	0.123	16

PF 2 43 410



BCF® Plus supporting tool

- Helpful to fix 45°- angle components.

d-d [mm]	Code	kg	Pieces
20 - 63	790 121 072	0.542	1
75 - 110	790 121 073	0.900	1

PF 2 43 654



BCF® Plus bladder/ hose remove tool (BReT)

- Helpful to remove bladders easily.

Code	kg	Pieces
790 121 075	0.079	1

PF 2 43 654



BCF[®] Plus extension cable

- The extension cable enable the fusion e. g. under the ceiling.

PF 2 43 654

Code	kg	Length [mm]	
790 121 010	2.000	8	

Accessories for the BCF[®]Plus plastic fusion jointing machine

Hose cutter



PF 2 43 410

d-d [mm]	Code	kg	Pieces
4 - 6	790 122 106	0.029	1

Reducer for compressed air hose



PF 2 43 460

d-d [mm]	Code	kg	Pieces
6 - 4	790 122 978	0.002	1

Socket for compressed air hose



PF 2 43 410

Code	kg	Pieces
790 122 104	0.006	1



BCF[®] Plus Win Weld

- The PC data transfer software makes it possible to manage and evaluate easily the recorded fusion data as required.
- **incl. Recordcard**

PF 2 43 278

	Code	kg	Pieces
WIN 2000/XP	790 121 471	0.245	1
WIN 95/98/Me/NT	790 121 472	0.220	1



BCF[®] Plus Recordcard

- Fusion data from the BCF[®] Plus- machine can be stored on an exchangeable protocol card (record card) with a storage capacity of approx. 900 fusion protocols. It allows a paperless documentation.

PF 2 43 412

Code	kg
790 121 473	0.065

Accessories for the IR-63 Plus[®], IR-225 Plus[®], IR-315 Plus[®] and BFC[®] Plus fusion machines



PF 2 43 412

Label Printer TLP-2742

- The thermotransfer printer TLP-2742 from Eltron International is, as a result of its compactness and ergonomic design, ideal for use on job sites. Supply includes a thermal printer ribbon, thermal transfer labels and a serial as well as a parallel interfa
- **Remarks:** We suggest, regarding service and warranty matters, to purchase directly from the local Eltron Representative. George Fischer can provide a list of world-wide addresses of the Eltron representatives on request.

Code	kg	Pieces	
790 131 027	3.100	1	



PF 2 43 412

Thermal Printer Ribbon for TLP-2742

- The thermal transfer ribbon is specially suited for printing polyester labels.

Code	kg	Pieces	
790 131 029	0.120	1	



PF 2 43 412

Thermal Transfer Labels

- The labels are made of white polyester. The printing, as well as the labels themselves, are resistant against:
 - UV resistant
 - Temperatures up to 140 °C (284 °F)
 - Up to 95% humidity
 - Cleaning agents (Isopropylalcohol etc.)
- Two identical labels are printed for each weld. Each roll contains 2500 labels.
- Label size: 38 x 19 mm
- Specification information available on request from George Fischer.

Code	kg	Pieces	
790 131 028	0.420	1	



PF 2 43 410

Power supply lead

Performance	Code	kg	Pieces	
230V	790 122 246	0.301	1	
115V	790 122 248	0.188	1	

Plastic Cleaning Agents

Degreasing Tissues

- For degreasing the PE pipe surface prior to fusion.

Type	Code	kg	Description
small	799 496 010	0.005	For pipes up to d 63mm
large	799 496 011	0.010	For pipes up to d 225mm

PF 2 51 305

Tangit KS Cleaning Tissues

- Special cleaning agent for plastic fusion connections with PP, PE, PVDF and PB.
- Scope of delivery: Standard packing 8 boxes with 100 tissues each

Code	kg
799 298 024	3.245

PF 2 28 473

Cleaning tissue KO-TON-R

- This cleaning tissue is suitable for the cleaning of the welding zone of piping components, because it is lint free and clean room checked.

1) Minimum order quantity 50 pieces

Code	kg
790 122 085	0.004

KS Tangit Cleaner

F

- Special cleaning agent for plastic fusion connections with PP, PE, PVDF and PB.

Code	kg
799 298 023	0.890

PF 2 28 473

Product Range

Hand tools

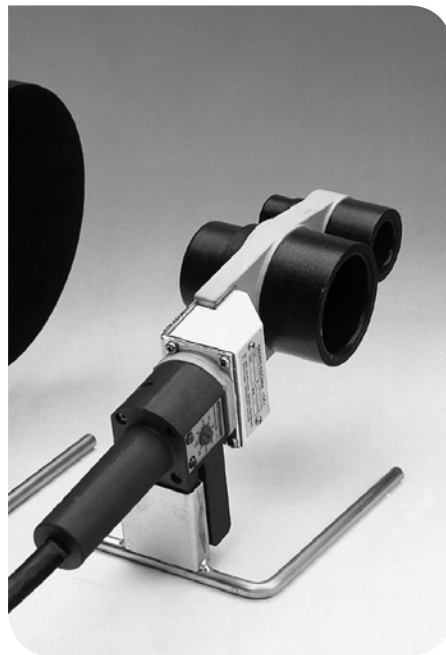

Manual fusion tools

SSE Butt fusion tool



- All devices are equipped with on/off switch, mains control and control lamp for heating intervals
- Choice of electronic or thermostatic temperature control
- Heating element diameter 120 mm, 200 mm and 300 mm
- Pick up for floor stand or table clamp
- High-quality, non-stick PTFE-coating with long service life
- Monitoring and setting of heating element temperature
- High temperature accuracy over the entire heating surface
- T = thermostatic
- E = electronic

d [mm]	Type	Performance	Code	kg	
110	SSE 120	230 V/400 W T	790 105 051	2.300	
110	SSE 120	230 V/400 W E	790 105 058	2.400	
110	SSE 120	115 V/400 W T	790 105 136	2.300	
110	SSE 120	115 V/400 W E	790 105 141	2.400	
180	SSE 200	230 V/800 W T	790 105 052	3.000	
180	SSE 200	230 V/800 W E	790 105 059	3.000	
180	SSE 200	115 V/800 W T	790 105 137	3.000	
180	SSE 200	115 V/800 W E	790 105 142	3.000	
280	SSE 300	230 V/1500 W T	790 105 053	5.540	
280	SSE 300	230 V/1500 W E	790 105 060	5.640	
280	SSE 300	115 V/1500 W T	790 105 138	5.540	
280	SSE 300	115 V/1500 W E	790 105 143	5.640	

PF 3 25 117

SSE 200 -Set- Butt fusion tool



- All devices are equipped with on/off switch, mains control and control lamp for heating intervals
- Choice of electronic or thermostatic temperature control
- Pick up for floor stand or table clamp
- High-quality, non-stick PTFE-coating with long service life
- Monitoring and setting of heating element temperature
- High temperature accuracy over the entire heating surface
- Available as a complete set in a practical metal case
- Heating element-diameter 200 mm
- Table clamp
- T = thermostatic
- E = electronic

d [mm]	Performance	Code	kg	
180	230 V/800 W T	790 105 054	7.815	
180	230 V/800 W E	790 105 061	8.800	
180	115 V/800 W T	790 105 139	7.400	
180	115 V/800 W E	790 105 144	7.400	

PF 3 25 122



SSE 300 -Set- Butt fusion tool

- All devices are equipped with on/off switch, mains control and control lamp for heating intervals
- Choice of electronic or thermostatic temperature control
- Pick up for floor stand or table clamp
- High-quality, non-stick PTFE-coating with long service life
- Monitoring and setting of heating element temperature
- High temperature accuracy over the entire heating surface
- Available as a complete set in a practical metal case
- Heating element-diameter 300 mm
- Table clamp
- T = thermostatic
- E = electronic

d [mm]	Performance	Code	kg
280	230 V/1500 W T	790 105 055	11.725
280	230 V/1500 W E	790 105 062	11.000
280	115 V/1500 W T	790 105 140	11.000
280	115 V/1500 W E	790 105 145	11.000

PF 3 25 122



MSE 63/MSE 110 Socket fusion tools

- For fusion jointing of PP, PE and PVDF pipes and fittings
- Size range d 16-110 mm
- All devices are equipped with on/off switch, mains control and control lamp for heating intervals
- Choice of electronic or thermostatic temperature control
- Support for heating bushes and spigots of d 16 to 63 mm (110 mm)
- Pick up for floor stand or table clamp
- High-quality, non-stick PTFE-coating with long service life
- Monitoring and setting of heating element temperature
- High temperature accuracy over the entire heating surface
- T = thermostatic
- E = electronic

d-d [mm]	Type	Performance	Code	kg
16 - 63	MSE 63	230 V/800 W T	790 105 081	1.760
16 - 63	MSE 63	230 V/800 W E	790 105 082	2.000
16 - 63	MSE 63	115 V/800 W T	790 105 096	2.075
16 - 63	MSE 63	115 V/800 W E	790 105 097	2.145
16 - 110	MSE 110	230 V/1500 W T	790 105 083	3.550
16 - 110	MSE 110	230 V/1500 W E	790 105 084	3.200
16 - 110	MSE 110	115 V/1500 W T	790 105 126	3.200
16 - 110	MSE 110	115 V/1500 W E	790 105 127	3.200

PF 3 25 117

Tool set for MSE 63/110

- Including allen screws and key

Code	kg
790 105 065	0.265

PF 3 25 117



MSE 63/MSE 110 - Set - Socket fusion tools

- For fusion jointing of PP, PE and PVDF pipes and fittings
- Size range d 16-110 mm
- All devices are equipped with on/off switch, mains control and control lamp for heating intervals
- Choice of electronic or thermostatic temperature control
- Support for heating bushes and spigots of d 16 to 63 mm (110 mm)
- Pick up for floor stand or table clamp
- High-quality, non-stick PTFE-coating with long service life
- Monitoring and setting of heating element temperature
- High temperature accuracy over the entire heating surface
- Heating bushes and spigots
- Available as a complete set in a practical metal case
- Table clamp
- Floor stand for MSE 63
- Allen screws and key
- T = thermostatic
- E = electronic

d-d [mm]	Type	Performance	Code	kg	
16 - 63	MSE 63	230 V/800 T	790 105 085	8.600	
16 - 63	MSE 63	230 V/800 E	790 105 086	10.180	
16 - 63	MSE 63	115 V/800 T	790 105 098	8.600	
16 - 63	MSE 63	115 V/800 E	790 105 099	8.600	
16 - 110	MSE 110	230 V/1500 T	790 105 087	17.700	
16 - 110	MSE 110	230 V/1500 E	790 105 088	17.680	
16 - 110	MSE 110	115 V/1500 T	790 105 128	15.600	
16 - 110	MSE 110	115 V/1500 E	790 105 129	15.600	

PF 3 25 122

Accessories/Wearing parts for manual fusion tools

Metal case



PF 3 25 117

- For butt and socket fusion hand tools

Article	Code	kg
SSE 200	790 105 056	3.900
SSE 300	790 105 057	4.700
MSE 63	790 105 089	4.000
MSE 110	790 105 090	7.000

Floor stand for manual fusion tools SSE/MSE



PF 3 25 117

Code	kg
790 105 063	0.300

Table clamp for SSE/MSE



PF 3 25 117

Code	kg
790 109 315	0.700

Heating spigots and bushes



PF 3 25 117

- Aluminium, PTFE coated
- Type B
- Always delivered in pairs (also usable for SG 110, not for SG 160)

d [mm]	Code	kg
16	799 300 155	0.070
20	799 300 156	0.080
25	799 300 157	0.110
32	799 300 158	0.140
40	799 300 159	0.230
50	799 300 160	0.335
63	799 300 161	0.660
75	799 300 162	0.965
90	799 300 163	1.440
110	799 300 164	2.210

Product Range

Standard Fusion Machines

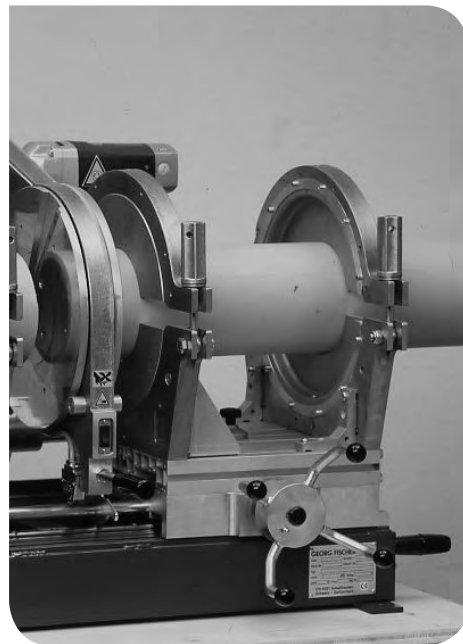
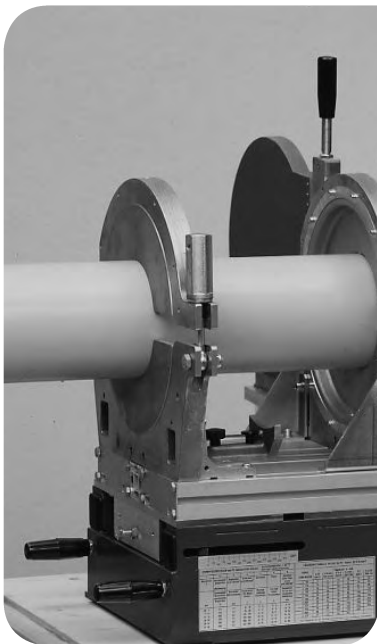

SG 110 Socket fusion machine

For fusion jointing of PP, PE, PB and PVDF pipes and fittings



- Portable heating element - socket fusion machine for use in the workshop and on job sites.
- Dimension d 20 - 110 mm
- **Base machine**
- Compact, sturdy design, distortion-free machine bed
- Handwheel with torque locking mechanism for the slide movement
- **Heater**
- With electronic temperature control
- High temperature accuracy over the entire heating surface
- **Additional standard equipment on the basic model**
- Universal, left and right prismatic clamping devices, complete, for clamping pipe and fittings. Additional set of prismatic clamping devices for outer clamping of pipes available as an option.
- Depth stop
- V-shaped pipe support d 20 - 110 mm
- Back stop
- Machine specific tool set
- Timer to clock fusion times

d-d [mm]	Performance	Code	kg	
20 - 110	230 V/1200 W	790 310 001	65.000	
20 - 110	115 V/1200 W	790 310 003	64.000	

PF 3 25 134



Heating spigots and bushes

- For socket fusion systems in PP, PE and PVDF
- Always delivered in pairs (also usable for SG 110, not for SG 160)
- Type B

d [mm]	Code	kg	
20	799 300 156	0.080	
25	799 300 157	0.110	
32	799 300 158	0.140	
40	799 300 159	0.230	
50	799 300 160	0.335	
63	799 300 161	0.660	
75	799 300 162	0.965	
90	799 300 163	1.440	
110	799 300 164	2.210	

PF 3 25 117



Manual pipe peeling tool

- For socket fusion systems in PP, PE and PVDF

d [mm]	Code	kg	
20	799 300 260	0.059	
25	799 300 270	0.074	
32	799 300 280	0.100	
40	799 300 290	0.259	
50	799 300 300	0.299	
63	799 300 310	0.513	
75	799 300 320	0.750	
90	799 300 330	1.070	
110	799 300 340	1.350	

Chamfering tool

PF 3 10 590

d-d [mm]	Code	kg
40 - 200	790 309 001	1.600
50 - 315	790 309 002	3.170



Universal prismatic clamping device, complete

- For correct clamping of long pipes, fittings
- 1 set = 2 pieces (1 back and 1 front prismatic clamping device) for mounting on left or right side, as well as for inner and outer mounting

PF 3 25 134

d-d [mm]	Code	kg
20 - 110	790 310 011	3.300



Backstop, complete

- Prevents the components from slipping out of the clamping device during fusion.

PF 3 25 117

d-d [mm]	Code	kg
20 - 110	790 310 012	0.600



V-shaped pipe support, complete

PF 3 25 117

d-d [mm]	Code	kg
20 - 110	790 310 013	0.700



Heating element

- E = electronic
- T = thermostatic

PF 3 25 117

d-d [mm]	Performance	Code	kg
20 - 110	230 V/1200 W E	790 310 014	2.400
20 - 110	230 V/1200 W T	790 310 015	2.400
20 - 110	115 V/1200 W E	790 310 016	2.400
20 - 110	115 V/1200 W T	790 310 017	2.400



PF 3 25 117

Special transport crate

Code	kg
790 310 099	45.000



PF 3 25 117

1 set face chucks

- For back and front prismatic clamping device (set of 2 pieces)

d-d [mm]	Code	kg
20 - 110	790 310 018	1.100

PSO 701 Butt fusion machine

For fusion jointing of PP and PE pipes and range d 40 - 160mm



- Professional butt fusion machine capable to weld pipes d 160mm up to PN10. The wooden box is usable as working bench as well as for transportation.
- Pressure adjustment via direct load transfer (max. force 100kp)
- Planer and heating element could be swivelled in and out
- High performance heating element thermostatic controlled (PTFE coated)
- The heating element can be used as manual fusion tool
- V-shaped pipe support d 40 - 140 mm
- Reduction clamping inserts d 40 - 140 mm
- Base clamping plates right and left, d 160 mm
- Machine specific tool set

d-d [mm]	Performance	Code	kg	
40 - 160	230 V/800 W	790 301 000	90.000	

PF 3 10 585



Reduction clamping inserts

- 1 Code Nr. includes 4 half-shells

PF 3 25 117



Inserts for pipe support

- 1 Code Nr. Includes 2 supports

PF 3 25 117

d [mm]	Code	kg	



1 Set planer blades

- (1 set = 2 blades)

Code	kg	
790 113 056	0.080	

SG 160 Combined butt and socket fusion machine

for fusion jointing PP, PE and PVDF pipes and fittings size range for butt fusion d 32 - 160

Mobile, very compact and universal plastic fusion machine for use in the workshop and on job sites

Butt fusion d 32 - 160 mm, all pressure ratings up to PN 16.

Socket fusion d 16 - 110 mm



Basic machine

- high precision, distortion-free and robust machine base
- handwheel for easy moving of machine carriage
- exact pressure adjustment via direct load transfer
- hardened, hard-chrome plated guide shafts for extreme loads
- handle for safe transport of machine
- All clamping possibilities for base clamping plates, pipe supports, back stop and prismatic clamping devices.

Planer

- planing device made of light cast aluminium
- optimised cutting geometry for even and chatter-free planing
- powerful parallel planer, swivels in and out for single or double-sided facing of pipe ends 620 W
- integrated pick up for easy mounting of calibration tools for machining of pipe ends in socket fusion

Heater

- high-performance and precision heater with electronic temperature control 1500 W
- high accuracy of +/- 4°C over the entire heating surface
- heater temperature can be set exactly with digital LCD
- high quality, non-stick, easy to change PTFE fabric (Teflon)

Additional standard equipment on the basic model

- V-shaped pipe supports d 16 - 160 mm for fittings
- timer to clock fusion times
- tool set specified to machine

d-d [mm]	Performance	Code	kg	
16 - 160	230 V	790 103 031	45.000	
16 - 160	115 V	790 103 033	45.000	

PF 3 25 123



PF 3 25 117

Special transport crate

- Compact and sturdy for proper transportation and safe storage
- Multifunctional, can be used as a workbench for ergonomic working position
- Two integrated drawers to store all accessories
- Dimensions 1 m height x 1,2 m length x 0.8 m width

Code	kg
790 103 099	108.000



PF 3 25 117

Base clamping plates

- In order to improve the quality of the fusion joint, and for reliable clamping of long pipes, we recommend using the maximum number of clamping devices.
- For welding of long pipes we recommend to use the outer left and outer right base clamping plates as well.
- L = left
- R = right

d [mm]	Type	Code	kg
160	L	790 103 010	2.415
160	R	790 103 011	2.415



PF 3 25 117

Inserts, left/right

- For base clamping plate
- Left or right

d [mm]	Code	kg
32	790 103 019	0.315
40	790 103 020	0.310
50	790 103 021	0.295
63	790 103 022	0.280
75	790 103 023	0.255
90	790 103 024	0.225
110	790 103 025	0.175
125	790 103 026	0.130
140	790 103 027	0.080



Clamping bracket, left/right

- For base clamping plate
- L = left
- R = right

* Threaded clamping bracket, for mounting inserts d 32 - 140 mm. An additional insert must be used instead of clamping brackets d 32 - 140 mm, i.e. twice the number of inserts listed must be ordered.

d [mm]	Type	Code	kg
32	L	790 103 039	0.540
40	L	790 103 040	0.525
50	L	790 103 041	0.515
63	L	790 103 042	0.490
75	L	790 103 043	0.500
90	L	790 103 044	0.565
110	L	790 103 045	0.570
125	L	790 103 046	0.575
140	L	790 103 047	0.565
*160	L	790 103 048	0.655
32	R	790 103 059	0.540
40	R	790 103 060	0.525
50	R	790 103 061	0.515
63	R	790 103 062	0.490
75	R	790 103 063	0.500
90	R	790 103 064	0.565
110	R	790 103 065	0.570
125	R	790 103 066	0.575
140	R	790 103 067	0.565
*160	R	790 103 068	0.655

PF 3 25 117



Prismatic clamping device

- Prismatic clamping device for pick up of clamping jaws for exact alignment of fusion components
- L = left
- R = right

*Horizontal adjustable

Type	Code	kg
L	790 103 080	5.680
*R	790 103 081	5.680

PF 3 25 117



Clamping jaws

- For prismatic base units, left/right
- Each code number defines 1 piece prismatic clamping device. For socket fusion 4 pieces are needed.

Version	Code	kg
16-32 / 90-110	790 103 085	0.330
30-50 / 50-90	790 103 086	0.315

PF 3 25 117



Depth stop, complete

- Warrants the correct insertion depth of the pipe in the fittings socket
- Built-in spring for easier removal of fusion components from the heater. Damage to the plastified fusion surfaces is prevented.

Code	kg
790 103 090	0.610

PF 3 25 117



Heating spigots and bushes

- Aluminium, PTFE coated
- 1 pair is always delivered

d [mm]	Code	kg
16	790 101 086	0.360
20	790 101 087	0.360
25	790 101 088	0.365
32	790 101 089	0.370
40	790 101 090	0.330
50	790 101 091	0.485
63	790 101 092	0.920
75	790 101 093	1.200
90	790 101 094	1.630
110	790 101 095	2.250

PF 3 25 117



Stiffener plate

- For heating bush d 110 mm
- Warrants consistent heat transfer from heater plate to heating bush 110 mm
- Is recommended for socket fusion in the dimension 110 mm

d [mm]	Code	kg
110	790 101 098	0.265

PF 3 25 117



Calibration tool

- For mechanical, standardised calibration of pipe ends in PE, PP and PVDF (to be used with planer)
- easy and time-saving removal of oxide film
- Consistent peeling quality over the entire pipe circumference

d [mm]	Code	kg
20	790 103 160	0.940
25	790 103 161	0.925
32	790 103 162	0.930
40	790 103 163	0.900
50	790 103 164	0.950
63	790 103 165	1.010
75	790 103 166	1.145
90	790 103 167	1.215
110	790 103 168	1.325

PF 3 25 117



Back stop

- Prevents the components from slipping out of the clamping device during fusion.

d-d [mm]	Code	kg
20 - 250	790 101 045	1.400

PF 3 25 117

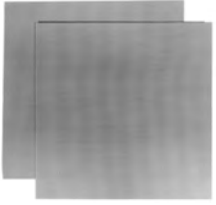

SG 160 1 Set PTFE fabric sheets

- (set of 2 pieces)
- High-quality, easy to replace, non-stick PTFE fabric (Teflon) for the heater

d [mm]	Code	kg
160	790 103 306	0.045

PF 3 25 117



SG 160 1 Set planer blades

- (1 set = 2 blades)

Code	kg
790 103 548	0.025

PF 3 25 117



Timer with 1 stop time

Code	kg
790 101 235	0.040

PF 3 25 117



Timer with 2 stop times

Code	kg
790 114 028	0.100

PF 3 25 117

SG 315 Butt fusion machine

for butt fusion jointing of PP, PE and PVDF pipes and fittings



The industrial butt fusion machine for pressure piping systems. Extremely sturdy design use in the workshop and on job sites.

Sizes d 90-315 mm, maximum fusion force 350 daN.

Basic machine

- high precision, distortion-free and robust machine base
- handwheel for easy moving of machine carriage
- fusion pressure is maintained with a user friendly torque limiter
- exact pressure adjustment via direct load transfer
- hardened, hard-chrome plated guide shafts for extreme loads
- handle for safe transport of machine
- optional outer, horizontally removeable clamping devices available

Planer

- optimised cutting geometry for even and chatter-free planing
- powerful parallel planer, swivels in and out for single or double-sided facing of pipe ends, 1100 W
- for your personal safety, a safety switch has been integrated to prevent unintentional start-up in the working position

Heater

- high-performance and precision heater with electronic temperature control 1700 W
- high accuracy of +/- 4°C over the entire heating surface
- heater temperature can be set exactly with digital LCD
- high quality, non-stick, easy to change PTFE coating
- with digital temperature indicator

Additional standard equipment included in the base model

- inner left and right clamping plates, d 315 mm, for pick up of reduction clamping inserts d 90 - 280 mm
- pipe supports d 315 mm for support of fittings
- timer to clock fusion times
- tool set specified to machine

d-d [mm]	Performance	Code	kg	
90 - 315	230 V	790 130 001	128.000	
90 - 315	115 V	790 130 002	128.000	

PF 3 25 124



for butt fusion jointing of PP, PE and PVDF pipes and fittings

The industrial butt fusion machine for pressure piping systems.
 The S-version (S = segment) additionally allows prefabrication of segments.
 Sizes d 90-315 mm, maximum fusion force 350 daN.

Basic machine

- integrated swivel tables for equalization of wall offset transverse to axial direction, for segment fusion up to 30°
- optional outer, horizontally removeable clamping devices available
- high precision, distortion-free and robust machine base
- handwheel for easy moving of machine carriage
- fusion pressure is maintained with a user friendly torque limiter
- exact pressure adjustment via direct load transfer
- hardened, hard-chrome plated guide shafts for extreme loads
- handle for safe transport of machine

Planer

- optimised cutting geometry for even and chatter-free planing
- powerful parallel planer, swivels in and out for single or double-sided facing of pipe ends, 1100 W
- for your personal safety, a safety switch has been integrated to prevent unintentional start-up in the working position

Heater

- high-performance and precision heater with electronic temperature control 1700 W
- high accuracy of +/- 4°C over the entire heating surface
- heater temperature can be set exactly with digital LCD
- high quality, non-stick, easy to change PTFE coating
- with digital temperature indicator

Additional standard equipment included in the base model

- inner left and right clamping plates, d 315 mm, for pick up of reduction clamping inserts d 90 - 280 mm
- pipe supports d 315 mm for support of fittings
- timer to clock fusion times
- tool set specified to machine

d-d [mm]	Performance	Code	kg	
90 - 315	230 V	790 130 003	143.000	
90 - 315	115 V	790 130 004	143.000	

PF 3 25 124



for butt fusion jointing of PP, PE and PVDF pipes and fittings

The industrial butt fusion machine for pressure piping systems. Extremely sturdy design use in the workshop and on job sites.

Equipped with a load cell and a digital display of the fusion force.

Sizes d 90-315 mm, maximum fusion force 410 daN.

Basic machine

- high precision, distortion-free and robust machine base
- handwheel for easy moving of machine carriage
- fusion pressure is maintained with a user friendly torque limiter
- exact pressure adjustment via direct load transfer
- hardened, hard-chrome plated guide shafts for extreme loads
- handle for safe transport of machine
- digital display
- optional outer, horizontally removeable clamping devices available

Planer

- optimised cutting geometry for even and chatter-free planing
- powerful parallel planer, swivels in and out for single or double-sided facing of pipe ends, 1100 W
- for your personal safety, a safety switch has been integrated to prevent unintentional start-up in the working position

Heater

- high-performance and precision heater with electronic temperature control 1700 W
- high accuracy of +/- 4°C over the entire heating surface
- heater temperature can be set exactly with digital LCD
- high quality, non-stick, easy to change PTFE coating
- with digital temperature indicator

Additional standard equipment included in the base model

- inner left and right clamping plates, d 315 mm, for pick up of reduction clamping inserts d 90 - 280 mm
- pipe supports d 315 mm for support of fittings
- timer to clock fusion times
- tool set specified to machine

d-d [mm]	Performance	Code	kg	
90 - 315	230 V	790 130 031	128.000	
90 - 315	115 V	790 130 032	128.000	

PF 3 25 124



for butt fusion jointing of PP, PE and PVDF pipes and fittings

The industrial butt fusion machine for pressure piping systems.
The S-version (S = segment) additionally allows prefabrication of segments.
Sizes d 90-315 mm, maximum fusion force 410 daN.

Basic machine

- integrated swivel tables for equalization of wall offset transverse to axial direction, for segment fusion up to 30°
- optional outer, horizontally removeable clamping devices available
- high precision, distortion-free and robust machine base
- handwheel for easy moving of machine carriage
- fusion pressure is maintained with a user friendly torque limiter
- exact pressure adjustment via direct load transfer
- hardened, hard-chrome plated guide shafts for extreme loads
- handle for safe transport of machine
- load cell
- digital display

Planer

- optimised cutting geometry for even and chatter-free planing
- powerful parallel planer, swivels in and out for single or double-sided facing of pipe ends, 1100 W
- for your personal safety, a safety switch has been integrated to prevent unintentional start-up in the working position

Heater

- high-performance and precision heater with electronic temperature control 1700 W
- high accuracy of +/- 4°C over the entire heating surface
- heater temperature can be set exactly with digital LCD
- high quality, non-stick, easy to change PTFE coating
- with digital temperature indicator

Additional standard equipment included in the base model

- inner left and right clamping plates, d 315 mm, for pick up of reduction clamping inserts d 90 - 280 mm
- pipe supports d 315 mm for support of fittings
- timer to clock fusion times
- tool set specified to machine

d-d [mm]	Performance	Code	kg	
90 - 315	230 V	790 130 033	143.000	
90 - 315	115 V	790 130 034	145.000	

PF 3 25 124



Outer base clamping plates

- In order to improve the quality of the fusion joint, and for reliable clamping of long pipes, we recommend using the outer base clamping plates.
- L = left
- R = right

PF 3 25 117

d [mm]	Type	Code	kg
315	L	790 130 011	6.200
315	R	790 130 012	6.200



Reduction clamping inserts, narrow

- d 90 - 280 mm
- Each code number defines 1 piece of reduction clamping insert. Per machine and dimension maximum 8 narrow or wide reduction clamping inserts are needed.
- We recommend 4 wide and 4 narrow half shells.

PF 3 25 117

d [mm]	Code	kg
90	790 112 098	0.995
110	790 112 099	1.285
125	790 112 100	1.245
140	790 112 101	1.205
160	790 112 102	1.135
180	790 112 103	1.010
200	790 112 104	0.950
225	790 112 105	0.865
250	790 112 106	0.770
280	790 112 107	0.560



PF 3 25 117

Set of pipe supports

d-d [mm]	Code	kg
90 - 280	790 118 025	6.700



PF 3 25 117

Back stop

- Prevents the components from slipping out of the clamping device during fusion.

Code	kg
790 130 013	4.500



PF 3 25 117

Special transport crate

- Compact and sturdy for proper transportation and safe storage
- Multifunctional, can be used as a workbench for ergonomic working position
- Two integrated drawers to store all accessories
- Dimensions 1 m height x 1.2 m length x 0.8 m width

Code	kg
790 130 026	143.000



1set planer blades

- (1 set = 2 blades)

PF 3 25 117

Code	kg	
790 130 023	0.041	

MC 110 Butt fusion machine

Machine MC 110, complete with electric planer



- Portable butt fusion machine for use in the workshop and on job sites. For fusion jointing of PP and PE pipes and fittings as well as prefabrication of segments in the size range d 25 - 110 mm and up to PN 10.
- Machine MC 110 complete includes: machine mounting, basic machine, 2 base clamping plates (wide), base clamping plate (left narrow), planer, heater thermostatic controlled, table clamp and transport crate.
- (as described below, including transport packaging, without accessories)

d-d [mm]	Performance	Code	kg
25 - 110	230 V/ 800 W	790 109 303	31.000
25 - 110	115 V/ 800 W	790 109 321	31.000

PF 3 25 368

MC 110 complete with manual planer



- Portable butt fusion machine for use in the workshop and on job sites. For fusion jointing of PP and PE pipes and fittings as well as prefabrication of segments in the size range d 25 - 110 mm and up to PN 10.
- Machine MC 110 complete includes: machine mounting, basic machine, 2 base clamping plates (wide), base clamping plate (left narrow), planer, heater thermostatic controlled, table clamp and transport crate.
- (as described below, including transport packaging, without accessories)

d-d [mm]	Performance	Code	kg
25 - 110	230 V/800W	790 109 301	31.000
25 - 110	115 V/800W	790 109 320	31.000

PF 3 25 368

Machine mounting



- For mounting the basic machine and fastening the complete MC 110 on the workbench

Code	kg
790 109 306	0.900



Basic machine

- With spring resistance for pressure build-up and tool set

d-d [mm]	Code	kg
25 - 110	790 109 307	6.000



Base clamping plate, wide

- 110 mm for pipe/pipe joints
- For mounting the wide reduction clamping inserts
- Freely adjustable (max. 15°)
- (set of 2 pieces)

d [mm]	Code	kg
110	790 109 308	1.200

PF 3 25 117



Base clamping plate, left narrow

- 110 mm for fitting/pipe joints
- For mounting the narrow reduction clamping inserts
- Freely adjustable (max. 15°)
- (1 piece)

d [mm]	Code	kg
110	790 109 309	1.000

PF 3 25 117



Planer, electrically operated

- Centre of planing radial adjustable.

d-d [mm]	Performance	Code	kg
25 - 110	230V/560W	790 109 312	4.900
25 - 110	115V/560W	790 109 324	4.900

PF 3 25 117



Planer, manually operated

- With ratchet mechanism
- Stops on guide shaft can be locked
- Cutting blades sharpended on both sides

d-d [mm]	Code	kg
25 - 110	790 109 311	2.300

PF 3 25 117



Heater

- Thermostatic temperature control, variable setting
- With machine mounting
- Control light for mains voltage and heating intervals
- PTFE- coating

d-d [mm]	Performance	Code	kg
25 - 110	230V/800W	790 109 313	2.600
25 - 110	115V/800W	790 109 322	2.600

PF 3 25 117



Table clamp

- For correct placement of heater

Code	kg
790 109 315	0.700



Transport crate

Code	kg
790 109 317	13.000

PF 3 25 117



Reduction clamping inserts, wide

- 25 - 90 mm
- Each code number defines 1 half shell. Per wide base clamping plate 2 reduction half -shells are needed.

d [mm]	Code	kg	
25	790 109 327	0.150	
32	790 109 328	0.150	
40	790 109 329	0.145	
50	790 109 330	0.129	
56	790 109 342	0.150	
63	790 109 331	0.125	
75	790 109 332	0.113	
90	790 109 333	0.105	

PF 3 25 117



Reduction clamping inserts, narrow

- 25 - 90 mm
- Each code number defines 1 half shell. Per wide base clamping plate 2 reduction half -shells are needed.

d [mm]	Code	kg	
25	790 109 335	0.075	
32	790 109 336	0.070	
40	790 109 337	0.125	
50	790 109 338	0.124	
56	790 109 343	0.114	
63	790 109 339	0.110	
75	790 109 340	0.100	
90	790 109 341	0.100	

PF 3 25 117



Heater

- Electronic control, variable setting
- With machine mounting
- Control light for mains voltage and heating intervals
- PTFE- coating

d-d [mm]	Performance	Code	kg	
25 - 110	230 V/800 W	790 109 314	2.600	
25 - 110	115 V/800 W	790 109 323	2.600	

PF 3 25 117



Flange adapter clamping unit

- For correct clamping and fusion jointing of short end fittings

d-d [mm]	Code	kg	
25 - 110	790 109 316	1.300	

PF 3 25 117



Base clamping plate, right narrow

- 110 mm for fitting/pipe joints
- For mounting the narrow reduction clamping inserts
- Freely adjustable (max. 15°)

d [mm]	Code	kg	
110	790 109 310	1.000	

PF 3 25 117



PF 3 25 117

Replacement blades

- Sharpened on both sides (1 set = 2 pieces)



PF 3 25 117

Replacement blades

- Sharpened on both sides (1 set = 2 pieces)

Description	Code	kg	
short	790 118 043	0.045	

Weld 160 Butt fusion machine

For fusion jointing of PP and PE pipes and fittings, size range d 40 - 160mm



- Economical, lightweight plastic fusion machine for mobile use. Suitable for plumbing installations, roof drainage systems and drainage pipes.
- **Basic machine** for butt fusion from d 40 up to d 160 mm, PN 4 (PE 80). Sliding carriages, pressure device 600 N scale. Support for heating element.
- **Planer** compact unit with reversible blades.
- **Heating element** thermostatic controlled, PTFE coated, electric cable with plug. Can also be used as a manual tool.
- **Steel frame** used for operation and transportation protection.
- Reduction clamping inserts d 40 - 140 mm
- V-shaped pipe support d 40 - 140 mm
- Base clamping plates right and left, d 160 mm

d-d [mm]	Performance	Code	kg	
40 - 160	230 V/800 W	790 301 020	50.000	
40 - 160	115 V/800 W	790 301 021	50.000	

PF 3 10 584



1 Set planer blades

- (1 set = 2 blades)

Code	kg	
790 113 056	0.080	

Weld 250 Butt fusion machine

For fusion jointing of PP and PE pipes and fittings, size range d 90 - 250mm



- Economical, lightweight plastic fusion machine for mobile use. Suitable for plumbing installations, roof drainage systems and drainage pipes.
- **Basic machine** for butt fusion from d 90 up to d 250 mm, PN 4 (PE 80). Sliding carriages, pressure device 1000 N scale. Support for heating element.
- **Planer** compact unit with reversible blades.
- **Steel frame** used for operation and transportation protection.
- **Heating element** thermostatic controlled, PTFE coated, electric cable with plug. Can also be used as a manual tool.
- Complete with reduction clamping inserts d 90 - 225 mm
- Pipe support inserts d 90 - 225 mm included

d-d [mm]	Performance	Code	kg	
90 - 250	230 V/1500 W	790 311 020	90.000	
90 - 250	115 V/1500 W	790 311 021	73.000	

PF 3 10 584

Reduction clamping inserts

- 1 Code Nr. includes 4 half-shells



d [mm]	Code	kg	
90	790 311 050	3.000	
110	790 311 051	2.750	
125	790 311 052	2.350	
140	790 311 053	2.200	
160	790 311 054	2.100	
154	790 311 055	1.800	
200	790 311 056	1.500	
225	790 311 057	1.000	

PF 3 10 586

Inserts for pipe support

- 1 Code Nr. Includes 2 supports



d [mm]	Code	kg	
90	790 311 060	1.400	
110	790 311 061	1.350	
125	790 311 062	1.150	
140	790 311 063	1.100	
160	790 311 064	1.000	
154	790 311 065	0.900	
200	790 311 066	0.750	
225	790 311 067	0.500	

PF 3 10 586

1 set planer blades

- (set of 2 blades)



Code	kg	
790 115 024	0.060	

PF 3 10 586

PPC Plastic pipe cutter

PPC Plastic pipe cutter

- For cutting plastic pipes d10 - d160



PF 3 25 117

d-d [mm]	Article	Code	kg	
10 - 63	PPC 63, s max. = 7,2mm	790 109 001	0.710	
50 - 110	PPC 110, s max. = 12.7mm	790 109 002	1.400	
110 - 160	PPC 160, s max. = 19,0mm	790 109 003	1.880	

Replacement cutting wheels

- for plastic pipe cutter



PF 3 25 117

d-d [mm]	Article	Code	kg	
10 - 63	SR 63 max. s=7,2 mm	790 109 011	0.004	
50 - 110	SR 110/160 max. s=12,7 mm	790 109 012	0.015	
110 - 160	SR 160 max. s=19,0 mm	790 109 013	0.023	

KS 355



Plastic pipe cutter

- The KS 355 is the ideal tool for simple right angle precision cutting of PVC, PE and PP pipes, Size range d 160 to 355 mm with a minimum wall thickness up to 40 mm. Including transport box.
- Unique clamping mechanism, no additional tools like belts, chains or reduction inserts necessary

d-d [mm]	Code	kg	
160 - 355	790 202 001	35.000	

PF 3 25 129



Saw blade Ø 180x30

Code	kg	
790 202 011	0.485	

PF 3 25 119

KS 1600



Plastic pipe cutter

The KS 1600 is prepared to cut plastic-pipes from diameter 355 mm up to 1600 mm with a wall thickness of max. 60 mm, fast, clean and properly right-angled. For each pipe-diameter the appropriate chain length is necessary. The saw is to put on the tensioned chain as per user manual and serves as a guiding device for the saw over a full 360° turn.

The guard plate covers the saw blade also during operation and provides full protection for the user all the time.

The KS 1600 Basis-Kit consists of a hand-circular saw, 230 V / 2200 W with carriage, 2 tension chains for d 560 mm and d 630 mm as well as a chain tensioner. The whole equipment is to be placed easily into the convenient and robust transport box.

The easy handling and the optimal safety factor do make this tool indispensable on each building site.

Scope of delivery:

1 Hand-circular saw, 1 tensioning chain d 560 mm, 1 tensioning chain d 630, 1 chain tensioner, 1 hex-wrench size 5, 1 hex-wrench size 6, 1 operating instruction, transport-box

Technical data:

Dimension range:	355 –1600 mm (By usage of the respective tensioning chain)
Plug:	EU-Plug
Voltage:	230 V AC
Power:	2200 Watt
Frequency:	50-60 Hz
Circular saw blade outer-Ø:	240 mm
RPM:	4100
Sound level:	104 dB (A)
Weight saw:	15, 5 kg
Weight KS 1600 Basic-Kit:	43,5 kg
Dimensions saw (WxHxD):	790 x 330 x 335 mm
Dimensions Transport-Box:	950 x 400 x 395 mm

PF 2 51 305

d-d [mm]	Type	Code	kg
355 - 1600	KS 1600 Basic Kit	790 109 600	43.000

Saw blade

PF 3 25 119

Description	Code	kg
Saw Blade 240X3,0X30, 18 teeth punched	790 109 618	0.653

BS Belt Saws

BS 450 Belt saw size range d 90 - 450 mm



- For exact cutting of PE, PP, PVC and PVDF plastic pipes, size range d 90 - 450 mm
- Pipe cutter with sturdy tubular steel stand and integrated V-bed
- Variable clamping system for fastening the pipe in the V-bed
- Angles from 0° to 45° to one side can be freely adjusted
- Easy to disassemble into subcomponents and transport to job sites
- Spring-resilient lowering of saw bow
- Easy saw blade replacement system with centering mechanism
- Application: up to d 160 PN 10, up to d 250 PN 6, up to d 450 PN 3,2

d-d [mm]	Code	kg	
90 - 450	790 109 045	160.000	

PF 3 25 129

BS 315/BS 630 Belt saw



- Angles from 0° to 45° to one side can be freely adjusted
- For exact cutting of PE, PP, PVC and PVDF pipes, size range d 100 - 315 mm and 200 - 630 mm
- Pipe cutter with sturdy tubular steel stand
- Variable clamping system for fastening the pipe in the V-bed
- Spring-resilient lowering of saw bow
- Easy saw blade replacement system with centering mechanism

d-d [mm]	Code	kg	
100 - 315	790 109 043	240.000	
200 - 630	790 109 047	340.000	

PF 3 25 129

BS 1200 and bigger



- Angles from 0° to 67,5° to one side can be freely adjusted
- Pipe cutter with sturdy tubular steel stand

Description	Code	
on request	-	

PF 3 25 119

BS Wearing Parts

- Saw belt for

Article	Code	kg	
BS 315	790 109 044	0.300	
BS 450	790 109 046	0.400	
BS 630	790 109 048	0.500	

PF 3 25 119

On request!

Code	

Tools for pipeline construction

Manual pipe peeling and chamfering tools



PF 2 51 305

d [mm]	Code	kg
20	799 300 260	0.059
25	799 300 270	0.074
32	799 300 280	0.100
40	799 300 290	0.259
50	799 300 300	0.299
63	799 300 310	0.513
75	799 300 320	0.750
90	799 300 330	1.070
110	799 300 340	1.350

Spare blades for calibration tools Schälmesser

- 3 pieces are required per dimension

PF 2 51 305

d [mm]	Code	kg
20	799 300 266	0.005
25	799 300 276	0.005
32	799 300 286	0.006
40	799 300 296	0.018
50	799 300 306	0.018
63	799 300 316	0.020
75	799 300 326	0.028
90	799 300 336	0.035
110	799 300 346	0.038

Spare konus handle for calibration tools

PF 2 51 305

d-d [mm]	Article	Code	kg
45 - 50	M6	799 300 295	0.030
63 - 110	M8	799 300 315	0.056



PF 3 10 590

Chamfering tool

- The perfect tool for PE, PB and PVC

d-d [mm]	Code	kg
40 - 200	790 309 001	1.600
50 - 315	790 309 002	3.170

Spare blades for chamfering tool

PF 3 10 590

d-d [mm]	Code	kg
25 - 63	761 066 795	0.016
40 - 315	790 309 015	0.040

Miscellaneous accessories org

Vice for plastic pipes



PF 3 25 119

d-d [mm]	Code	kg	
20 - 250	790 052 231	5.500	

Pipe support for vice



PF 3 25 119

d-d [mm]	Code	kg	
20 - 250	790 052 228	0.650	

Pipe vice

- For pipe dimensions 20 - 300 mm.
- Drehbar."



PF 3 24 351

d-d [mm]	Code	kg	
20 - 300	790 008 008	16.400	

Timer with 1 stop time



PF 3 25 117

Code	kg	
790 101 235	0.040	

Timer with 2 stop times



PF 3 25 117

Code	kg	
790 114 028	0.100	

Protective gloves

- (1 pair) for changing heating bush and spigot sizes without damaging the coating



PF 3 25 117

Code	kg	
790 101 305	0.400	



Tempil sticks

Code	kg	
790 101 135	0.015	
790 101 137	0.015	
790 101 139	0.015	
790 101 141	0.015	
790 101 142	0.015	
790 101 144	0.015	

PF 3 25 117



Digital-temperature measuring device

- With surface sensor and case
- Measuring range - 50 °C to + 1150 °C
- LCD-Display
- Power supply: 9 V-battery
- Surface sensor NiCr-Ni
- Case with foam lining

Code	kg	
790 109 080	0.445	

PF 3 25 117

Plastic Cleaning Agents

Degreasing Tissues

- For degreasing the PE pipe surface prior to fusion.



PF 2 51 305

Type	Code	kg	Description
small	799 496 010	0.005	For pipes up to d 63mm
large	799 496 011	0.010	For pipes up to d 225mm

Tangit KS Cleaning Tissues

- Special cleaning agent for plastic fusion connections with PP, PE, PVDF and PB.
- Scope of delivery: Standard packing 8 boxes with 100 tissues each



PF 2 28 473

Code	RSK	kg
799 298 024	4051359	3.245

Cleaning tissue KO-TON-R

- This cleaning tissue is suitable for the cleaning of the welding zone of piping components, because it is lint free and clean room checked.



1) Minimum order quantity 50 pieces

Code	kg
790 122 085	0.004

KS Tangit Cleaner

F

- Special cleaning agent for plastic fusion connections with PP, PE, PVDF and PB.



PF 2 28 473

Code	kg
799 298 023	0.890

Electrofusion Units and Accessories



MSA 400 Traceability Electrofusion Unit

Professional electrofusion unit for traceability of piping system components from raw material to completed electrofusion joint (to ISO 12176). The MSA units with the unique inverter technology and the active cooling system for trouble-free operation from generator or mains supply. Suitable for jointing in series. The unit is equipped with barcode reader pen and a memory card (exchangeable data carrier). The unit is robust, light and easy to use. The menu has up to 24 different languages. Inclusive 1 transport case, 1 pair of angle adapter clips 4.0mm, operating instructions, configuration card and Software MSA WIN-WELD.

Technical Data

Ambient temperature	-10 °C - +45 °C
Mains voltage	180 V - 264 V AC
Mains frequency	45Hz - 65 Hz
Fusion voltage	8 - 42 (48) V AC
Fusion current	max. 80 A
Power	max. 3500 W
Protection	1 / IP 65
Mains cable	3 m
Fusion cable	3 m
Dimensions (WxHxD)	285 x 360 x 200 mm
Weight incl. cables	ca. 11,5 kg, light-weight aluminium housing
Display	LCD graphic, background light, contrast adjustment
Size display (WxH)	132 x 39 mm
Type size	8 mm
Languages	German, English, French, Chinese, Czech, Hungarian, Italian, Norwegian, Dutch, Polish, Rumanian, Slovakian, Portuguese, Danish, Spanish, Estonian, Finnish, Croatian, Lithuanian, Swedish, Slovenian, Turkish, Russian, Bulgarian
Warranty	24 months

Type	Code	kg	Description
MSA 400	799 350 376	16.800	Standard, with barcode reader pen+transport case
MSA 400	799 350 451	16.800	Plus, with barcode scanner+transport case
MSA 400	799 350 384	16.800	Standard CH power plug, with barcode reader pen+transport case

PF 2 51 306



MSA 350 Record Electrofusion Unit

Professional electrofusion unit for recording jointing data of electrofusion components as a basis for electronic joint recording. The MSA units with the unique inverter technology and the active cooling system for trouble-free operation from generator or mains supply. Suitable for jointing in series. The unit is equipped with barcode reader pen, optional with barcode scanner. The unit is robust, light and easy to use. The menu has up to 24 different languages. Inclusive transport box, 1 pair of angle adapter clips 4.0 mm, operating instructions, configuration card and Software MSA WIN-WELD. (for read out of fusion data are the Data transfer cable PC, Code 799 350 385 or the Memory card 256 kB, Code 799 350 395 required).

Technical Data

Ambient temperature	-10 °C - +45 °C
Mains voltage	180 V - 264 V AC
Mains frequency	45Hz - 65 Hz
Fusion voltage	8 - 42 (48) V AC
Fusion current	max. 80 A
Power	max. 3500 W
Protection	1 / IP 65
Mains cable	3 m
Fusion cable	3 m
Dimensions (WxHxD)	285 x 360 x 200 mm
Weight incl. cables	ca. 11,5 kg, light-weight aluminium housing
Display	LCD graphic, background light, contrast adjustment
Size display (WxH)	132 x 39 mm
Type size	8 mm
Languages	German, English, French, Chinese, Czech, Hungarian, Italian, Norwegian, Dutch, Polish, Rumanian, Slovakian, Portuguese, Danish, Spanish, Estonian, Finnish, Croatian, Lithuanian, Swedish, Slovenian, Turkish, Russian, Bulgarian
Warranty	24 months

Type	Code	kg	Description
MSA 350	799 350 391	11.500	Standard, with barcode reader pen+transport case
MSA 350	799 350 441	16.800	Plus, with barcode scanner+transport case
MSA 350	799 350 392	16.800	Standard CH Power plug, with barcode reader+transport case

PF 2 51 306



MSA 300 Automatic Electrofusion Unit

Automatic electrofusion unit with barcode reader pen, optional with barcode scanner. The MSA units with the unique inverter technology and the active cooling system for trouble-free operation from generator or mains supply. Suitable for jointing in series. The unit is robust, light and easy to use. The menu has up to 24 different languages. Inclusive transport box, 1 pair of angle adapter clips 4.0 mm, operating instructions and configuration card.

Technical Data

Ambient temperature	-10 °C - +45 °C
Mains voltage	180 V - 264 V AC
Mains frequency	45Hz - 65 Hz
Fusion voltage	8 - 42 (48) V AC
Fusion current	max. 80 A
Power	max. 3500 W
Protection	1 / IP 65
Mains cable	3 m
Fusion cable	3 m
Dimensions (WxHxD)	285 x 360 x 200 mm
Weight incl. cables	ca. 11,5 kg, light-weight aluminium housing
Display	LCD graphic, background light, contrast adjustment
Size display (WxH)	132 x 39 mm
Type size	8 mm
Languages	German, English, French, Chinese, Czech, Hungarian, Italian, Norwegian, Dutch, Polish, Rumanian, Slovakian, Portuguese, Danish, Spanish, Estonian, Finnish, Croatian, Lithuanian, Swedish, Slovenian, Turkish, Russian, Bulgarian
Warranty	24 months

Type	Code	kg	Description
MSA 300	799 350 375	16.800	Standard, with barcode reader pen+transport case
MSA 300	799 350 431	16.800	Plus, with barcode scanner+transport case
MSA 300	799 350 383	16.800	Standard CH Power plug, with barcode reader pen+transport case

PF 2 51 306



MSA 250 Automatic Electrofusion Unit

Automatic electrofusion unit with barcode reader pen, optional with barcode scanner. The MSA units with the unique inverter technology and the active cooling system for trouble-free operation from generator or mains supply. Suitable for jointing in series. The unit is robust, light and easy to use. Single push-button operation, display shows fusion time and energy consumed. Inclusive transport box, 1 pair of angle adapter clips 4.0 mm and operating instructions.

Technical Data

Ambient temperature	-10 °C - +45 °C
Mains voltage	180 V - 264 V AC
Mains frequency	45Hz - 65 Hz
Fusion voltage	8 - 42 (48) V AC
Fusion current	max. 80 A
Power	max. 3500 W
Protection	1 / IP 65
Mains cable	3 m
Fusion cable	3 m
Dimensions (WxHxD)	285 x 360 x 200 mm
Weight incl. cables	ca. 11,5 kg, light-weight aluminium housing
Display	LED 1 x 4 N, 7 Segments
Size display (WxH)	50 x 18 mm
Type size	14 mm
Warranty	24 months

Type	Code	kg	Description
MSA 250	799 350 407	16.800	Standard, with barcode reader pen+transport case
MSA 250	799 350 421	16.800	Plus, with barcode scanner+transport case
MSA 250	799 350 406	16.800	Standard, with CH power adapter, barcode reader pen+transport case

PF 2 51 306



Adapter

- Adapters for electrofusion units with 4 mm connectors. Compatible with electrofusion units MSA 200, MSA 250, MSA 300, MSA 350 and MSA 400.
- Scope of delivery: 1 pair (2 pieces). (As additional components. One pair of adapters are provided with all MSA 250, MSA 300, MSA 350 and MSA 400 control units).

Type	Code	kg	Description
4,0 mm	799 350 340	0.055	Angle adapter, black
4,7 mm	799 350 341	0.059	Angle adapter, grey
4,0 mm	799 350 461	0.055	Adapter, black
4,7 mm	799 350 462	0.055	Adapter, white

PF 2 51 306



Software MSA WIN WELD

- Professional software for analysis and data management of electrofusion data, traceability data and for configuration barcodes (Z functions). Compatibility with MSA 350 (fusion data) and MSA 400 (fusion and traceability data).
- The software is suitable for Windows ME/NT4/2000/XP.
- Scope of delivery: CD-ROM, installation guide (manuals and additional information on CD-ROM)

General functions

- Reading and management of fusion data
- Sort- and filter functions
- Issue single records, collected records
- Reading and formatting of memory cards
- Reading and management of traceability data, according ISO 12176-4
- Export functions for conversion to conventional data base files, Excel or Acces
- Installed languages: German, English, French, Italian, Dutch, Croatian
- Creating individual barcodes
- Individual configuration of fusion devices

Code	kg	Description	
799 350 365	0.180	Software for MSA 350 and MSA 400	

PF 2 51 306



Software PIPE WIN WELD / SUVI WIN WELD

- Professional software for analysis and documentation of installed piping systems or of a defined part of it: Pipe book. With PIPE WIN WELD it is possible to create a complete electronic documentation of the installed pipes and pipe connection elements. The software works with the data bases of MSA WIN WELD and SUVI WIN WELD. The software makes it possible to work with data from other manufacturers (CSV module for data transfer).
- The software is suitable for Windows ME/NT4/2000/XP.
- Delivery: CD-ROM, USB hardlock (PIPE WIN-WELD, PIPE WIN-WELD CSV), installation guide (manuals and additional information on CD-ROM)

Type	Code	kg	Description
PIPE CSV	790 119 301	0.180	Complete package incl. CSV module for data transfer, USB hardlock
PIPE	790 119 302	0.180	Complete package, USB hardlock
SUVI	790 119 303	0.180	Complete package

PF 3 25 117



Cables and Data Carriers

- PC data transmission cable: to transfer fusion data directly to a PC.
- Printer transmission cable: serial/parallel interface adapter cable to provide data print-outs directly from a printer.
- Supplementary memory card: to be used as an exchangeable data carrier. A memory card is supplied with MSA 400 control units.

Type	Code	kg	Description
MSA 350/MSA 400	799 350 385	0.095	
	799 350 387	0.042	
MSA 350/MSA 400	799 350 395	0.020	

Type	Description
MSA 350/MSA 400	Data transmission cable (PC connection)
MSA 350/MSA 400	Serial-/parallel interface adapter cable, serial RJ 45/Centronics 36 (printer connection)
MSA 350/MSA 400	Memory card (record card 256 kB capacity for 400 Fusions protocols)

PF 2 51 306



Serial /Parallel Interface Adaptor Cable

Type	Code	kg	Description
MSA 350/MSA 400	799 350 387	0.042	Serial-/parallel interface adapter cable, serial RJ 45/Centronics 36 (printer connection)

PF 2 51 306



Memory Cards

Type	Code	kg	Description
MSA 350/MSA 400	799 350 395	0.020	Memory card (record card 256 kB capacity for 400 Fusions protocols)

PF 2 51 306

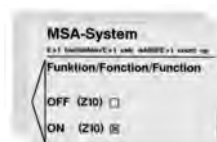

Z Function Cards for MSA 2000/3000

Type	Code	kg	Pieces	Description
MSA 2000/3000	173 281 189	0.494	100	Master card (Z3) coded
MSA 2000/3000	173 281 190	0.460	100	Order card (Z4) uncoded
MSA 2000/3000	173 281 191	0.005	100	Service card (Z6) uncoded
MSA 2000/3000	173 281 192	0.005	100	Memory card (Z8) uncoded
MSA 3000	799 350 344	0.500	100	Operator card settings (Z22) uncoded
MSA 2000/3000	173 281 247	0.238	1	Identification card set

PF 2 51 306



PF 2 51 306

Barcode Reader Pen

- Compatible with MSA 250, MSA 300, MSA 350 and MSA 400 electrofusion control units. (As additional component. A bar code reader pen or scanner is provided with all MSA 250, MSA 300, MSA 350 and MSA 400 units.)

Code	kg	Description
799 350 335	0.190	Barcode reader pen SUV1®400
799 350 337	0.046	Pouch for reader pen 799 350 335



PF 2 51 306

Barcode Readers and Adapters Barcode Scanner MSA Plus

- Robust, handy barcode scanner with a high reading performance made for the construction site. Quick, safe and professional! Compatible with MSA 250, MSA 300, MSA 350 and MSA 400 electrofusion control units.
- Scope of delivery: Barcode scanner, pouch, instructions. (As additional component. A bar code reader pen or scanner is provided with all MSA 250, MSA 300, MSA 350 and MSA 400 units).

Code	kg	Description
799 350 419	0.350	Barcode scanner

Tools for preparing pipe surfaces



Rotary Peeler RS

This innovative Rotary Peeler RS is designed to use for universal peeling at the pipe end for electrofusion couplings, tees and elbows and as well as for electrofusion saddles. Suitable for peeling of pipes made out of PE80, PE100, PEX, PP.

Feature and your advantage:

Spring loaded peeling blade: Independent peeling quality of pipe ovality or tolerances

Pivoted mounted peeling blade: To compensate the shape of coiled pipe

Optimized cutting geometry: Defined chip thickness with cutting width overlap

One tool per dimension: Minimized swivel radius for peeling in narrow locations

Divisible tool: Peeling for saddles with the same tool

Peeling length: No limitation of peeling length

Guidance rolls: 3 point support for dimensional optimized cutting feed, time saving

Guidance rolls with smooth surface: No damage of pipe surface, no dirty guidance rolls

Time saving: Tool is always ready to use, it can be used for the next peeling without setting the peeling blade back in its origin position

Your advantage: Time saving and highest repeatable peeling quality at smallest rotation radius. No operator errors possible for change of dimension.

Included: 1 x Rotary Peeler RS, Transport case, Operating manual, Spare parts list

Article	d [mm]	Code	kg
RS 40	40	790 136 001	1.250
RS 50	50	790 136 002	1.250
RS 63	63	790 136 003	1.250
RS 75	75	790 136 004	1.450
RS 90	90	790 136 005	1.450
RS 110	110	790 136 006	1.450
RS 125	125	790 136 007	1.650
RS 140	140	790 136 008	1.650
RS 160	160	790 136 009	1.650
RS 180	180	790 136 010	1.850
RS 200	200	790 136 011	1.850
RS 225	225	790 136 012	1.850
RS 250	250	790 136 013	2.150
RS 280	280	790 136 014	2.150
RS 315	315	790 136 015	2.150

PF 3 25 879

Replacement blade to Rotary Peeler RS

d-d [mm]	Code	kg
40 - 315	790 136 112	0.013

PF 3 25 118



Transport cases for Rotary Peeler RS



- Included in the scope of delivery of the Rotary Peeler RS

Article	Description	Dimension	Code	kg
RSTC 40-110	Transport case for RS 40-RS 110	326x222x116 mm	790 136 211	0.715
RSTC 125-160	Transport case for RS 125-RS 160	437x395x116 mm	790 136 212	1.212
RSTC 180-225	Transport case for RS 180-RS 225	450x360x132 mm	790 136 213	1.925
RSTC 250-315	Transport case for RS 250-RS 315	566x435x156 mm	790 136 214	2.910

PF 3 25 879

9 300 725

Peeling Tool PT 1 E



- The rotating Peeling Tool PT 1 E is suitable for preparing pipe ends with diameters d 20 - 90 mm (when installing electrofusion couplers and fittings). The tool ensures a constant peeling quality on the complete peeling surface and is suitable for PE80, P
- Scope of delivery: 1 basic tool in a plastic carrying case, without pipe inserts. The case has sufficient space for approximately 6 pipe inserts.

d-d [mm]	Code	kg	Description
20 - 90	799 150 382	3.400	Basic Tool PT 1 E

PF 2 51 305

9 300 725

Pipe Inserts for Peeling Tool PT 1 E



d [mm]	Inch	Code	kg	Description
20	2	799 300 739	0.220	Pipe Insert SDR 11
20	3	799 300 741	0.220	Pipe Insert SDR 7
25	2	799 300 740	0.230	Pipe Insert SDR 11
25	3	799 300 742	0.230	Pipe Insert SDR 9
32	3	799 300 743	0.230	Pipe Insert SDR 11
40	4	799 300 744	0.230	Pipe Insert SDR 11
50	5	799 300 745	0.350	Pipe Insert SDR 11
63	4	799 300 725	0.475	Pipe Insert SDR 17
63	6	799 300 746	0.475	Pipe Insert SDR 11
75	5	799 300 727	0.601	Pipe Insert SDR 17
75	7	799 300 747	0.601	Pipe Insert SDR 11
90	5	799 300 748	0.834	Pipe Insert SDR 17
90	8	799 300 749	0.220	Pipe Insert SDR 11

PF 2 51 305

Accessories for Peeling Tool PT 1 E

- Replacement blade.



PT 1 E

PF 2 51 305

d-d [mm]	Piece	Code	kg	Description
20 - 90	1	799 150 383	0.150	Replacement blade, 1 piece

9 300 750

Peeling Tool PT 2



- The rotating Peeling Tools PT 2 are suitable for preparing pipe ends (when installing electrofusion couplers and fittings). The tool ensures a constant peeling quality on the complete peeling surface and is suitable for PE80, PE100 and PEX pipes.
- Scope of delivery: 1 tool (size 1, 2 or 3) in a case (size 1 in aluminium, size 2 and 3 in plastic).

d-d [mm]	Code	kg	Description
90 - 250	799 300 753	5.100	Size 1, peeling length 140 mm
110 - 400	799 300 755	7.320	Size 2, peeling length 150 mm
110 - 500	799 300 756	11.000	Size 3, peeling length 175 mm

PF 2 51 305

9 300 750

Accessories for Peeling Tool PT 2

- Replacement blade.



PT 2

d-d [mm]	Code	kg	
90 - 500	799 150 355	0.008	

9 300 700

Peeling Tool PT 4

- The easy-to-use peeling tools PT 4 are suitable for preparing pipe ends (when installing electrofusion couplers and fittings). The tools ensure a constant peeling quality on the whole peeled area and are suitable for PE80 and PE100 pipes. There is no tool service arrangement for the PT 4.
- Scope of delivery: 1 tool with exchangeable blade (4 cutting surfaces).



d [mm]	e [mm]	Code	kg	Description
20	1.9	799 300 704	0.271	Pipe Insert SDR 11
20	3.0	799 300 705	0.255	Pipe Insert SDR 7
25	2.3	799 300 706	0.308	Pipe Insert SDR 11
25	3.0	799 300 707	0.290	Pipe Insert SDR 9
32	3.0	799 300 708	0.340	Pipe Insert SDR 11
40	3.7	799 300 709	0.380	Pipe Insert SDR 11
50	4.6	799 300 710	0.436	Pipe Insert SDR 11
63	5.8	799 300 711	0.540	Pipe Insert SDR 11

PF 2 51 305

9 300 700

Accessories for Peeling Tool PT 4

- Replacement blade.



PT 4

PF 2 51 305

d-d [mm]	Piece	Code	kg	Description
20 - 63	1	799 150 275	0.006	Replacement blade with 4 cutting surfaces



Peeling Tool RTC-710



The peeling tool RTC-710 is suitable to prepare pipe ends in big dimensions (d 355-710 mm). The tool ensures a constant peeling quality on the complete peeling surface of max. 530 mm length and is suitable for PE 80 and PE 100 pipes.

Scope of delivery: 1 Scraper arm, 1 Self-centering chuck base, 2 Aluminium transport cases, 1 screwdriver, 1 spare blade, 1 span cleaning knife, 1 accessories bag.

d-d [mm]	Code	kg	Description
355 - 710	799 300 757	16.000	max. working-range 530 mm

PF 2 51 305

9 198 033

Hand Scraper

- The Hand Scraper can be used to prepare the fusion zone on PE80 pipes.



PF 2 51 305

Code	kg	Description	
799 198 094	0.100	with long handle	
799 198 033	0.100		

Clamps and installation aids

Multiple use Assembly Tool Branch fitting d140mm



PF 2 51 336

- Only to be used with Branch Fitting d140mm
- Delivered as complete Kit including screws and belt

d [mm]	Code	kg	
140	193 281 027	0.740	

9 350 358

Swivel Clamp

- The Swivel Clamp centralises pipes with dimensions from d 63 - 180 mm automatically. Suitable for coupler connections as well as reductions and bends. The 15° adjustment makes an exact positioning from 15° to 90° possible.



PF 2 51 305

d-d [mm]	Code	kg	
63 - 180	799 350 358	18.000	

9 301 475

Double Clamp

- The user-friendly Double Clamps are suitable for coupler connections. They are quickly and easily put into position and prevent pullout and pipe movements during the fusion time and cooling time.
- Scope of delivery: 1 tool consisting of 1 beam (compact), 2 vee-clamps complete with ratchet and belt.



PF 2 51 305

d-d [mm]	Code	kg
63 - 125	799 301 484	2.795
110 - 225	799 301 486	10.000
225 - 500	799 301 488	15.000

9 301 450

Quadruple Clamp

- The professional Quadruple Clamps are suitable for coupler connections. They are quickly and easily put into position and ensure a stress-free fusion. They prevent pullout and pipe movements during the fusion and cooling times.
- Recommended for difficult site conditions with large installation-induced stresses.
- Scope of delivery: 1 tool consisting of 1 beam (long), 4 vee-clamps complete with ratchet and belt.



PF 2 51 305

d-d [mm]	Code	kg
63 - 125	799 301 459	6.900
110 - 225	799 301 461	19.000
225 - 500	799 301 463	28.500

9 301 525

Twin Clamp

- The easy-to-use Twin Clamp is suitable for coupler connections on straight or coiled pipe. The clamps prevent pullout and pipe movements during the fusion and cooling time.
- Scope of delivery: 1 complete tool.



PF 2 51 305

d [mm]	Code	kg
20	799 301 536	0.498
25	799 301 537	0.471
32	799 301 538	0.756
40	799 301 539	0.876
50	799 301 540	1.167
63	799 301 541	1.438

9 301 575



PF 2 51 305

Multi Clamp

- This tool is quick and easy to use and is suitable for straight forward connections to straight lengths of pipe or saddle branch outlets with electrofusion couplers.
- Scope of delivery: 1 tool without accessories.

d-d [mm]	Code	kg	
20 - 63	799 301 575	1.409	

9 301 575



PF 2 51 305

Inserts for Multi Clamp

- The inserts are easily and quickly exchanged. A set consists of 4 inserts, each insert with 2 different dimensions.

d-d [mm]	Code	kg	Description
25 - 20	799 150 385	0.806	Inserts, Sets
32 - 20	799 150 386	0.520	Inserts, Sets
32 - 25	799 150 387	0.520	Inserts, Sets
40 - 32	799 150 388	0.520	Inserts, Sets
50 - 40	799 150 389	0.520	Inserts, Sets
63 - 32	799 150 390	0.520	Inserts, Sets
63 - 40	799 150 391	0.520	Inserts, Sets
63 - 50	799 150 392	0.520	Inserts, Sets

9 370 000



PF 2 51 305

Clamp for coiled pipe

- These clamps are easily mounted on coiled pipes. They hold the pipes in position during the fusion time and cooling phase.
- Scope of delivery: 1 tool with clamp and belt.

d-d [mm]	Code	kg	
25 - 63	799 370 007	4.000	
63 - 125	799 370 011	10.000	



PF 2 51 305

Clamping device Topload 315



- This clamp and mounting tool is used to "top-load" ELGEF® Plus Saddles onto pipes of dimensions d 280 - 315 mm.
- Scope of delivery: 1 basis mounting clamp, 1 bracket, 2 clamping screws, 2 ratchet scraps, 1 transport-box

d-d [mm]	Code	kg	
280 - 315	799 350 475	15.000	

9 150 090



PF 2 51 305

Spring Clamp for ELGEF® 24 V Reinforcing Saddles

- The Spring Clamp is used to install ELGEF® 24 V reinforcing saddles d 40 - 225 mm. The tool ensures a constant jointing pressure during the entire fusion cycle.

d-d [mm]	Code	kg	
40 - 225	799 150 090	1.289	

Tapping Tools



Assembly and Tapping Key for ELGEF® Plus Saddles

- Combination tool for tapping and tightening of fixation screws.

PF 2 51 305

Type	Code	kg	Description
8/10/17	799 198 047	0.803	For all saddles



Tapping Key for ELGEF® Plus Saddles

- With adjustable tapping depth.

PF 2 51 305

Type	Code	kg	Description
10	799 198 080	0.120	for Monobloc d 40 mm and d 50 mm
17	799 198 079	0.555	for Monobloc d 63 mm and all Duobloc saddles
12.7	799 198 091	0.600	for socket with cutter



Hexagon Key for ELGEF® Plus Saddles and Branch Fittings

- For tightening fixation screws.

PF 2 51 305

Type	Code	kg	Description
SW8	799 150 378	0.152	For all saddles and branch fittings



Tapping Adapter for ELGEF® Plus Saddles

- The Adapter is used for gas-free tapping under pressure. Type S 54 for tapping saddles with rotatable outlet d 20 - 40 mm (Tapping Tee d 32 mm). Type S 67 for tapping saddles with rotatable outlet d 50 - 63 mm (Tapping Tee d 63 mm).

PF 2 51 305

Type	Code	kg	Description
S 54	799 100 061	0.813	for Tapping Tee d 32 mm
S 67	799 100 062	1.011	for Tapping Tee d 63 mm



Pressure Test Cap for ELGEF® Plus Tapping Saddles

The cap has a Rp 3/8 connection thread and is made from galvanised steel.

Overview of Tapping adapter types and Pressure Test Cap

Type	Description
M	For Monoblock d 40 mm and 50 mm (outlets d 20 - 32 mm)
S 54	For Monoblock d 63 mm (outlets d 20 - 32 mm) and all Saddles with rotatable outlet (outlets d 20 - 40 mm) i.e Tapping-Tee d 32 mm
S 67	For all Saddles with rotatable outlet (outlets d 50 - 63 mm) i.e Tapping-Tee d 63 mm

PF 2 51 305

Type	Code	kg	Description
M	799 199 282	0.119	for Monoblock d 40 mm and d 50 mm
S 54	799 199 283	0.283	for Monoblock d 63 mm and Tapping Tee d 32 mm
S 67	799 199 286	0.461	for Tapping Tee d 63 mm



PF 2 51 305

Basic Tool Box

- The Basic Tool Box contains equipment which can be used with PE and PVC saddles. The tapping tool has an automatic feed. It is held in place on the saddle or pipe by means of a securing strap.
- Scope of delivery: tapping tool, securing belt, pipe adapter, adapter disc for PVC branch saddles, guide disc, ratchet and transport case.

Code	kg	Description
799 150 351	8.078	Basic Tool Box



PF 2 51 305

Components of Basic Tool Box Basic Tapping Tool

- Tapping Tool with automatic feed.
- Scope of delivery: 1 tapping tool and securing belt.

Code	kg	Description
799 150 015	2.261	component Basic Tool Box



PF 2 51 305

Pipe Adapter

Code	kg	Description
799 150 352	1.050	component Basic Tool Box



PF 2 51 305

Adapter Disc for PVC Tapping Saddles

Code	kg	Description
799 150 354	0.200	component Basic Tool Box



PF 2 51 305

Guiding Disc

Code	kg	Description
799 150 353	0.083	component Basic Tool Box



PF 2 51 305

Ratchet

Code	kg	Description
799 150 032	0.448	component Basic Tool Box



PF 2 51 305

Accessories for Tapping Tool PE Adapter

- The Adapter is used to locate the tapping tool on ELGEF® Plus Stop-off Saddles 53 149 200.

Code	kg	Description
799 150 359	0.742	accessories Basic Tool Box



Cutter for PE Pipes

- This cutter is suitable for PE pipes and can be used on pipes of up to d 225 mm with a wall thickness of up to 21 mm.

d [mm]	Code	kg	Description
30	799 198 013	0.131	accessories Basic Tool Box
39	799 198 012	0.215	accessories Basic Tool Box
50	799 198 057	0.278	accessories Basic Tool Box

PF 2 51 305



Cutter for PVC Pipes

- This cutter is suitable for PVC pipes and can be used on pipes with a diameter of up to 225 mm and a wall thickness of up to 12 mm.

d [mm]	Code	kg	Description
21	799 199 049	0.095	accessories Basic Tool Box
30	799 199 050	0.159	accessories Basic Tool Box
39	799 199 051	0.295	accessories Basic Tool Box

PF 2 51 305



PE Repair Plug

- PE Repair Plugs are suitable for use with ELGEF® 24 V PE Reinforcement Saddles 53 127 000.

d [mm]	Code	kg
30	799 199 088	0.012
39	799 199 089	0.019

PF 2 51 305



Hexagon Key for PVC Saddles

- The Hexagon Key is suitable for tapping water and gas mains under pressure.
- Scope of delivery: 1 hexagon key, protective cover, without rotating pin.

d-d [mm]	Code	kg	s [mm]	G [inch]
16 - 25	799 150 007	0.345	19	30
32 - 40	799 150 008	0.496	27	38
50 - 63	799 150 009	0.690	27	47

PF 2 51 305

Rotating pin for Hexagon Key

Description	Code	kg
10x350 mm	799 150 011	0.220

PF 2 51 305



Transport Box

Description	Code	kg
Replacement Transport Box to Basic Tool Box	799 150 033	4.000

PF 2 51 305

Squeeze-off and Rerounding tools

9 350 107



PF 2 51 305

Squeeze-off Tool, Type S1

- This mechanical device is used to squeeze-off PE pipes during repair and extension work. In order not to over-stress the pipe, the tool is equipped with adjustable end stops for SDR 11 (ISO S5) pipes. Due to different wall thickness` of the pipes, the squeezing degree may differ up to 0,8.

d-d [mm]	Code	kg	Description
20 - 63	799 350 107	4.449	S1 for PE pipes SDR 11

9 350 108



PF 2 51 305

Squeeze-off Tool, Type S2

- This mechanical device is used to squeeze off PE pipes during repair and extension work. In order not to over-stress the pipe, the tool is equipped with adjustable end stops for SDR 11 (ISO S5) and SDR 17 (ISO S8) pipes.

d-d [mm]	Code	kg	Description
63 - 180	799 350 108	35.800	S2 for PE pipes SDR 11 and SDR 17

9 350 270



PF 2 51 305

Squeeze-off Tool, A25

- This mechanical device is used to squeeze off PE pipes during repair and extension work. In order not to over-stress the pipe, the tool is equipped with adjustable end stops for SDR 11 (ISO S5) and SDR 17 (ISO S8) pipes.

d-d [mm]	Code	kg	Description
160 - 250	799 350 270	60.000	A25 for PE pipes SDR 11 and SDR 17

9 350 110



PF 2 51 305

Re-rounding Clamp

- Re-rounding Clamps are used to re-round squeezed-off pipes. They can be left on the squeezed-off part of the pipe as a support if so desired.

d [mm]	Code	kg
63	799 350 113	3.000
75	799 350 114	3.600
90	799 350 115	3.500
110	799 350 116	5.750
125	799 350 117	5.690
160	799 350 118	7.500
180	799 350 119	27.000
200	799 350 120	27.500
225	799 350 121	11.595
250	799 350 172	34.000



Re-rounding Tool

- Re-rounding tools are used to re-round oval pipes during fusion as well as during the cooling time.

d [mm]	Code	kg	
25	799 199 127	0.750	
32	799 199 128	0.500	
40	799 199 129	1.500	
50	799 199 130	1.250	
63	799 199 131	1.250	
75	799 199 132	1.500	
90	799 199 133	1.500	
110	799 199 134	2.000	
125	799 199 135	2.000	
160	799 199 137	2.250	
180	799 199 138	3.000	
200	799 199 139	2.500	
225	799 199 140	3.000	
250	799 199 141	3.630	

PF 2 51 305



Pressure Pad Kit



- Complete kit of assembly equipment
- Consists of 3 air pressure pads, control unit with manifold, pressure hoses, strap corset, detailed instruction leaflets and transport case
- For operation with pressurized air up to 10 bar according EN 292
- Tool for dual use: Pipe re-rounding and fusion pressure reinforcement

d-d [mm]	Code	kg	
560 - 630	799 301 561	47.900	

PF 2 51 305

Plastic Cleaning Agents

Degreasing Tissues

- For degreasing the PE pipe surface prior to fusion.



PF 2 51 305

Type	Code	kg	Description
small	799 496 010	0.005	For pipes up to d 63mm
large	799 496 011	0.010	For pipes up to d 225mm

Tangit KS Cleaning Tissues

- Special cleaning agent for plastic fusion connections with PP, PE, PVDF and PB.
- Scope of delivery: Standard packing 8 boxes with 100 tissues each



PF 2 28 473

Code	RSK	kg
799 298 024	4051359	3.245

KS Tangit Cleaner

F

- Special cleaning agent for plastic fusion connections with PP, PE, PVDF and PB.



PF 2 28 473

Code	kg
799 298 023	0.890

Accessories for job sites

Roller support 315



- Up to d 315 mm, with base plate, galvanised
- The piping can be pulled with little effort
- Protects pipes from damage
- Reduces resistance during fusion
- Maximum load 300 kg

PF 3 25 117

d-d [mm]	Code	kg	
20 - 315	790 109 110	4.000	

Support 750



- Up to d 750 mm, with base plate, galvanised
- **height adjustable** (60 mm)
- The piping can be pulled with little effort
- Protects pipes from damage
- Reduces resistance during fusion
- Maximum load 1000 kg

PF 3 25 117

d-d [mm]	Code	kg	
110 - 750	790 109 109	4.115	

5 seconds tent



- Protects fusion work from adverse weather conditions
- Entrance with zip
- Additional opening for pipeline
- Material: polyester with carbon frame and plastic hinge plates
- Color: top white LP with kerchief-quality M2, base yellow Bisonyl with kerchief-quality M2
- Dimensions: Typ 180: 180 cm x 180 cm x 200 cm
- Typ 210: 210 cm x 210 cm x 200 cm
- Typ 250: 250 cm x 250 cm x 200 cm

PF 3 25 117

Article	Code	kg	
Typ 180	790 109 091	17.000	
Typ 210	790 109 092	15.000	
Typ 250	790 109 093	20.000	

Alignment Tool



- To align and position pipes in the dimension range d 110 - 400 mm. The pipes are clamped in the vice, the axial movement takes place by a chain drive. The chain is totated by the ratched (square 19 mm).

PF 3 25 117

Article	Code	kg	
Alignment Tool	790 109 108	15.000	
Ratch	790 109 107	1.220	



Marker

PF 2 55 338

Type	Code	kg	
silber	799 350 364	0.012	

General Condition of Supply of Georg Fischer Piping Systems (Switzerland) Limited, Schaffhausen

1 General

- 1.1 These General Conditions shall apply to all Products supplied by Georg Fischer to the Purchaser. They shall also apply to all future business even when no express reference is made to them
- 1.2 Any deviating or supplementary conditions especially Purchaser's general conditions of purchase and verbal agreements shall only be applicable if accepted in writing by Georg Fischer.
- 1.3 The written form shall be deemed to be fulfilled by all forms of transmission, evidenced in the form of text, such as telefax, e-mail, etc.

2 Tenders

- 2.1 Tenders shall only be binding if they contain a specifically stated period for acceptance.

3 Scope of Delivery

- 3.1 Georg Fischer's product range is subject to change.
- 3.2 The confirmation of order shall govern the scope and execution of the contract.

4 Data and Documents

- 4.1 Technical documents such as drawings, descriptions, illustrations and data on dimensions, performance and weight as well as the reference to standards are for information purposes only. They are not warranted characteristics and are subject to change.
- 4.2 All technical documents shall remain the exclusive property of Georg Fischer and may only be used for the agreed purposes or as Georg Fischer may consent.

5 Confidentiality, Protection of Personal Data

- 5.1 Each party shall keep in strict confidence all commercial or technical information relating to the business of the other party, of which it has gained knowledge in the course of its dealing with the other party. Such information shall neither be disclosed to third parties nor used for other purposes than those for which the information has been supplied.
- 5.2 In the context of the contractual relation with the Purchaser personal data may be processed. The Purchaser agrees to the disclosure of said data to third parties such as foreign subcontractors and suppliers etc.

6 Local Laws and Regulations, Export Controls

- 6.1 The Purchaser shall bring to the attention of Georg Fischer all local laws and regulations at the place of destination which bear connection with the execution of the contract and the adherence to relevant safety regulations and approval procedures.
- 6.2 In case of re-exports, Purchaser shall be responsible for compliance with pertinent export control regulations.

7 Price

- 7.1 Unless agreed otherwise, the prices shall be deemed quoted net ex works (according to Incoterms of the ICC, latest version) including standard packing. All supplementary costs such as the cost of carriage, insurance, export-, transit- and importlicences etc. shall be borne by the Purchaser. The Purchaser shall also bear the costs of all taxes, fees duties etc. connected with the contract.
- 7.2 If the costs of packing, carriage, insurance, fees and other supplementary costs are included in the tender price or contract price or are referred to specifically in the tender or confirmation of order, Georg Fischer reserve the right to revise their prices accordingly should any change occur in the relevant tariffs.

8 Terms of Payment

- 8.1 The Purchaser shall make payment in the manner agreed by the parties without any deductions such as discounts, costs, taxes or dues.
- 8.2 The Purchaser may only withhold or off-set payments due against counter claims which are either expressly acknowledged by Georg Fischer or finally awarded to the Purchaser. In particular, payment shall still be made when unessential items are still out-standing provided that the Products already delivered are not rendered unusable as a result.

9 Retention of Title

- 9.1 The Products shall remain the property of Georg Fischer until the Purchaser shall have settled all claims, present and future, which Georg Fischer may have against him.
- 9.2 Should the Purchaser resell Products to which title is reserved, in the ordinary course of business, he shall hereby be deemed to have tacitly assigned to Georg Fischer the proceeds deriving from their sale together with all collateral rights, securities and reservations of title until all claims held by Georg Fischer shall have been settled. Until revoked by Georg Fischer, this assignment shall not preclude Purchaser's right to collect the assigned receivables.
- 9.3 To the extent the value of the Products to which title is reserved together with collateral securities exceeds Georg Fischer's claims against the Purchaser by more than 20%, Georg Fischer shall re-assign the above proceeds to Purchaser at his request.

10 Delivery

- 10.1 The term of delivery shall commence as soon as the contract has been entered into, all official formalities such as import and payment permits have been obtained and all essential technical issues have been settled. The term of delivery shall be deemed duly observed when, upon its expiry, the Products are ready for despatch.
- 10.2 Delivery is subject to the following conditions, i.e. the term of delivery shall be reasonably extended:
 - a) if Georg Fischer are not supplied in time with the information necessary for the execution of the contract or if subsequent changes causing delays are made by the Purchaser.
 - b) if Georg Fischer are prevented from performing the contract by force majeure. Force majeure shall equally be deemed to be any unforeseeable event beyond Georg Fischer's control which renders Georg Fischer's performance commercially unpractical or impossible, such as delayed or defective supplies from sub contractors labour disputes, governmental orders or regulations, shortages in materials or energy, serious disturbances in Georg Fischer's works, such as the total or partial destruction of plant and equipment or the breakdown of essential facilities, serious disruptions in transport facilities, e.g. impassable roads.
Should the effect of force majeure exceed a period of six months, either party may cancel the contract forthwith.
Georg Fischer shall not be liable for any damage or loss of any kind whatsoever resulting therefrom, any suspension or cancellation being without prejudice to Georg Fischer's right to recover all sums due in respect of consignments delivered and costs incurred to date.
 - c) if the Purchaser is in delay with the fulfilment of his obligations under the contract, in particular, if he does not adhere to the agreed conditions of payment or if he has failed to timely provide the agreed securities.
- 10.3 If for reasons attributable to Georg Fischer the agreed term of delivery or a reasonable extension thereof is exceeded, Georg Fischer shall not be deemed in default until the Purchaser has granted to Georg Fischer in writing a reasonable extension thereof of not less than one month which equally is not met.
The Purchaser shall then be entitled to the remedies provided at law, it being however understood that, subject to limitations of Art. 16, damage claims shall be limited to max. 10% of the price of the delayed delivery.
- 10.4 Part shipments shall be allowed and Georg Fischer shall be entitled to invoice for such partial deliveries.
- 10.5 If the Purchaser fails to take delivery within a reasonable time of Products notified as ready for despatch, Georg Fischer shall be entitled to store the Products at the Purchaser's expense and risk and to invoice them as delivered. If Purchaser fails to effect payment, Georg Fischer shall be entitled to dispose of the Products.
- 10.6 Should Purchaser cancel an order without justification and should Georg Fischer not insist on the performance of the contract, Georg Fischer shall be entitled to liquidated damages in the amount of 10% of the contract price, Georg Fischer's right to prove and claim higher damages remaining reserved. Purchaser shall be entitled to prove, that Georg Fischer has suffered no or a considerably lower damage.

11 Packing

- 11.1 If the Products are provided with additional packing over and above the standard packing, such packing shall be charged additionally.

12 Passing of Risk

- 12.1 The risk in the Products shall pass to the Purchaser as soon as they have left Georg Fischer's works (EX WORKS, Incoterms ICC, latest version), even if delivery is made carriage-paid, under similar clauses or including installation or when carriage is organized and managed by Georg Fischer.
- 12.2 If delivery is delayed for reasons beyond Georg Fischer's control, the risk shall pass to the Purchaser when he is notified that the Products are ready for despatch.

13 Carriage and Insurance

- 13.1 Unless agreed otherwise, the Purchaser shall bear the cost of carriage.
 - 13.2 The Purchaser shall be responsible for transport insurance against damage of whatever kind. Even when such insurance is arranged by Georg Fischer it shall be deemed taken out by the order of and for the account of the Purchaser and at his risk.
 - 13.3 Special requests regarding carriage and insurance shall be communicated to Georg Fischer in due time. Otherwise carriage shall be arranged by Georg Fischer at their discretion, but without responsibility, by the quickest and cheapest method possible.
In case of carriage-paid delivery transport arrangements shall be made by Georg Fischer. If the Purchaser specifies particular requirements, any extra costs involved shall be borne by him.
 - 13.4 In the event of damage or loss of the Products during carriage the Purchaser shall mark the delivery documents accordingly and immediately have the damage ascertained by the carrier. Not readily ascertainable damages sustained during carriage shall be notified to the carrier within six days after receipt of the Products.
- ## 14 Inspection, Notification of Defects and Damages
- 14.1 The Products will be subject to normal inspection by Georg Fischer during manufacture. Additional tests required by the Purchaser shall be agreed upon in writing and shall be charged to the Purchaser.
 - 14.2 It shall be a condition of Georg Fischer's obligation under the warranties stated hereinafter that Georg Fischer be notified in writing by the Purchaser of any purported defect immediately upon discovery. Notice concerning weight, numbers or apparent defects is to be given latest within 30 days from receipt of the Products, notice of other defects immediately latest within 7 working days after discovery, in any event within the agreed warranty period.
 - 14.3 Purchaser shall not dispose of allegedly defective Products until all warranty and/or damage claims are finally settled. At its request, defective Products are to be placed at Georg Fischer's disposal.
 - 14.4 At its request, Georg Fischer shall be given the opportunity to inspect the defect and/or damage, prior to commencement of remedial work, either itself or by third party experts.

15 Warranty

- 15.1 At the written request of the Purchaser, Georg Fischer undertake to repair or replace at their discretion, as quickly as possible and free of charge all Products supplied which demonstrably suffer from faulty design, materials or workman-ship or from faulty operating or installation instructions.
In order to protect employees from toxic or radioactive substances which may have been transported through defective parts returned to Georg Fischer's sales organisation, said parts must be accompanied by a Material Safety Disclosure Form. The form may be obtained from Georg Fischer's local sales company or via www.piping.georgfischer.com.
Replaced parts shall become property of Georg Fischer.
- 15.2 For Products which are manufactured to specifications, drawings or patterns supplied by the Purchaser, Georg Fischer's warranty shall be restricted to proper materials and workmanship.
- 15.3 The Purchaser shall be entitled to cancel the contract or to demand a reduction in the contract price if also a second attempt to repair or replace the Products has failed.
- 15.4 For Products or essential components manufactured by a third party and supplied by Georg Fischer under this contract, Georg Fischer's warranty is limited to the warranty provided by said third party.
- 15.5 This warranty shall not apply to damage resulting from normal wear and tear, improper storage and maintenance, failure to observe the operating instructions, overstressing or overloading, unsuitable operating media, unsuitable construction work or unsuitable building ground, improper repairs or alterations by the Purchaser or third parties, the use of other than original spare parts and other reasons beyond Georg Fischer's control.
- 15.6 No action or claim may be brought by the Purchaser on account of any alleged breach of warranty or any other obligation of Georg Fischer after the expiration of twelve (12) months from receipt of the Products by the end user or at the latest within eighteen (18) months of the Products being despatched by Georg Fischer.
- 15.7 In case of Products for use in domestic installations or in utilities
 - Georg Fischer will assume the costs of dismantling the defective Product and restoring the damaged object as well as, in case of negligence, all other direct damages caused by the defective Product (damage to property and injury to or death of persons) up to CHF 1 000 000 per occurrence.
 - the statute of limitations for warranty or damage claims - contrary to Section 15.6 - will be 5 years from the date of installation.

16 Limitation of Liability

- 16.1 All cases of breach of contract and the relevant consequences as well as all rights and claims on the part of the customer, irrespective of what ground they are based, are exhaustively covered by these general conditions of supply. In particular, any claims not expressly mentioned for damages, reduction of price, termination of or withdrawal from the contract are excluded. In no case whatsoever shall the customer be entitled to claim damages other than compensation for costs of remedying defects in the supplies. This in particular refers, but shall not be limited, to loss of production, loss of use, loss of orders, loss of profit and other direct or indirect or consequential damage. This exclusion of liability, however, does not apply to unlawful intent or gross negligence on the part of Georg Fischer and in case of strict liability under applicable product liability statutes, but does apply to unlawful intent or gross negligence of persons employed or appointed by Georg Fischer to perform any of its obligations.

17 Severability

- 17.1 Should any term or clause of these General Conditions in whole or in part be found to be unenforceable or void, all other provisions shall remain in full force and effect and the unenforceable or void provision shall be replaced by a valid provision, which comes closest to the original intention of the unenforceable or invalid provision.

18 Place of Performance and Jurisdiction

- 18.1 Place of performance for the Products shall be the Georg Fischer works from which the Products are despatched.
- 18.2 Any civil action based upon any alleged breach of this contract shall be filed and prosecuted exclusively in the courts of Schaffhausen, Switzerland.
Georg Fischer however reserves the right to file actions in any court having jurisdiction over controversies arising out of or in connection with the present contract.
- 18.3 The contract shall be governed by Swiss law without regard to conflict of law provisions that would require the application of another law.

GF Piping Systems → worldwide at home

Our sales companies and representatives ensure local customer support in over 100 countries.

www.piping.georgfischer.com



The technical data are not binding and not expressly warranted characteristics of the goods. They are subject to change. Our General Conditions of Sale apply.

Australia

George Fischer Pty Ltd
Kingsgrove NSW 2008
Phone +61(0)2/95 54 39 77
australia.ps@georgfischer.com
www.georgfischer.com.au

Austria

Georg Fischer
Rohrleitungssysteme GmbH
3130 Herzogenburg
Phone +43(0)2782/856 43-0
austria.ps@georgfischer.com
www.georgfischer.at

Belgium / Luxembourg

Georg Fischer NV/SA
1070 Bruxelles/Brüssel
Phone +32(0)2/556 40 20
be.ps@georgfischer.com
www.georgfischer.be

Brazil

George Fischer Ltda
04795-100 São Paulo
Phone +55(0)11/5687 1311
br.ps@georgfischer.com

China

Georg Fischer
Piping Systems Ltd Shanghai
Pudong, Shanghai 201319
Phone +86(0)21/58 13 33 33
china.ps@georgfischer.com
www.cn.piping.georgfischer.com

Denmark / Iceland

Georg Fischer A/S
2630 Taastrup
Phone +45 (0)70 22 19 75
info.dk.ps@georgfischer.com
www.georgfischer.dk

France

Georg Fischer S.A.S.
93208 Saint-Denis Cedex 1
Phone +33(0)1/492 21 34 1
fr.ps@georgfischer.com
www.georgfischer.fr

Germany

Georg Fischer GmbH
73095 Albershausen
Phone +49(0)7161/302-0
info.de.ps@georgfischer.com
www.vgd.georgfischer.de

Georg Fischer DEKA GmbH
35232 Dautphetal-Mornshausen
Phone +49(0)6468/915-0
deka.ps@georgfischer.com
www.dekapipe.de

India

Georg Fischer Piping Systems Ltd
400 093 Mumbai
Phone +91(0)22/2820 2362
in.ps@georgfischer.com

Italy

Georg Fischer S.p.A.
20063 Cernusco S/N (MI)
Phone +3902/921 861
it.ps@georgfischer.com
www.georgfischer.it

Japan

Georg Fischer Ltd
556-0011 Osaka,
Phone +81(0)6/6635 2691
jp.ps@georgfischer.com
www.georgfischer.jp

Malaysia

Georg Fischer (M) Sdn. Bhd.
47500 Subang Jaya
Phone +60 (0)3-8024 7879
conne.kong@georgfischer.com.my

Middle East

Georg Fischer Piping Systems
Dubai, United Arab Emirates
Phone +971 4 289 41 20
gfdubai@emirates.net.ae
www.piping.georgfischer.com

Netherlands

Georg Fischer N.V.
8161 PA Epe
Phone +31(0)578/678 222
nl.ps@georgfischer.com
www.georgfischer.nl

Norway

Georg Fischer AS
1351 Rud
Phone +47(0)67 18 29 00
no.ps@georgfischer.com
www.georgfischer.no

Poland

Georg Fischer Sp. z o.o.
02-226 Warszawa
Phone +48(0)22/313 10 50
poland.ps@georgfischer.com
www.georgfischer.pl

Romania

Georg Fischer
Rohrleitungssysteme AG
70000 Bucharest - Sector 1
Phone +40(0)1/222 91 36
ro.ps@georgfischer.com

Singapore

Georg Fischer Pte Ltd
528 872 Singapore
Phone +65(0)67 47 06 11
sgp.ps@georgfischer.com
www.georgfischer.com.sg

Spain / Portugal

Georg Fischer S.A.
28046 Madrid
Phone +34(0)91/781 98 90
es.ps@georgfischer.com
www.georgfischer.es

Sweden / Finland

Georg Fischer AB
12523 Älvsjö-Stockholm
Phone +46(0)8/506 775 00
info.se.ps@georgfischer.com
www.georgfischer.se

Switzerland

Georg Fischer
Rohrleitungssysteme [Schweiz] AG
8201 Schaffhausen
Phone +41(0)52 631 30 26
ch.ps@georgfischer.com
www.piping.georgfischer.ch

Taiwan

Georg Fischer Ltd.
2F, No. 88, Hsing Te Road
San Chung City
Taipei Hsien, Taiwan (R.O.C.)
Phone +886 2 8512 2822
Fax +886 2 8512 2823

United Kingdom / Ireland

Georg Fischer Sales Limited
Coventry, CV2 2ST
Phone +44(0)2476 535 535
uk.ps@georgfischer.com
www.georgfischer.co.uk

USA / Canada / Latin America / Caribbean

George Fischer Inc.
Tustin, CA 92780-7258
Phone +1(714) 731 88 00
Toll Free 800/854 40 90
us.ps@georgfischer.com
www.us.piping.georgfischer.com

Export

Georg Fischer
Piping Systems (Switzerland) Ltd.
8201 Schaffhausen
Phone +41(0)52 631 30 26
Fax +41(0)52 631 28 93
export.ps@georgfischer.com
www.piping.georgfischer.com

GMST 9104/4 (3.06)

Made with MediaCockpit
© Georg Fischer Piping Systems Ltd.
8201 Schaffhausen/Switzerland, 2006
Printed in Germany

+GF+

GEORG FISCHER
PIPING SYSTEMS