

**WARREN RUPP®**

Quality System  
ISO9001 Certified

Environmental  
Management System  
ISO14001 Certified

**IDEX**  
FLUID & METERING

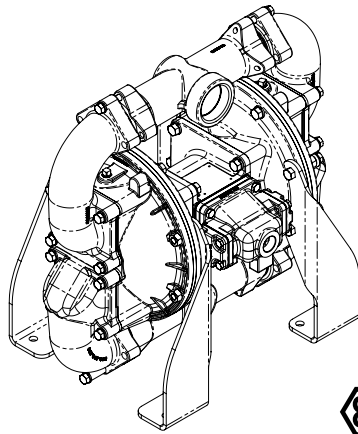

See pages 2, 5 & 6  
for ATEX ratings

**MARATHON®**  
A WARREN RUPP, INC. BRAND

**Heavy Duty Flap Valve**  
**MHDF2 Type 6**  
**Air-Operated**  
**Double Diaphragm Pump**

ENGINEERING, PERFORMANCE  
& CONSTRUCTION DATA

INTAKE/DISCHARGE PIPE SIZE 2" NPT (F)	CAPACITY 0 to 140 gallons per minute (0 to 530 liters per minute)	AIR VALVE No-lube, no-stall design	SOLIDS-HANDLING Up to 2" (50mm)	HEADS UP TO 125 psi or 289 ft. of water (8.8 Kg/cm <sup>2</sup> or 88 meters)
--	---	--	------------------------------------	---

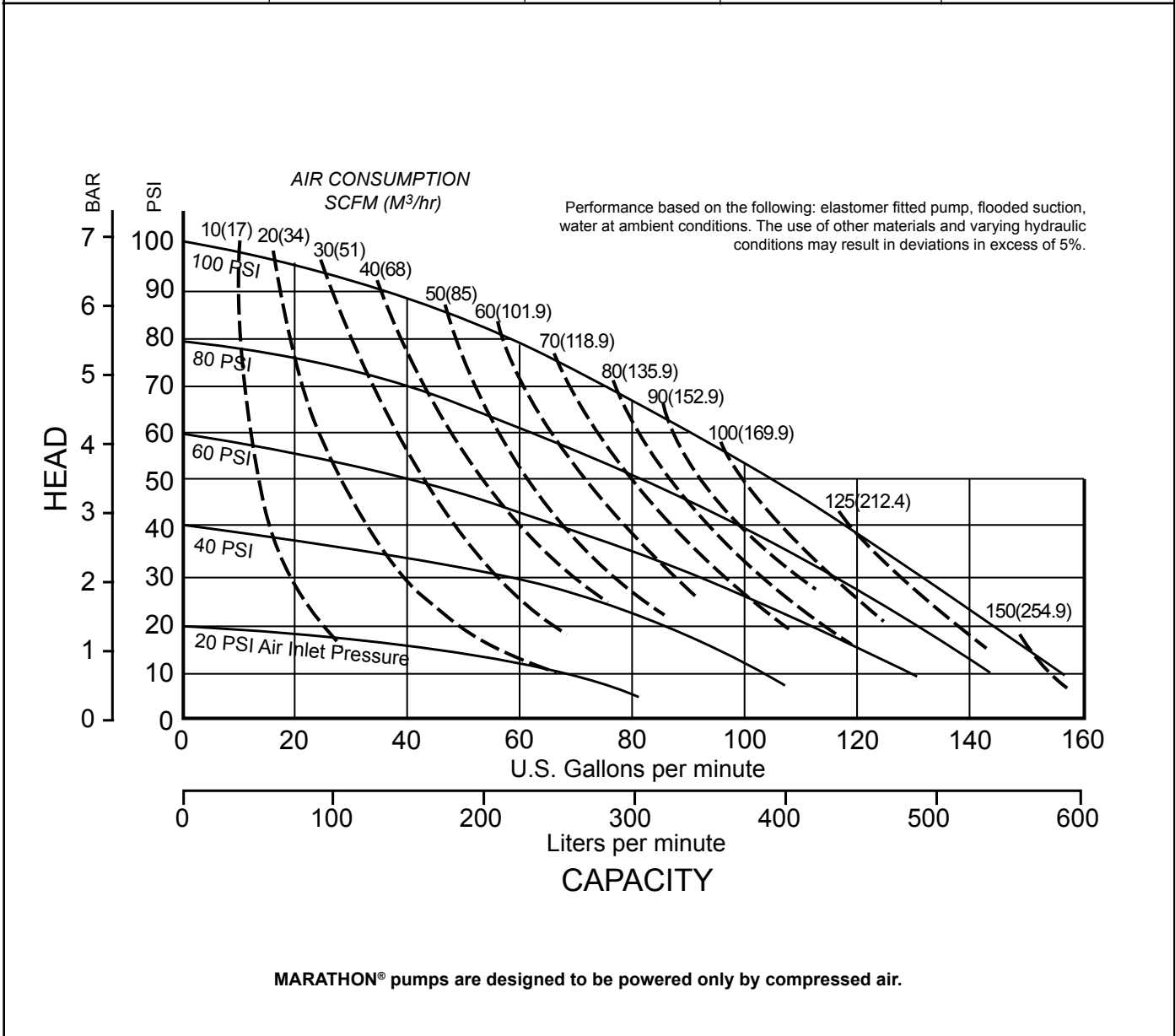

MARATHON® pumps are designed to be powered only by compressed air.

# Explanation of Pump Nomenclature, MHDF2

## MATERIALS OF CONSTRUCTION

To order a pump or replacement parts, first enter the Model Number **MHDF2**, followed by the Type Designation listed below in the far left column.

Type Designation	Manifold Elbow	Outer Chamber	Inner Chamber	Outer Diaphragm Plate	Inner Diaphragm Plate	Intermediate Housing	Diaphragm Rod	Valve Seat	Hard-ware	Diaphragm	Flap Valve Material	Sealing Rings	Shipping Wt. (lbs.)
DA6A.	AL380DC	AL380DC	AL380DC	PS	PS	356-T6AL	416SS	316SS	PS	N	U	N	86
DB6A.	AL380DC	AL380DC	AL380DC	PS	PS	356-T6AL	416SS	316SS	PS	B	B	B	86
DV6A.	AL380DC	AL380DC	AL380DC	PS	PS	356-T6AL	416SS	316SS	PS	V	V	V	86
DN6A.	AL380DC	AL380DC	AL380DC	PS	PS	356-T6AL	416SS	316SS	PS	N	N	N	86
DI6A.	AL380DC	AL380DC	AL380DC	PS	PS	356-T6AL	416SS	316SS	PS	I	I	I	86
DP6A.	AL380DC	AL380DC	AL380DC	PS	PS	356-T6AL	416SS	316SS/I	PS	S	S	I	86
DR6A.	AL380DC	AL380DC	AL380DC	PS	PS	356-T6AL	416SS	316SS	PS	H	H	N	86
DA6I.	CI	CI	AL380DC	PS	PS	356-T6AL	416SS	316SS	PS	N	U	N	133
DB6I.	CI	CI	AL380DC	PS	PS	356-T6AL	416SS	316SS	PS	B	B	B	133
DV6I.	CI	CI	AL380DC	PS	PS	356-T6AL	416SS	316SS	PS	V	V	V	133
DN6I.	CI	CI	AL380DC	PS	PS	356-T6AL	416SS	316SS	PS	N	N	N	133
DI6I.	CI	CI	AL380DC	PS	PS	356-T6AL	416SS	316SS	PS	I	I	I	133
DR6I.	CI	CI	AL380DC	PS	PS	356-T6AL	416SS	316SS	PS	H	H	N	133
DP6I.	CI	CI	AL380DC	PS	PS	356-T6AL	416SS	316SS/I	PS	S	S	I	133
DA6II.	CI	CI	CI	PS	PS	CI	416SS	316SS	PS	N	U	N	168
DB6II.	CI	CI	CI	PS	PS	CI	416SS	316SS	PS	B	B	B	168
DV6II.	CI	CI	CI	PS	PS	CI	416SS	316SS	PS	V	V	V	168
DN6II.	CI	CI	CI	PS	PS	CI	416SS	316SS	PS	N	N	N	168
DI6II.	CI	CI	CI	PS	PS	CI	416SS	316SS	PS	I	I	I	168
DP6II.	CI	CI	CI	PS	PS	CI	416SS	316SS/I	PS	S	S	I	168
DA6S.	±SS	±SS	AL380DC	±SS	PS	356-T6AL	416SS	316SS	PS	N	U	N	133
DB6S.	±SS	±SS	AL380DC	±SS	PS	356-T6AL	416SS	316SS	PS	B	B	B	133
DF6S.	±SS	±SS	AL380DC	±SS	PS	356-T6AL	416SS	316SS	PS	F	F	F	133
DV6S.	±SS	±SS	AL380DC	±SS	PS	356-T6AL	416SS	316SS	PS	V	V	V	133
DN6S.	±SS	±SS	AL380DC	±SS	PS	356-T6AL	416SS	316SS	PS	N	N	N	133
DI6S.	±SS	±SS	AL380DC	±SS	PS	356-T6AL	416SS	316SS	PS	I	I	I	133
DP6S.	±SS	±SS	AL380DC	±SS	PS	356-T6AL	416SS	316SS/I	PS	S	S	I	133
DR6S.	±SS	±SS	AL380DC	±SS	PS	356-T6AL	416SS	316SS	PS	H	H	N	133
DA6SI.	±SS	±SS	CI	±SS	PS	CI	416SS	316SS	PS	N	U	N	168
DB6SI.	±SS	±SS	CI	±SS	PS	CI	416SS	316SS	PS	B	B	B	168
DV6SI.	±SS	±SS	CI	±SS	PS	CI	416SS	316SS	PS	V	V	V	168
DN6SI.	±SS	±SS	CI	±SS	PS	CI	416SS	316SS	PS	N	N	N	168
DI6SI.	±SS	±SS	CI	±SS	PS	CI	416SS	316SS	PS	I	I	I	168
DP6SI.	±SS	±SS	CI	±SS	PS	CI	416SS	316SS/I	PS	S	S	I	168

‡ See CF-8M Materials information above.

### Meanings of Abbreviations:

A = Compressed Fibre  
AL = Aluminum  
B = Nitrile  
CI = Cast Iron

DC = Die Cast  
H = Hytrel®  
I = EPDM  
N = Neoprene

PS = Plated Steel  
S = Santoprene®  
SS = Stainless Steel  
V = FKM (Fluorocarbon)

SS/I = Stainless Steel seat with EPDM O-Ring  
T = PTFE  
U = Urethane  
F = FDA Accepted White Nitrile

Most types available in dual port design. See price book or consult factory for details.

Hytrel is a registered tradename of E.I. du Pont. Santoprene is a registered tradename of Exxon Mobil Corp.



II 1 G c T5  
II 3/1 G c T5  
II 1 D c T100°C  
I M1 c  
I M2 c

Models equipped with Cast Iron or Stainless Steel wetted parts, and Cast Iron midsection parts. See page 6 for ATEX Explanation of EC-Type Certificate.



II 2 G c T5  
II 3/2 G c T5  
II 2 D c T100°C

All models, including pumps equipped with Aluminum wetted and midsection parts.  
See page 6 for ATEX Explanation of Type Examination Certificate.

# Materials and Dimensions: MHDF2

Maximum and Minimum Temperatures are the limits for which these materials can be operated. Temperatures coupled with pressure affect the longevity of diaphragm pump components. Maximum life should not be expected at the extreme limits of the temperature ranges.

Materials	Operating Temperatures	
	Maximum	Minimum
<b>Nitrile/FDA White Nitrile</b> General purpose, oil-resistant. Shows good solvent, oil, water and hydraulic fluid resistance. Should not be used with highly polar solvents like acetone and MEK, ozone, chlorinated hydrocarbons and nitro hydrocarbons.	190°F 88°C	-10°F -23°C
<b>EPDM</b> Shows very good water and chemical resistance. Has poor resistance to oil and solvents, but is fair in ketones and alcohols.	280°F 138°C	-40°F -40°C
<b>NEOPRENE</b> All purpose. Resistant to vegetable oils. Generally not affected by moderate chemicals, fats, greases and many oils and solvents. Generally attacked by strong oxidizing acids, ketones, esters, nitro hydrocarbons and chlorinated aromatic hydrocarbons.	200°F 93°C	-10°F -23°C
<b>HYTREL®</b> Good on acids, bases, amines and glycols at room temperature.	220°F 104°C	-20°F -29°C
<b>FKM (Fluorocarbon)</b> shows good resistance to a wide range of oils and solvents; especially all aliphatic, aromatic and halogenated hydrocarbons, acids, animal and vegetable oils. Hot water or hot aqueous solutions (over 70°F) will attack FKM.	350°F 177°C	-40°F -40°C
<b>Urethane</b> Shows good resistance to abrasives. Has poor resistance to most solvents and oils.	150°F 66°C	+32°F 0°C
<b>Santoprene®</b> Injection molded thermoplastic elastomer with no fabric layer. Long mechanical flex life. Excellent abrasion resistance.	275°F 135°C	-40°F -40°C
‡ <b>CF-8M Stainless Steel</b> equal to or exceeding ASTM specification A743 for corrosion resistant iron chromium, iron chromium nickel, and nickel based alloy castings for general applications. Commonly referred to as 316 Stainless Steel in the pump industry.		

For specific applications, always consult "Chemical Resistance Chart" Technical Bulletin

This pump also available in dual port design.  
See price book or consult factory for details.

Dimensions are ± 1/8"  
Figures in parenthesis = millimeters

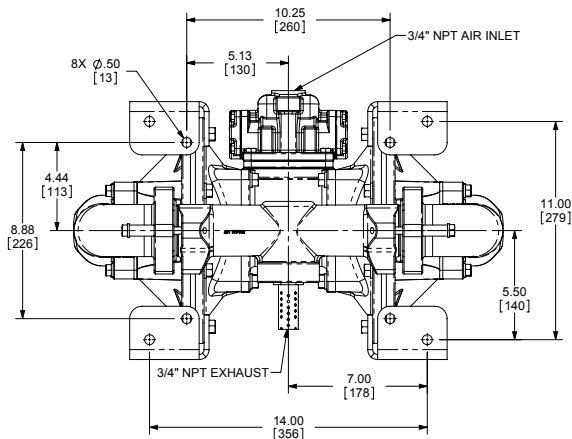
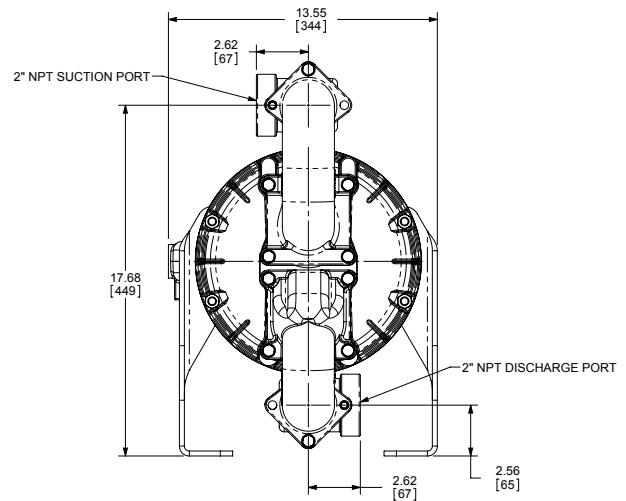
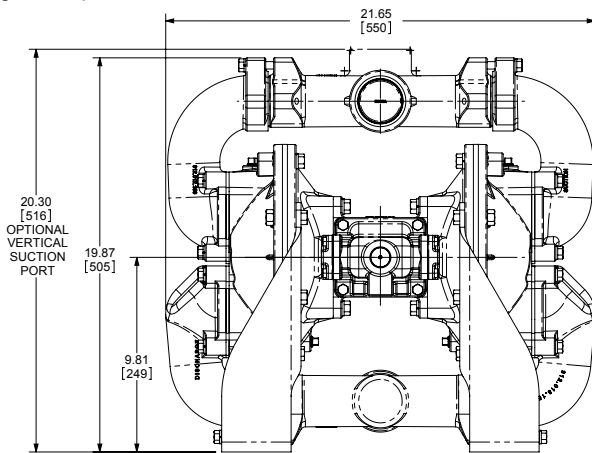

**2" NPT(F) Suction and Discharge • 3/4" NPT(F) Air Inlet  
Port • 3/4" NPT(F) Air Exhaust Port (not shown)**



# Declaration of Conformity

**Manufacturer:**

**Warren Rupp, Inc.®, 800 N. Main Street, P.O. Box 1568,  
Mansfield, Ohio, 44901-1568 USA**

certifies that Air-Operated Double Diaphragm Pump Series:  
M Non-Metallic, M Metallic, and Surge Suppressors comply  
with the European Community Directive 2006/42/EC on Machinery,  
according to Annex VIII. This product has used Harmonized Standard  
EN 809, Pumps and Pump Units for Liquids - Common Safety  
Requirements, to verify conformance.

David Roseberry  
Signature of authorized person

October 20, 2005  
Date of issue

David Roseberry  
Printed name of authorized person

Engineering Manager  
Title

Revision Level: E

May 27, 2010  
Date of revision



Declaration of Conformity

Declaration of Conformity



# EC Declaration of Conformity

In accordance with ATEX Directive 94/9/EC,  
Equipment intended for use in potentially explosive environments.

**Manufacturer:**

Warren Rupp, Inc.®  
A Unit of IDEX Corporation  
800 North Main Street  
P.O. Box 1568  
Mansfield, OH 44901-1568 USA

**Applicable Standard:**

EN13463-1: 2001,  
EN13463-5: 2003



**EN 60079-25: 2004**

For pumps equipped with Pulse Output ATEX Option  
KEMA Quality B.V. (0344)

**AODD Pumps and Surge Sppressors**

For Type Examination Designations, see page 2 (back)

**AODD (Air-Operated Double Diaphragm) Pumps**

EC Type Examination Certificate No. Pumps: KEMA 09ATEX0071 X

KEMA Quality B.V.  
Utrechtseweg 310  
6812 AR Arnhem, The Netherlands

DATE/APPROVAL/TITLE:  
27 MAY 2010

  
David Roseberry, Engineering Manager



## EC Declaration of Conformity

### ATEX Summary of Markings

Type	Marking	Listed In	Non-Conductive Fluids	
Pump types, M05, M1F, M15, M20 and M30 provided with the pulse output option	II 2 G Ex ia c IIC T5 II 3/2 G Ex ia c IIC T5 II 2 D Ex c iaD 20 IP67 T100°C	KEMA 09ATEX0071 X CE 0344	KEMA 09ATEX0071 X KEMA 09ATEX0071 X KEMA 09ATEX0071 X	No Yes Yes
Pump types, M05, M1F, M15 M20 and M30 provided with the integral solenoid option	II 2 G EEx m c II T5 II 3/2 G EEx m c II T5 II 2 D c IP65 T100°C	KEMA 09ATEX0071 X CE 0344	KEMA 09ATEX0071 X KEMA 09ATEX0071 X KEMA 09ATEX0071 X	No Yes Yes
Pump types, MPB1/4, M05, M1F, M15, M20, M30, MSB1, MHDF1, MHDF2 without the above listed options, no aluminum parts	II 1 G c T5 II 3/1 G c T5 II 1 D c T100°C I M1 c I M2 c	KEMA 09ATEX0071 X KEMA 09ATEX0072 X CE 0344	KEMA 09ATEX0071 X KEMA 09ATEX0071 X KEMA 09ATEX0071 X KEMA 09ATEX0071 X KEMA 09ATEX0072 X	No Yes Yes No Yes
Pump types, MPB1/4, M05, M1F, M15, M20, M30, MSB1, MHDF1, MHDF2, MHDF3	II 2 G c T5 II 3/2 G c T5 II 2 D c T100°C	KEMA 09ATEX0072 X CE	KEMA 09ATEX0072 X KEMA 09ATEX0072 X KEMA 09ATEX0072 X	No Yes Yes
MT Series Surge Suppressors	II 2 G T5 II 3/2 G T5 II 2 D T100°C	KEMA 09ATEX0073 CE	KEMA 09ATEX0073 KEMA 09ATEX0073 KEMA 09ATEX0073	No Yes Yes

EC Type Certificate No. Pumps: KEMA 09ATEX0071 X  
 Type Certificate No. Pumps: KEMA 09ATEX0072 X  
 Type Certificate No. Suppressors: KEMA 09ATEX0073